

# Refrigerator

## use & care

Introduction.....	2	Automatic Ice and Water Dispenser.....	19
Important Safety information.....	3	Storage Features.....	21
Features .....	6	Normal Operating Sounds.....	22
Installation .....	7	Filter Replacement .....	23
Door Removal .....	10	Care and Cleaning .....	25
Door Handle Installation.....	12	Troubleshooting .....	29
Water Supply Connection.....	13	Limited Warranty .....	33
Controls and Settings .....	15		

# 2

## INTRODUCTION

Welcome to our **family**

Thank you for bringing Frigidaire into your home! We see your purchase as the beginning of a long relationship together.

This manual is your resource for the use and care of your product. Please read it before using your appliance. Keep it handy for quick reference. If something doesn't seem right, the troubleshooting section will help you with common issues.

FAQs, helpful tips and videos, cleaning products, and kitchen and home accessories are available at Frigidaire.com.

We are here for you! Visit our website, chat with an agent, or call us if you need help. We may be able to help you avoid a service visit. If you do need service, we can get that started for you.

Let's make it official! Be sure to register your product.

Keep your product info here so it's easy to find.

Model Number \_\_\_\_\_  
Serial Number \_\_\_\_\_  
Purchase Date \_\_\_\_\_

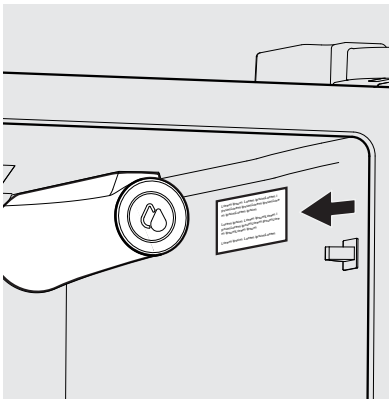

Serial Number Location



### Installation Checklist

#### Doors

- Handles are secure and tight
- Door seals completely to cabinet on all sides
- Doors are level with each other.

#### Leveling

- Appliance is level side-to-side and tilted 1/4" (6 mm) front-to-back
- Toe grille is properly attached.
- Cabinet is level on the floor.

#### Electrical Power

- House power turned on
- Appliance is plugged in

#### Ice Maker

- House water supply connected to appliance (**Warning:** Potable water supply only.)
- No water leaks present at all connections - recheck in 24 hours
- Ice maker is turned ON
- Ice and water dispenser operates correctly

#### Final Checks

- Shipping material removed
- Refrigerator and freezer temperatures set to recommended setting
- Crisper humidity controls set (some models)
- Registration card sent in



## WARNING

Please read all instructions before using this appliance.

### Safety Definitions

 This is the safety alert symbol. It is used to alert of potential personal injury hazards. Obey all safety messages that follow this symbol to avoid possible injury or death.



## DANGER

DANGER indicates an imminently hazardous situation which, if not avoided, will result in death or serious injury.



## WARNING

WARNING indicates a potentially hazardous situation which, if not avoided, could result in death or serious injury.



## CAUTION

CAUTION indicates a potentially hazardous situation which, if not avoided, may result in minor or moderate injury.



## IMPORTANT

IMPORTANT indicates installation, operation or maintenance information which is important but not hazard-related.



## DANGER



DANGER Risk of fire or explosion. Flammable refrigerant used. Do not use mechanical devices to defrost refrigerator. Do not puncture refrigerant tubing.

DANGER Risk of fire or explosion. Flammable refrigerant used. To be repaired only by trained service personnel. Use only manufacturer-authorized service parts. Any repair equipment used must be designed for flammable refrigerants. Follow all manufacturer repair instructions. Do not puncture refrigerant tubing.



## CAUTION



CAUTION Risk of fire or explosion. Dispose of refrigerator properly in accordance with the applicable federal or local regulations. Flammable refrigerant used.

CAUTION Risk of fire or explosion due to puncture of refrigerant tubing. Follow handling instructions carefully. Flammable refrigerant used.



## WARNING

**CALIFORNIA RESIDENTS ONLY**  
**Cancer and Reproductive Harm**  
[www.P65Warnings.ca.gov](http://www.P65Warnings.ca.gov)

# 4

## IMPORTANT SAFETY INFORMATION

### Child Safety

This appliance is not intended for use by persons (including children) with reduced physical, sensory or mental capabilities, or lack of experience and knowledge, unless they have been given supervision or instruction concerning use of the appliance by a person responsible for their safety.

Destroy or recycle the carton, plastic bags, and any exterior wrapping material immediately after the appliance is unpacked. Children should **NEVER** use these items to play. Cartons covered with rugs, bedspreads, plastic sheets or stretch wrap may become airtight chambers, and can quickly cause suffocation.

### Safety Instructions

- DO NOT store or use gasoline, or other flammable liquids, or aerosols within or in the vicinity of this or any other appliance. Read product labels for warnings regarding flammability and other hazards.
- DO NOT operate the unit in the presence of explosive fumes.
- Avoid contact with any moving parts of automatic ice maker.
- Remove all staples from the carton. Staples can cause severe cuts, and also destroy finishes if they come in contact with other appliances or furniture.



#### WARNING

Do not use electrical appliances inside the food storage compartments of the appliance unless they are of the type recommended by the manufacturer.

### Proper Disposal of your Appliance

#### Risk of child entrapment

Child entrapment and suffocation are not problems of the past. Junked or abandoned appliances are still dangerous – even if they will sit for “just a few days”. If you are getting rid of your old unit, please follow the instructions below to help prevent accidents.

We strongly encourage responsible appliance recycling/disposal methods. Check with your utility company or visit [energystar.gov/recycle](http://energystar.gov/recycle) for more information on recycling your old appliance.

#### Before you throw away your appliance:

- Remove doors.
- Leave shelves in place so children may not easily climb inside.
- Have refrigerant removed by a qualified service technician.

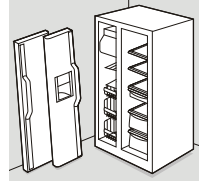

#### WARNING

These guidelines must be followed to ensure that safety mechanisms in this unit will operate properly.

## Electrical information

- **The appliance must be plugged into its own dedicated 115 Volt, 60 Hz., 15 Amp, AC only electrical outlet.** The power cord of the appliance is equipped with a three-prong grounding plug for your protection against electrical shock hazards. It must be plugged directly into a properly grounded 3-prong receptacle. The receptacle must be installed in accordance with local codes and ordinances. Consult a qualified electrician. Avoid connecting the unit to a Ground Fault Interrupter (GFI) circuit. **Do not use an extension cord or adapter plug.**
- If the power cord is damaged, it should be replaced by an authorized service technician to prevent any risk.
- Never unplug the appliance by pulling on the power cord. Always grip the plug firmly, and pull straight out from the receptacle to prevent damaging the power cord.
- Performance may be affected if the voltage varies by 10% or more. Operating the appliance with insufficient power can damage the compressor. Such damage is not covered under your warranty.
- Do not plug the unit into an electrical outlet controlled by a wall switch or pull cord to prevent the unit from being turned off accidentally.



## IMPORTANT

Turn off power to your appliance you must unplug the power cord from the electrical outlet.

Grounding type wall receptacle

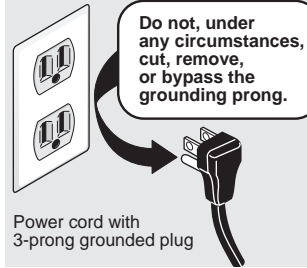

## CAUTION

To avoid personal injury or property damage, handle tempered glass shelves carefully. Shelves may break suddenly if nicked, scratched, or exposed to sudden temperature change.



## IMPORTANT

### CFC/HCFC Disposal

Your old unit may have a cooling system that used CFCs or HCFCs (chlorofluorocarbons or hydrochlorofluorocarbons). CFCs and HCFCs are believed to harm stratospheric ozone if released to the atmosphere. Other refrigerants may also cause harm to the environment if released to the atmosphere.

If you are throwing away your old appliance, make sure the refrigerant is removed for proper disposal by a qualified technician. If you intentionally release refrigerant, you may be subject to fines and imprisonment under provisions of environmental legislation.

# 6

## FEATURES

\*Features may vary according to model

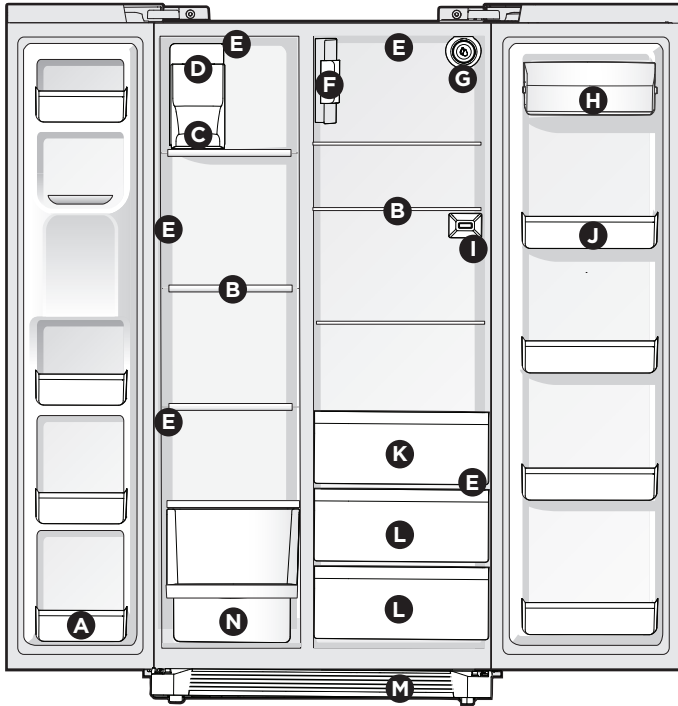

<b>A</b>	Fixed Door Bins
<b>B</b>	Shelves
<b>C</b>	Ice Container
<b>D</b>	Ice Maker
<b>E</b>	LED Lights (some models)
<b>F</b>	Damper/Air filter housing
<b>G</b>	Water Filter

<b>H</b>	Dairy Compartment
<b>I</b>	Temperature Sensor/Thermistor
<b>J</b>	Adjustable Door Bins
<b>K</b>	Deli Drawer (some models)
<b>L</b>	Crisper Pan
<b>M</b>	Toe Grille
<b>N</b>	Slide Out Basket



### IMPORTANT

Accessories are available for your appliance and may be purchased at [Frigidaire.com](http://Frigidaire.com) or by calling 1-800-374-4432 (Frigidaire.ca or 1-800-265-8352 in Canada) or from an authorized seller.

This Use & Care Manual provides general operating instructions for your model. Use the unit only as instructed in this Use & Care Manual. **Before starting the appliance, follow these important first steps.**

## Location

- Choose a place that is near a grounded electrical outlet. **Do Not** use an extension cord or an adapter plug.
- If possible, place the unit out of direct sunlight and away from the range, dishwasher or other heat sources.
- Install the appliance on a floor that is level and strong enough to support a fully loaded unit.
- Consider water supply availability for models equipped with an automatic ice maker. If you do not hook up water to the appliance, remember to turn the ice maker off.



## WARNING

This appliance is intended for use in residential household and similar interior applications such as:

- a kitchen/kitchenette
- a pantry room
- a basement
- an enclosed garage
- other interior residential-type environments



## CAUTION

**Do Not** install the unit where the temperature will drop below 55°F (13°C) or rise above 110°F (43°C). The compressor will not be able to maintain proper temperatures inside the appliance.

**Do Not** block the toe grille on the lower front of your unit. Sufficient air circulation is essential for the proper operation of your appliance.

## Installation

### Installation clearances

Allow the following clearances for ease of installation, proper air circulation, and plumbing and electrical connections:

Sides & Top	3/8"
Back	1"



## NOTE

If your unit is placed with the door hinge side against a wall, you may have to allow additional space for the handle so the door can be opened wider.

## Toe Grille Installation and Removal

### To install toe grille

1. Open both doors. Slide the left and right sides of the toe grille over the lower hinges of the appliance.
2. While pushing the toe grille firmly against cabinet, fasten the bottom clips of toe grille to the cabinet.
3. Fasten the top clips to the cabinet.
4. Close the doors. Fasten the right and left side clips into the groove of the bottom hinge.

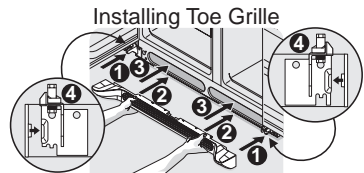

### To remove the toe grille

1. With both doors closed, unfasten the right and left side clips of toe grille from the bottom hinge groove.
2. Open both doors. Press firmly on the top of the toe grille until the top of the toe grille pops off.
3. Pull the toe grille outward toward your body and off of the lower hinges.



## Door Opening



## NOTE

The doors are designed to shut by themselves within a 20 degree opening.

Position your unit to allow easy access to a counter or table when removing food. For the best use of drawers and freezer baskets, position the appliance where both doors can fully open.

# 8

## INSTALLATION

### Guidelines for final positioning of your unit:

- Rest all 4 corners of the cabinet firmly on the floor.
- Level the cabinet at the front and rear so the front is raised  $\frac{1}{4}$ " (6 mm) above the rear to ensure the door will open/close and seal properly.
- Align the doors with each other and level.

### Meet all of these conditions by raising or lowering the adjustable leveling feet.

#### To level the cabinet using the leveling feet:

1. Open both doors and remove the toe grille (see **Toe Grille Installation and Removal** in the **INSTALLATION** section).
2. Level the cabinet at the front and rear so the front is raised  $\frac{1}{4}$  in. (6 mm) above the rear. Close the doors and use a wrench to raise (clockwise) or lower (counterclockwise) the front leveling feet.

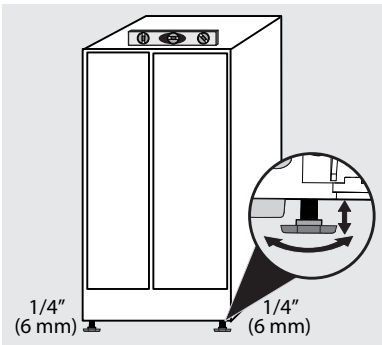

3. Ensure both doors are bind free with their seals touching the cabinet on all 4 sides.

### To level the doors using the adjustable lower hinge:

1. Before leveling either door, remove the set screw that locks the door height into position using a  $\frac{3}{32}$ " hex key.

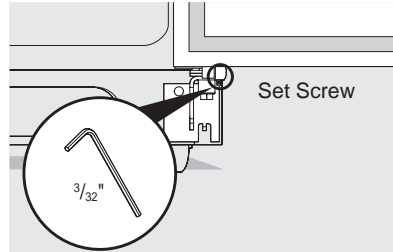

2. If the freezer door is lower than the refrigerator door (A) or the refrigerator door is lower than the freezer door (B), raise the door by turning the adjustment screw counterclockwise using a 12 mm wrench.

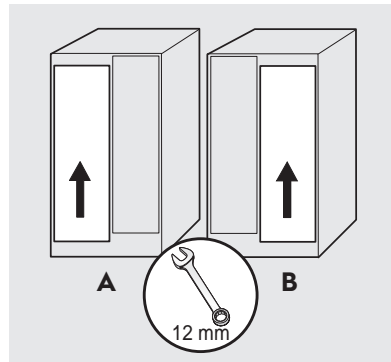



3. After leveling, verify the door stop contacts the lower hinge and the top of the door does not contact the upper hinge through full movement of the door (from fully closed to fully open).

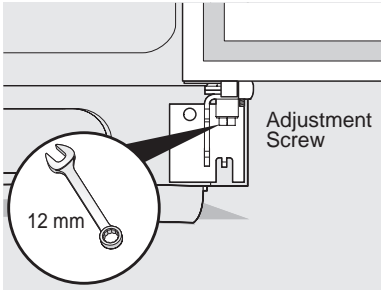

4. Reinstall the set screw, locking the door height.
5. Replace the toe grille by fitting it into place (see **Toe Grille Installation and Removal** in the **INSTALLATION** section).

# 10 DOOR REMOVAL

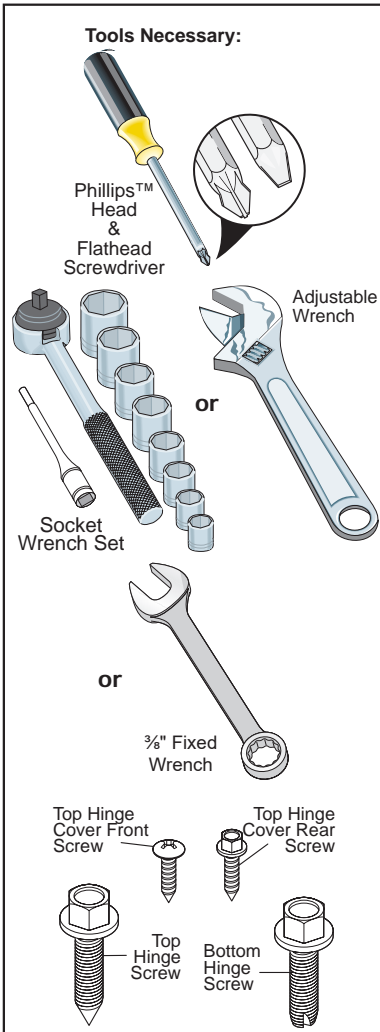

## To remove the refrigerator top hinge/cover:

1. Remove the 2 screws from the cover over the top door hinge.
2. Lift hinge cover straight up and off.
3. Trace lightly around the door's top hinge with a pencil. This makes reinstallation easier.
4. Remove the 2 screws from the top hinge and lift the hinge straight up. Lift the door off of the bottom hinge and set it aside.
5. Remove the 2 bottom hinge screws and hinge if necessary.

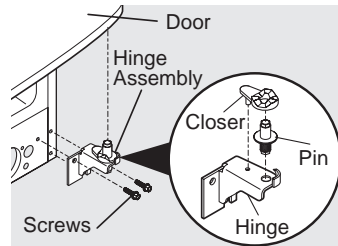
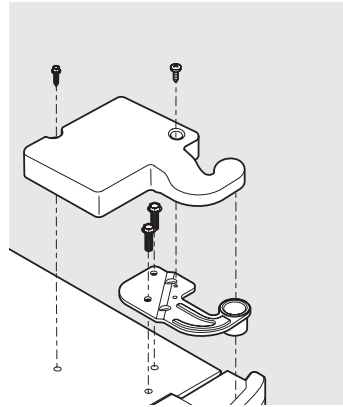

Adjustable Hinge

## To prepare for removing the doors:

1. Make sure the electrical power cord is unplugged from the wall outlet.
2. Open both doors and remove the toe grille (as explained in the Installation Instructions that came with your appliance).
3. Remove any food from the door shelves.
4. Close the doors.

To reinstall the refrigerator door, reverse the above steps.

### To remove the freezer top hinge cover:

1. Remove the 2 screws from the cover over the top door hinge.
2. Lift hinge cover straight up and off.

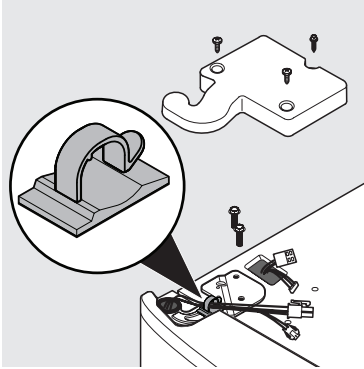

### To remove the freezer door:

1. Release the wires from the routing clip. **NOTE:** To prevent wire damage, ensure the wires are rerouted through the routing clip when reassembling the hinge cover.
2. Disconnect the 2 multi-wire cable connectors located above the top hinge. Grasp both sides of the connector firmly, press the connector lock and pull apart. Remove the ground screw.

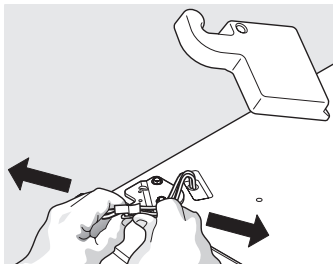

3. Trace lightly around the hinge with a pencil. This makes reinstallation easier.
4. Detach the water tube from the connector located below the freezer door. The connector releases when you press its outer sleeve inward.

### To Disconnect

1. Press outer ring against face of fitting
2. Pull to remove tube

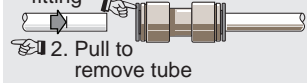

### To Connect

1. Insert tube and push until mark touches face of fitting

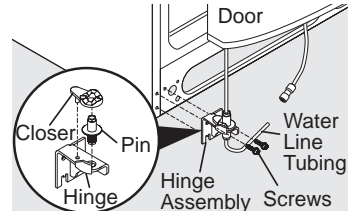
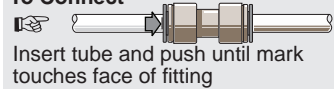

### Adjustable Hinge (some models)

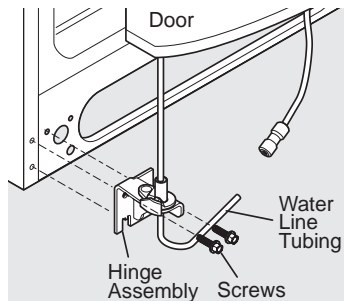

### Non-Adjusting Hinge (some models)

5. Remove the 2 screws from the top hinge and lift the hinge straight up, pulling the 2 multi-wire cables through it. Lift the door off of the bottom hinge.
6. Remove the 2 bottom hinge screws and hinge if necessary.
7. Lay the door on its side to avoid damage to the water tube extending from the bottom hinge.

To reinstall the freezer door, reverse the above steps.

### **!** CAUTION

Be sure doors are set aside in a secure position where they cannot fall and cause personal injury.

# 12

## DOOR HANDLE INSTALLATION



### CAUTION

Wear gloves and safety goggles and use extreme CAUTION when installing these handles. The rounded end of the handles may be sharp (some models).



### IMPORTANT

To ensure proper installation of handles, please review these instructions and illustrations thoroughly prior to installing the handles.

1. Remove handles from carton and any other protective packaging.
2. Position the freezer handle end caps over the upper and lower pre-installed shoulder bolts (A) that are fastened into door, ensuring the holes for the set screws are facing toward the refrigerator door.
3. While holding the handle firmly against door, fasten the upper and lower Allen set screws (B) with the supplied Allen wrench.
4. Repeat steps 2 and 3 to install refrigerator handle. Ensure the holes for the set screws are facing towards the freezer door.



### NOTE

Tighten and sub-flush all set screws (place the Allen set screw just below the surface of the end cap) of the handle end cap. Draw the end caps tight to the freezer and refrigerator doors with no gaps. To avoid scratching the metal door, keep the door open while torquing down the set screws.

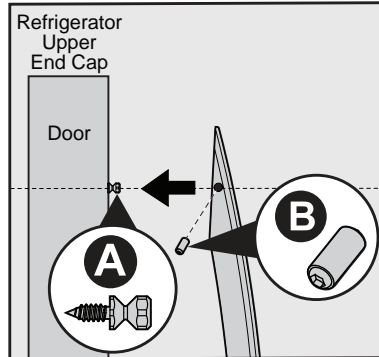
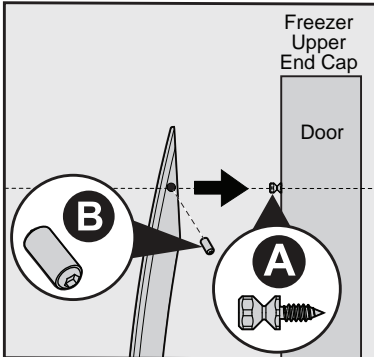

Ensure Handle Set Screws are Facing Each Other with Doors Closed

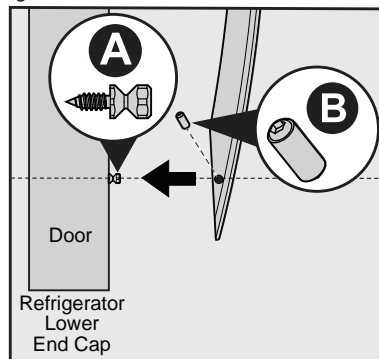
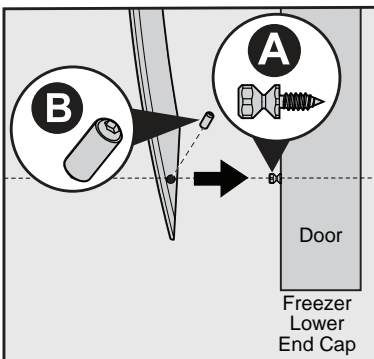



## WARNING

To avoid electric shock, which can cause death or severe personal injury, disconnect the unit from electrical power source before connecting a water supply line to the appliance.



## CAUTION

To Avoid Property Damage:

- Use Copper or Stainless Steel braided tubing for the water supply line. Frigidaire does not recommend water supply tubing made of ¼" plastic. Plastic tubing greatly increases the potential for water leaks, and the manufacturer will not be responsible for any damage if plastic tubing is used for the supply line.
- DO NOT install water supply tubing in areas where temperatures fall below freezing.
- Chemicals from a malfunctioning softener can damage the ice maker. If the ice maker is connected to soft water, ensure that the softener is maintained and working properly.



## IMPORTANT

Ensure that your water supply line connections comply with all local plumbing codes.

### Before Installing The Water Supply Line, You Will Need:

- Basic Tools: adjustable wrench, flat-blade screwdriver, and Phillips™ screwdriver
- Access to a household cold water line with water pressure between 30 and 100 psi.
- A water supply line made of ¼" (6.4 mm) OD, copper or stainless steel tubing. To determine the length of tubing needed, measure the distance from the ice maker inlet valve at the back of the refrigerator to your cold water pipe. Then add approximately 7' (2.1 m), so the refrigerator can be moved out for cleaning.

- A shutoff valve to connect the water supply line to your household water system. DO NOT use a self-piercing type shutoff valve.
- Do not reuse compression fitting or use thread seal tape.
- A compression nut and ferrule (sleeve) for connecting a copper water supply line to the ice maker inlet valve.



## NOTE

Check with your local building authority for recommendations on water lines and associated materials prior to installing your new refrigerator. Depending on your local/state building codes, Frigidaire recommends for homes with existing valves its **Smart Choice**™ water line kit 5304490728 (with a 6' Stainless Steel Water Line) and for homes without an existing valve, Frigidaire recommends its **Smart Choice**™ water line kit 5304490717 (with a 20' copper water line with self-tapping saddle valve). Please refer to Frigidaire.com for more information.

### To Connect Water Supply Line To Ice Maker Inlet Valve

1. Disconnect the refrigerator from electrical power source.
2. Place the end of the water supply line into a sink or bucket. Turn ON the water supply and flush the supply line until the water is clear. Turn OFF the water supply at the shutoff valve.
3. Remove the plastic cap from the water valve inlet and discard the cap.
4. **If you use copper tubing** - Slide the brass compression nut, and then the ferrule (sleeve) onto the water supply line. Push the water supply line into the water valve inlet as far as it will go (¼"/6.4 mm). Slide the ferrule (sleeve) into the valve inlet and finger tighten the compression nut onto the valve. Tighten another half turn with a wrench; DO NOT overtighten. See Figure 1.

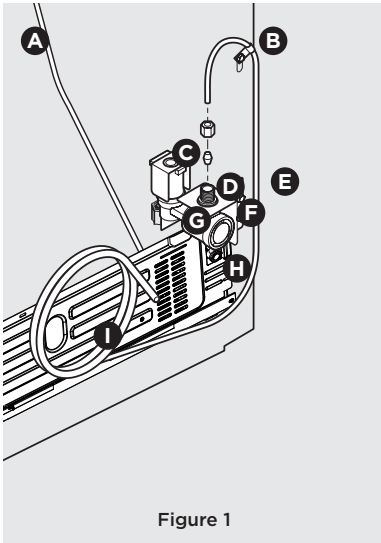

Figure 1

**If you use braided flexible stainless steel tubing** - The nut is already assembled on the tubing. Slide the nut onto the valve inlet and finger tighten the nut onto valve. Tighten another half turn with a wrench; DO NOT overtighten. See Figure 2.

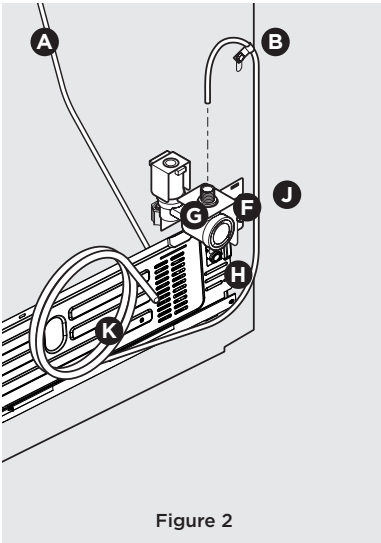

Figure 2

A	Plastic Water Tubing to Ice Maker Fill Tube
B	Steel Clamp
C	Brass Compression Nut
D	Ferrule (Sleeve)
E	Copper Water Line
F	Water Valve Bracket
G	Valve Inlet
H	Water Valve
I	Copper Water Line from Household Water Supply*
J	Braided Flexible Stainless Steel Water Line
K	6 ft. (1.8 m) Braided Flexible Stainless Steel Water Line from Household Water Supply*

\*Include enough tubing in the loop to allow moving the refrigerator out for cleaning

- With the steel clamp and screw, secure the water supply line (copper tubing only) to the rear panel of refrigerator as shown.
- Coil the excess water supply line (copper tubing only), about 2½ turns, behind refrigerator as shown and arrange coils so they do not vibrate or wear against any other surface.
- Turn ON the water supply at shutoff valve and tighten any connections that leak.
- Reconnect the refrigerator to electrical power source.



### IMPORTANT

After connecting the water supply, refer to **Priming the Water Supply System** for important information about priming an empty water supply system.

Your refrigerator's water supply system includes several tubing lines, a water filter, and a water valve. To ensure that your water dispenser works properly, completely fill this system with water when you first connect your refrigerator to the household water supply line.

## NOTE

Your appliance may have some or all of the features listed below. Become familiar with these features and their use and care.

### Front of Door User Interface



**Cube** Press the **Cube** button to get cubed ice. A white LED light will indicate the mode is selected. Press glass against the ice dispensing paddle as far up as possible to catch all the ice.

**Crush** Press the **Crush** button to get crushed ice. A white LED light will indicate the mode is selected. Press glass against the ice dispensing paddle as far up as possible to catch all the ice.

**Light** Press the light button  to turn on the dispenser light. A white LED light will indicate the dispenser light is on. Press again to turn the light off.

**Ice Maker** Press and hold the **Ice Maker** button for 3 seconds to turn on the ice maker. To turn the ice maker off, press and hold the **Ice Maker** button again for 3 seconds. When the **Ice Maker** LED is on, the ice maker is on. When the LED is off, the ice maker is off.

**Water** To operate the water dispenser, press a glass against the **Water** dispensing paddle. To stop dispensing water, pull the glass away from the dispensing paddle. Dispensed water is not cold. For colder water, add crushed ice or cubes before dispensing water.

**Water Filter Status** When you need to order a new water filter, the side door UI will change to the Order status. When you need to replace the water filter, the Side Door UI will change to the red replace status and the front UI will display **Replace Water Filter**. After you change the filter, hold the **Water Filter** button for 3 seconds to reset.

**Air Filter Status\*** When you need to order a new air filter, the Side Door UI will change to the Order status. When you need to replace the air filter, the Side Door UI will change to the red Replace status and the Front UI will display **Replace Air Filter**. After you change the filter, hold the **Air Filter** button for 3 seconds to reset.

**\*Only on some models**

# 16

## CONTROLS AND SETTINGS

---

### Alarms

**Power Outage** In the event of a power outage the Power Outage indicator appear and an alarm will sound. Press any button to clear the alarm.

**Door Open** When a door is open the **Door Open** indicator will appear and will disappear when the door is closed. If a door is left open for more than 5 minutes an alarm will sound. The alarm will continue to go off every 10 seconds until acknowledged. Close the door to turn off the alarm or press any button on the control to temporarily disable the alarm.

**High Temp** In the event of the internal temperature of the refrigerator rising and staying at a temperature above the safe temp zone for a period of time, the **High Temp** warning will appear to remind you to check your food. In addition to the indicator, an alarm will sound every 10 seconds until acknowledged. Press any button to clear the warning.

The refrigerator will automatically try to cool down to improve the condition. However, if the temperature has not cooled after some time, the warning and alarm will appear again. If the problem continues please call 1 (800) 372-4432.

---



## In-Door User Interface

Active Mode View

The Active Mode View displays four control panels. Each panel features a vertical slider with 'Cold' at the top and 'Coldest' at the bottom, and a 'Recommended' mark with a left-pointing arrow. Below each slider is a button labeled 'Freezer Temp', 'Refrigerator Temp', 'Air Filter', and 'Water Filter' respectively. Under the 'Air Filter' and 'Water Filter' buttons, there are three horizontal bar indicators labeled 'Good', 'Order', and 'Replace'. The 'Air Filter' and 'Water Filter' buttons also include the text 'Hold to Reset' below them.

Inactive Mode View

The Inactive Mode View displays four control panels, identical in layout to the Active Mode View. Each panel features a vertical slider with 'Cold' at the top and 'Coldest' at the bottom, and a 'Recommended' mark with a left-pointing arrow. Below each slider is a button labeled 'Freezer Temp', 'Refrigerator Temp', 'Air Filter', and 'Water Filter' respectively. Under the 'Air Filter' and 'Water Filter' buttons, there are three horizontal bar indicators labeled 'Good', 'Order', and 'Replace'. The 'Air Filter' and 'Water Filter' buttons also include the text 'Hold to Reset' below them.

Sleep Mode View

The Sleep Mode View displays four control panels, identical in layout to the Active Mode View. Each panel features a vertical slider with 'Cold' at the top and 'Coldest' at the bottom, and a 'Recommended' mark with a left-pointing arrow. Below each slider is a button labeled 'Freezer Temp', 'Refrigerator Temp', 'Air Filter', and 'Water Filter' respectively. Under the 'Air Filter' and 'Water Filter' buttons, there are three horizontal bar indicators labeled 'Good', 'Order', and 'Replace'. The 'Air Filter' and 'Water Filter' buttons also include the text 'Hold to Reset' below them.

### In-Door Control Display Mode Views

Your display is equipped with a sleep and inactive mode to prevent accidental changes to the unit settings during opening and closing of the doors. When both doors are closed, the display will be in sleep mode. When either door is first opened, the display will be in inactive mode where all the current settings are visible but dimmed.

Pressing any button on the display will activate the display and a tone will be played. All settings will then be fully lit. Touch the display again to change any setting.

If there is no button pressed for 10 seconds while any door is open, the display will default back to inactive mode.

**Temperature Adjustment** Adjust the temperature gradually: adjust in small increments, allowing the temperature to stabilize.

- For colder temperatures, press the **Temp** button to change the temperature setting toward **Coldest**.
- For warmer temperatures, press the **Temp** button to change the temperature setting toward **Cold**.

Adjusting the refrigerator control will change temperature in both compartments. The freezer control can be left at the factory preset (\*Recommended) or adjusted as desired.

To maintain temperatures, a fan circulates air in the refrigerator and freezer compartments. For good circulation, do not block cold air vents with food items.

**Air Filter Status\*** The display shows the current status of the air filter (**Good**, **Order**, or **Replace**). To reset the filter status to **Good**, press and hold **Air Filter** for 3 seconds.

**Water Filter Status** The displays shows the current status of the water filter (**Good**, **Order**, or **Replace**). To reset the filter status to **Good**, press and hold **Water Filter** for 3 seconds.

**\*Only on some models**

## Priming the water supply system



### CAUTION

For proper dispenser operation, the recommended water supply pressure should fall between 30 psi and 100 psi. Excessive pressure may cause the system to malfunction.

1. Begin filling the system by pressing and holding a drinking glass against the water dispenser paddle.
2. Keep the glass in this position until water comes out of the dispenser. It may take about 1½ minutes. Water will sputter until you purge all air from the water lines.
3. Continue dispensing water for about 4 minutes to flush the system and plumbing connections of any impurities (stopping to empty the glass as necessary).



Dispenser  
(varies by model)



### NOTE

Dispensed water is not chilled. For colder water, add ice to cup or container before dispensing water.

## Ice maker operation & care

After you properly install the refrigerator and it has cooled for several hours, the ice maker can produce ice within 24 hours. The ice maker will fill the ice bin from the rear. You must dispense some ice to force the ice forward in the bin. This will allow the bin to fill completely.

## Turning the ice maker on

Ice production is controlled by the ice maker's on/off feature on the control panel. Press and hold the **Ice Maker** button for 3 seconds to turn the ice maker on/off.

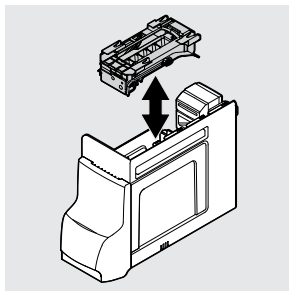

### IMPORTANT

Turning off the ice maker simply disables ice making. You will still be able to dispense existing ice, and you will still be able to dispense water.



### NOTE

The ice maker also has a built-in plastic signal arm that automatically stops ice production when the ice bin is full. Do not use this signal arm to manually stop the ice maker.



### NOTE

The water dispenser has a built-in device that shuts off the water flow after 3 minutes of continuous use. To reset this shutoff device, simply release the dispenser paddle.

### Ice Maker/Dispenser Tips

- Ice cubes stored too long may develop an odd flavor. Empty the ice container as explained in **Cleaning the Ice Storage Bin**.
- Occasionally shake the ice container to keep ice separated.
- If your refrigerator is not connected to a water supply or the water supply is turned off, turn **Off** the ice maker.
- If you need a large quantity of ice at one time, it is best to get cubes directly from the ice container.
- The following sounds are normal when the ice maker is operating:
  - Motor running
  - Ice dropping into ice container
  - Water valve opening or closing
  - Ice loosening from tray
  - Running water
- When dispensing ice, you will hear a snapping or clicking sound when the ice chute opens and closes.
- Turn **Off** the ice maker when cleaning the freezer and during vacations. If you turn **Off** the ice maker for a long period of time, you should also turn off the water supply valve.



#### CAUTION

Chemicals from a malfunctioning water softener can damage the ice maker. If the water supply to your refrigerator is softened, be sure the softener is maintained to work properly.

### Cleaning the Ice Storage Bin

Clean the ice storage bin at regular intervals, particularly before you take a vacation or move.

#### To clean the ice storage bin:

1. Turn **Off** the ice maker.
2. Remove the ice storage bin by lifting up and out.
3. Empty and carefully clean the ice storage bin with mild detergent. Rinse with clear water. Do not use harsh or abrasive cleaners.
4. Allow the ice storage bin to dry completely before replacing it in the freezer.
5. Remove ice chips and clean the ice storage bin, shelf and the freezer door chute.
6. Replace the ice storage bin. Turn **On** the ice maker to resume ice production.

#### Remove and empty the ice storage bin if:

- An extended power failure (1 hour or longer) causes ice cubes in the ice storage bin to melt and freeze together, jamming the dispenser mechanism.
- You do not use the ice dispenser frequently. Ice cubes will freeze together in the bin, jamming the dispenser mechanism.

Remove the ice storage bin and shake to loosen the cubes or clean as explained above.



#### CAUTION

NEVER use an ice pick or similar sharp instrument to break up the ice. This could damage the ice storage bin and dispenser mechanism.



#### IMPORTANT

When removing or replacing the ice storage bin, avoid rotating the auger in the ice storage bin. If the auger is accidentally rotated, you must realign the auger by turning it in 45 degree turns (see below) until the ice storage bin fits into place with the drive mechanism. If the auger is not properly aligned when replacing the ice storage bin, the refrigerator will not dispense ice. The freezer door also may not close properly causing warm air to leak into the freezer compartment.

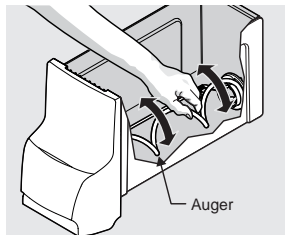

## Glass shelves

Shelves are easily adjusted to suit individual needs. Before adjusting the shelves, remove all food. Shelves are supported by side rails. See **Glass Shelves** in **CARE AND CLEANING** for proper shelf removal.

## Door storage

Door bins and shelves are provided for convenient storage of jars, bottles, and cans. You can quickly select frequently used items.

Some models have door bins that can accommodate gallon-sized plastic drink containers and economy-sized jars and containers. Some bins are adjustable for maximum storage capacity.

The dairy compartment, which is warmer than the general food storage section, is intended for short term storage of cheese, spreads, or butter.

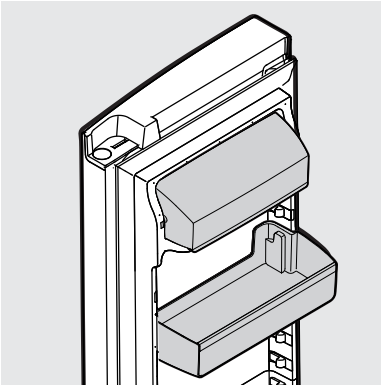

Dairy Bin and Door Bin

## Crispers

Crispers allow you the flexibility to store any manner of items including fruits, vegetables, nuts, etc. Crispers do not feature humidity controls.

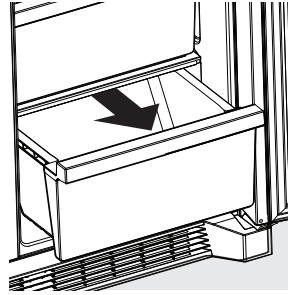

Crisper Drawer

## Deli Drawer (some models)

Some models are equipped with a Deli Drawer for storing luncheon meats, spreads, cheeses and other deli items. This drawer does not have a separate temperature control.

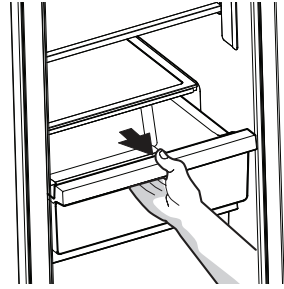

Deli Drawer

# 22

## NORMAL OPERATING SOUNDS

### Understanding the Sounds you may Hear

Your new, high-efficiency unit may introduce unfamiliar sounds. These sounds normally indicate your appliance is operating correctly. Some surfaces on floors, walls, and kitchen cabinets may make these sounds more noticeable.

Following is a list of major components in your unit and the *sounds* they can cause:

- A Evaporator** Refrigerant through the evaporator may create a *boiling* or *gurgling* sound.
- B Evaporator fan** You may hear *air being forced through the refrigerator* by the evaporator fan.
- C Defrost heater** During defrost cycles, water dripping onto the defrost heater may cause a *hissing* or *sizzling* sound. After defrosting, a *popping* sound may occur.
- D Condenser fan** You may hear *air being forced* through the condenser.
- E Water valve** Makes a *buzzing* sound each time it opens to fill the ice maker.
- F Drain pan** (not removable) You may hear *water dripping* into the drain pan during the defrost cycle.
- G Condenser** May create minimal sounds from *forced air*.
- H Motorized damper** May produce *intermittent humming* during operation.
- I Ice chute** When dispensing ice, you will hear a *snapping* or *clicking* sound when the solenoid opens and closes the ice chute.
- J Ice Maker** When ice has been produced, you will hear *ice cubes falling* into the ice bin.

### ★ Compressor

Today's refrigerators are designed with a variable speed compressor to be more energy efficient than previous models. This means your compressor reacts quickly to temperature fluctuations and circulates cold air based off your use and room temperature.

### 📌 NOTE

Energy efficient foam in your refrigerator is not a sound insulator.

### 📌 NOTE

During automatic defrost cycle, a red glow in the back wall vents of your freezer compartment is normal.

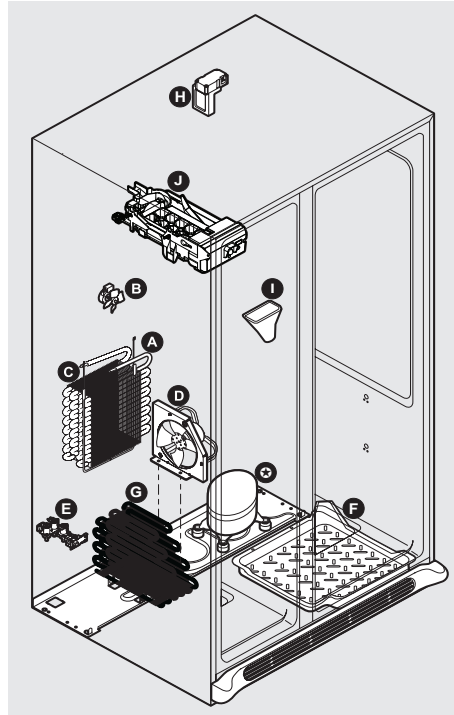

## PurePour™ Water Filter

Keep safe, great-tasting water flowing with a **PurePour** water filter. Using a **PurePour** water filter:

- **Makes Safe Water Second Nature**  
PurePour water filters are certified to reduce contaminants\* and keep great-tasting water flowing for you and your family.
- **Produces Purity You Can Trust**  
Know for certain your **PurePour** water filter is a protector. Counterfeits and knockoffs put your refrigerator and health at risk. Frigidaire Genuine Filters are the smarter, safer choice.
- **Every Drop Gives Back**  
Partnered on sustainability efforts, the use of a **PurePour** water filter helps cut back on the cost and use of plastic used to produce and package bottled water

\*For the complete list, please see Performance DataSheet on Frigidaire.com

## Replacing the Water Filter

The water filter is located at the top right side of the refrigerator compartment. In general, you should change the water filter

every 6 months to ensure the highest possible water quality. **Water Filter Status** on the user interface prompts you to replace the filter after a standard amount of water (125 gal/453 L for **PurePour**) has flowed through the system.

If you have not used your refrigerator for a period of time (during moving for example), change the filter before reinstalling the refrigerator.

## Ordering Replacement Filters

To order your replacement filters, please visit our online store at Frigidaire.com, by calling toll-free at 1 (800) 372-4432, or by visiting the dealer where you purchased your refrigerator. Frigidaire recommends that you order extra filters when you first install your refrigerator, and that you replace your filters at least once every 6 months.

Here are the product numbers to request when ordering:

**PurePour** Water Filter  
Part# **FPWFU01™**



### NOTE

When you order your replacement filter, please reorder the same filter type currently in your refrigerator.

## More about your Advanced Water Filter

**NSF** The **PurePour** ice and water filter system is tested and certified to NSF/ANSI Standards 42, 53, 401 and CSA B483.1 for the reduction of claims specified on the performance data sheet. Visit Frigidaire.com for more information.

Do not use with water that is microbiologically unsafe or of unknown quality without adequate disinfection before or after the system. Use systems certified for cyst reduction on disinfected waters that may contain filterable cysts.

### Test & certification results:

- Rated Capacity - 125 gal/453 L for **PurePour** and ice and water filter
- Rated service flow - .50 gal/min.
- Operating Temp.: Min. 33°F, Max. 100°F
- Maximum Rated Pressure - 100 lbs/in.<sup>2</sup>
- Recommended Minimum Operating Pressure: 30 lbs/in.<sup>2</sup>

### To replace your PurePour water filter:

It is not necessary to turn the water supply off to change the filter. Be ready to wipe up any small amounts of water released during the filter replacement.

1. Turn **Off** the ice maker.
2. Remove the filter by pushing on the end/face of the filter.
3. Slide the old water filter cartridge straight out of the housing and discard it.
4. Unpackage the new filter cartridge. Using the alignment guide, slide it gently into the filter housing until it stops against the snap-in connector at the back of the housing.
5. Push firmly until the cartridge snaps into place (you should hear a click as the cartridge engages the snap-in connector).
6. Press a drinking glass against the water dispenser while checking for any leaks at the filter housing. Any spurts and sputters that occur as the system purges air out of the dispenser system are normal.
7. After filling one glass of water, continue flushing the system for about **4 minutes**.
8. Turn **On** the ice maker.
9. Press and hold the **Water Filter** reset button on the Ice & Water Dispenser control panel for 3 seconds. When the display changes from red to green, the status has been reset.

# 24 FILTER REPLACEMENT

## PureAir Ultra II™ Air Filter (some models)

Some models are pre-loaded with an air filter located at the top of the fresh food compartment, next to the water filter.

### Replacing the Air Filter

You should change your air filter every 6 months (the filter status light on the control panel prompts you to replace the filter after 6 months) to optimize the reduction of refrigerator odors. Different foods will emit various levels of odor. To install your new **PAULTRA2 PureAir Ultra II** air filter:

1. Pull the air filter housing straight out.
2. Remove the old filter and discard it (if applicable).
3. Unpack the new filter and place it inside the housing.
4. Slide the housing back into position.
5. Activate or reset the **Air Filter** status light on the control panel.

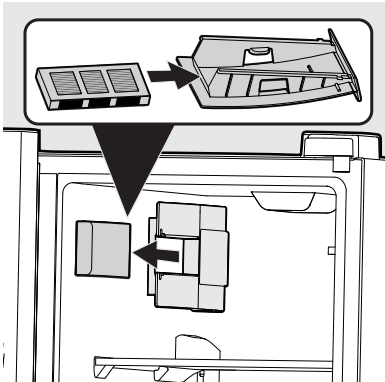

## Damper/Air Filter Housing

In humid regions certain products stored too close to the damper/air filter housing may freeze. If this scenario occurs, adjust the fresh food temperature settings and reconfigure the top shelf storage to allow for proper air diffusion.

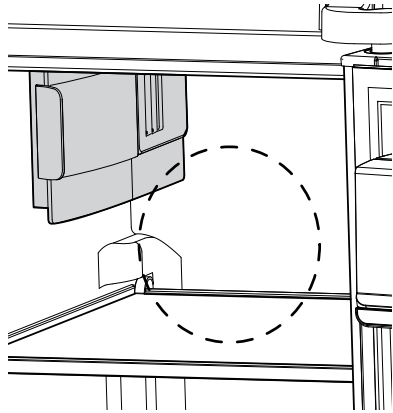

To order replacement filters, please visit our online store at [Frigidaire.com](http://Frigidaire.com), by calling toll-free at 1 (800) 372-4432, or by visiting the dealer where you purchased your unit. Here are the product numbers to request when ordering:

**PureAir Ultra II** Air Filter  
Part# **PAULTRA2**



## Protecting your investment

Keeping your appliance clean maintains appearance and prevents odor build-up. Wipe up any spills immediately and clean the freezer and refrigerator compartments at least twice a year. When cleaning, take the following precautions:

- Never use CHLORIDE or cleaners with bleach to clean stainless steel.
- Do not wash any removable parts in a dishwasher.
- Always unplug the electrical power cord from the wall outlet before cleaning.
- Remove adhesive labels by hand. Do not use razor blades or other sharp instruments which can scratch the appliance surface.
- Do not remove the serial plate.

Do not use abrasive cleaners such as window sprays, scouring cleansers, brushes, flammable fluids, cleaning waxes, concentrated detergents, bleaches or cleansers containing petroleum products on plastic parts, interior doors, gaskets or cabinet liners. Do not use paper towels, metallic scouring pads, or other abrasive cleaning materials or strong alkaline solutions.



### NOTE

If you set your temperature controls to turn off cooling, power to lights and other electrical components will continue until you unplug the power cord from the wall outlet.



### CAUTION

- Pull the unit straight out to move it. Shifting it from side to side may damage flooring. Be careful not to move the appliance beyond the plumbing connections.
- Damp objects stick to cold metal surfaces. Do not touch refrigerated surfaces with wet or damp hands.
- Sudden temperature changes can cause glass breakage.



### IMPORTANT

If you store or move your unit in freezing temperatures, be sure to completely drain the water supply system. Failure to do so could result in water leaks when you put the unit back into service. Contact a service representative to perform this operation.

# 26 CARE AND CLEANING

## Glass Shelves

### CAUTION

To avoid personal injury or property damage, handle tempered glass shelves carefully. Shelves may break suddenly if nicked, scratched, or exposed to sudden temperature change. Allow the glass shelves to stabilize to room temperature before cleaning. Do not wash in the dishwasher.

**Refrigerator:** Shelves are easily adjusted to suit individual needs. Before adjusting the shelves, remove all food. Shelves are supported by side rails.

To adjust, lift up on the back of the shelf and pull forward.

Replace the shelf by sliding it on top of the formed rails on the side walls of the cabinet until the rear plastic hooks of the shelf lock into the rear of the cabinet liner.

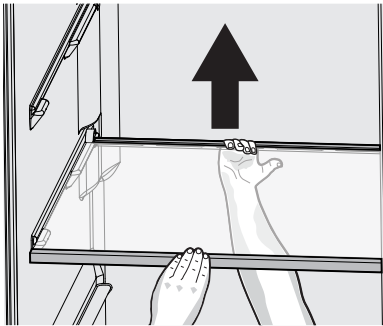

Refrigerator Glass Shelf

### CAUTION

To avoid personal injury or property damage, handle the freezer glass shelves carefully. These shelves are fixed and are not to be used as sliding shelves.

**Freezer:** You can remove the glass freezer shelf for cleaning. Remove all food from the glass shelf. Rotate the front trim down to remove front trim (Figure 1).

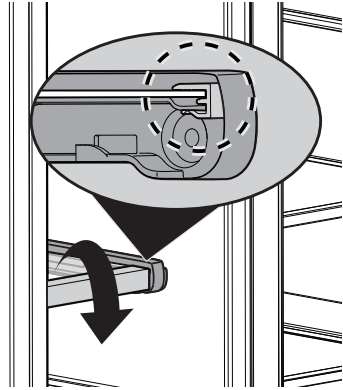

Figure 1

Remove both the rear trim and glass by pulling up on the rear tab and sliding the shelf forward (Figure 2)

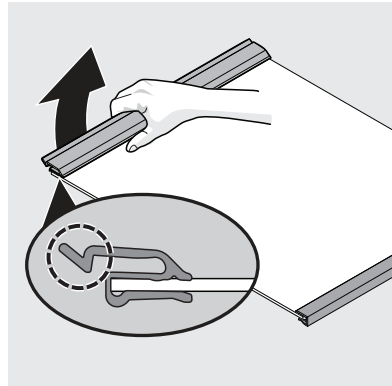

Figure 2

### CAUTION

Allow the glass shelves to stabilize to room temperature before cleaning. Do not wash in the dishwasher.

To reassemble the freezer shelf, slide the glass and rear trim along the shelf rails while pressing the shelf downward until it is fully locked into place in the rear (Figure 3).

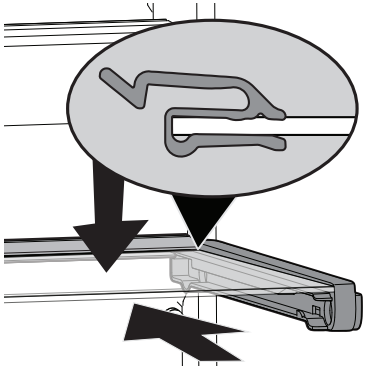

Figure 3

Finally, rotate the front trim upward on the front edge of the glass shelf (Figure 4).

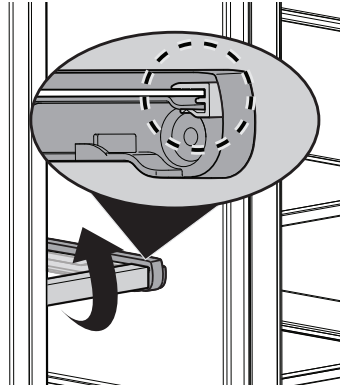

Figure 4

# 28 CARE AND CLEANING

Care & Cleaning Tips		
Part	What To Use	Tips and Precautions
<b>Interior &amp; Door Liners</b>	<ul style="list-style-type: none"> <li>• Soap and water</li> <li>• Baking soda and water</li> </ul>	Use 2 Tbsp of baking soda in 1 qt of warm water. <b>Be sure to wring excess water out of sponge or cloth before cleaning around controls, light bulb or any electrical part.</b>
<b>Door Gaskets</b>	<ul style="list-style-type: none"> <li>• Soap and water</li> </ul>	Wipe gaskets with a clean soft cloth.
<b>Drawers &amp; Bins</b>	<ul style="list-style-type: none"> <li>• Soap and water</li> </ul>	Use a soft cloth to clean drawer runners and tracks.
<b>Glass Shelves</b>	<ul style="list-style-type: none"> <li>• Soap and water</li> <li>• Glass cleaner</li> <li>• Mild liquid sprays</li> </ul>	See <b>Glass shelves</b> in <b>CARE AND CLEANING</b> before cleaning. Allow glass to warm to room temperature before immersing in warm water.
<b>Toe Grille</b>	<ul style="list-style-type: none"> <li>• Soap and water</li> <li>• Mild liquid sprays</li> <li>• Vacuum attachment</li> </ul>	Vacuum dust from front of toe grille. Remove toe grille (see Installation Instructions). Vacuum backside, wipe with sudsy cloth or sponge. Rinse and dry.
<b>Exterior &amp; Handles</b>	<ul style="list-style-type: none"> <li>• Soap and water</li> <li>• Non Abrasive Glass Cleaner</li> </ul>	Do not use commercial household cleaners containing ammonia, bleach or alcohol to clean handles. Use a soft cloth to clean smooth handles. <b>DO NOT use a dry cloth to clean smooth doors.</b>
<b>Exterior &amp; Handles (Stainless Steel Models Only)</b>	<ul style="list-style-type: none"> <li>• Soap and water</li> <li>• Stainless Steel Cleaners</li> </ul>	<b>Never use CHLORIDE or cleaners with bleach to clean stainless steel.</b> Clean stainless steel front and handles with non-abrasive soapy water and a dishcloth. Rinse with clean water and a soft cloth. Use a non-abrasive stainless steel cleaner. These cleaners can be purchased at most home improvement or major department stores. Always follow manufacturer's instructions. Do not use household cleaners containing ammonia or bleach. <b>NOTE: Always clean, wipe and dry with the grain to prevent scratching.</b> Wash the rest of the cabinet with warm water and mild liquid detergent. Rinse well, and wipe dry with a clean soft cloth.

Let us help you troubleshoot your concern! This section will help you with common issues. If you need us, visit our website, chat with an agent, or call us. We may be able to help you avoid a service visit. If you do need service, we can get that started for you!

**1-800-374-4432 (United States)**  
**Frigidaire.com**

**1-800-265-8352 (Canada)**  
**Frigidaire.ca**

<b>CONCERN</b>	<b>CAUSE</b>	<b>SOLUTION</b>
<b>AUTOMATIC ICE MAKER</b>		
<b>Ice maker is not making any ice.</b>	<ul style="list-style-type: none"> <li>• The ice maker is not on.</li> </ul>	<ul style="list-style-type: none"> <li>• Turn the ice maker on. Press and hold the <b>Ice Maker</b> button for 3 seconds until the indicator light is on.</li> </ul>
<b>Ice maker is not making enough ice.</b>	<ul style="list-style-type: none"> <li>• Check to see if water dispenser is dispensing slower than normal.</li> <li>• Freezer control is set too warm.</li> </ul>	<ul style="list-style-type: none"> <li>• If it is, replace the ice and water filter cartridge.</li> <li>• Set freezer control to colder setting to improve performance of the ice maker. Allow 24 hours for temperature to stabilize.</li> </ul>
<b>Ice cubes are freezing together.</b>	<ul style="list-style-type: none"> <li>• Ice cubes are not being used frequently enough.</li> <li>• Ice cubes are hollow (partially frozen cubes with water inside).</li> <li>• Freezer control is set too warm.</li> </ul>	<ul style="list-style-type: none"> <li>• Remove ice container and discard ice from container. Ice maker will produce fresh supply.</li> <li>• The ice and water filter cartridge may be clogged. Replace filter cartridge.</li> <li>• Set freezer control to colder setting. Allow 24 hours for temperature to stabilize.</li> </ul>
<b>DISPENSER (Ice &amp; Water)</b>		
<b>Dispenser will not dispense ice.</b>	<ul style="list-style-type: none"> <li>• There is no ice in the bin to be dispensed.</li> <li>• The refrigerator doors are not completely closed.</li> <li>• Dispenser paddle has been pressed too long and the dispenser motor has overheated.</li> <li>• Not dispensing ice regularly may melt and refreeze ice causing ice clumping. Dispensing clumps could damage the ice bucket.</li> </ul>	<ul style="list-style-type: none"> <li>• See the <b>Ice maker is not making any ice</b> section above.</li> <li>• Be sure to close the refrigerator completely.</li> <li>• The motor overload protector will reset in about 3 minutes and then ice can be dispensed.</li> <li>• Empty the ice bucket monthly or regularly dispense ice. For longer periods of time (vacation or vacant homes) see <b>Ice Maker/Dispenser Tips</b> in the <b>AUTOMATIC ICE AND WATER DISPENSER</b> section to turn off the ice maker.</li> </ul>
<b>Ice dispenser is jammed.</b>	<ul style="list-style-type: none"> <li>• Ice has melted and frozen around auger due to infrequent use, temperature fluctuations, and/or power outages.</li> <li>• Ice cubes are jammed between ice maker and back of ice container.</li> </ul>	<ul style="list-style-type: none"> <li>• Remove ice container, thaw, and empty the contents. Clean container, wipe dry, and replace in proper position. When new ice is made, dispenser should operate. See <b>Cleaning the Ice Storage Bin</b> in the <b>AUTOMATIC ICE AND WATER DISPENSER</b> section.</li> <li>• Remove ice cubes that are jamming the dispenser.</li> </ul>

# 30 TROUBLESHOOTING

CONCERN	CAUSE	SOLUTION
<b>DISPENSER (Ice &amp; Water) (Continued)</b>		
<b>Dispenser will not dispense water.</b>	<ul style="list-style-type: none"> <li>• Water filter not seated properly.</li> <li>• Water filter is clogged.</li> <li>• Household water line valve is not open.</li> </ul>	<ul style="list-style-type: none"> <li>• Remove and reinstall the water filter. Be sure to push the filter firmly so that you hear it lock solidly into position.</li> <li>• Replace filter cartridge. Be sure to remove protective caps and push the filter firmly so that you hear it lock solidly into position.</li> <li>• Open the household water line valve.</li> </ul>
<b>Water has an odd taste and/or odor.</b>	<ul style="list-style-type: none"> <li>• Water has not been dispensed for an extended period of time.</li> <li>• Unit not properly connected to cold water line.</li> </ul>	<ul style="list-style-type: none"> <li>• Draw and discard 10-12 glasses of water to freshen the supply.</li> <li>• Connect unit to cold water line that supplies water to the kitchen faucet.</li> </ul>
<b>Water pressure is extremely low.</b>	<ul style="list-style-type: none"> <li>• Cut-off and cut-on pressures are too low (well systems only).</li> <li>• Reverse osmosis system is in regenerative phase.</li> </ul>	<ul style="list-style-type: none"> <li>• Have someone turn up the cut-off and cut-on pressure on the water pump system (well systems only).</li> <li>• It is normal for a reverse osmosis system to be below 20 psi during the regenerative phase.</li> <li>• See the <b>WATER SUPPLY CONNECTION</b> section.</li> </ul>
<b>Water not cold enough.</b>	<ul style="list-style-type: none"> <li>• As warmer tap water goes through the filter and enters the water tank the chilled water is pushed through to the dispenser. Once the chilled water is used up it will take several hours to bring the freshly replaced water to a cooler temperature.</li> <li>• Some models are designed without a water tank, these water dispensing systems are not designed to chill water.</li> </ul>	<ul style="list-style-type: none"> <li>• Add ice to cup or container before dispensing water.</li> <li>• Add ice to cup or container before dispensing water</li> </ul>
<b>OPENING/CLOSING OF DOORS/DRAWERS</b>		
<b>Door(s) will not close.</b>	<ul style="list-style-type: none"> <li>• Door was closed too hard, causing other door to open slightly.</li> <li>• Refrigerator is not level. It rocks on the floor when moved slightly.</li> <li>• Refrigerator is touching a wall or cabinet.</li> </ul>	<ul style="list-style-type: none"> <li>• Close both doors gently.</li> <li>• Ensure floor is level and solid, and can adequately support the refrigerator. Contact a carpenter to correct a sagging or sloping floor.</li> <li>• Ensure floor is level and solid, and can adequately support the refrigerator. Contact a carpenter to correct a sagging or sloping floor.</li> </ul>

CONCERN	CAUSE	SOLUTION
<b>OPENING/CLOSING OF DOORS/DRAWERS (Continued)</b>		
<b>Drawers are difficult to move.</b>	<ul style="list-style-type: none"> <li>• Food is touching shelf on top of drawer.</li> <li>• Track that drawers slide on is dirty.</li> </ul>	<ul style="list-style-type: none"> <li>• Remove top layer of items in drawer.</li> <li>• Ensure drawer is properly installed on track.</li> <li>• Clean drawer, rollers, and track. See <b>CARE &amp; CLEANING</b>.</li> </ul>
<b>RUNNING OF REFRIGERATOR</b>		
<b>Compressor does not run.</b>	<ul style="list-style-type: none"> <li>• Freezer control is set to "OF" or "O".</li> <li>• Refrigerator is in defrost cycle.</li> <li>• Plug at electrical outlet is disconnected.</li> <li>• House fuse blown or tripped circuit breaker.</li> <li>• Power outage.</li> </ul>	<ul style="list-style-type: none"> <li>• Set freezer control.</li> <li>• This is normal for a fully automatic defrost refrigerator. The defrost cycle occurs periodically, lasting about 30 minutes.</li> <li>• Ensure plug is tightly pushed into outlet.</li> <li>• Check/replace fuse with a 15 amp time-delay fuse. Reset circuit breaker.</li> <li>• Check house lights. Call local electric company.</li> </ul>
<b>Refrigerator runs too much or too long.</b>	<ul style="list-style-type: none"> <li>• Room or outside weather is hot.</li> <li>• Doors are opened too frequently or too long.</li> <li>• Refrigerator/freezer door may be slightly open.</li> <li>• Freezer control is set too cold.</li> <li>• Refrigerator/freezer gasket is dirty, worn, cracked, or poorly fitted.</li> <li>• Condenser is dirty.</li> </ul>	<ul style="list-style-type: none"> <li>• It's normal for the refrigerator to work longer under these conditions.</li> <li>• Warm air entering the refrigerator causes it to run more. Open doors less often.</li> <li>• Ensure refrigerator is level. Keep food and contains from blocking door. See <b>CONCERN</b> column <b>OPENING/CLOSING OF DOORS/DRAWERS</b>.</li> <li>• Set Refrigerator control to warmer setting until refrigerator temperature is satisfactory. Allow 24 hours for temperature to stabilize.</li> <li>• Clean or change gasket. Leaks in door seal will cause refrigerator to run longer in order to maintain desired temperatures.</li> <li>• Clean condenser. See <b>CARE &amp; CLEANING</b>.</li> </ul>
<b>Appliance seems to run continuously.</b>	<ul style="list-style-type: none"> <li>• Today's refrigerators are designed with a variable speed compressor to be more energy efficient than previous models. This means your compressor reacts quickly to temperature fluctuations and circulates cold air based off your use and room temperature.</li> </ul>	<ul style="list-style-type: none"> <li>• This is normal for a variable speed compressor refrigerator; however, if you have concerns, call 1-800-374-4432 (United States) Frigidaire.com or 1-800-265-8352 (Canada) Frigidaire.ca.</li> </ul>
<b>DIGITAL TEMPERATURE DISPLAY</b>		
<b>Digital temperature displays are flashing.</b>	<ul style="list-style-type: none"> <li>• Electronic control system has detected a performance problem.</li> </ul>	<ul style="list-style-type: none"> <li>• Call your Frigidaire service representative, who can interpret any messages or number codes flashing on the digital displays.</li> </ul>

# 32 TROUBLESHOOTING

CONCERN	CAUSE	SOLUTION
<b>WATER/MOISTURE/FROST INSIDE REFRIGERATOR</b>		
<b>Moisture collects on inside of refrigerator walls.</b>	<ul style="list-style-type: none"> <li>Weather is hot and humid.</li> <li>Door is slightly open.</li> </ul>	<ul style="list-style-type: none"> <li>The rate of frost buildup and internal sweating increases.</li> <li>See <b>CONCERN</b> column <b>OPENING/CLOSING OF DOORS/DRAWERS</b>.</li> </ul>
<b>Water collects on bottom side of drawer cover.</b>	<ul style="list-style-type: none"> <li>Vegetables contain and give off moisture.</li> </ul>	<ul style="list-style-type: none"> <li>It is not unusual to have moisture on the bottom side of the cover.</li> <li>Move humidity control (some models) to lower setting.</li> </ul>
<b>Water collects in bottom of drawer.</b>	<ul style="list-style-type: none"> <li>Washed vegetables and fruit drain while in the drawer.</li> </ul>	<ul style="list-style-type: none"> <li>Dry items before putting them in the drawer. Water collecting in bottom of drawer is normal.</li> </ul>
<b>Stored products on top shelf freeze.</b>	<ul style="list-style-type: none"> <li>Fresh food temperature setting too cold.</li> <li>Certain products stored too close to damper / air filter housing.</li> </ul>	<ul style="list-style-type: none"> <li>Adjust fresh food temperature settings.</li> <li>Reconfigure top shelf storage to allow proper diffusion of air. See <b>Damper/Air Filter Housing</b> in the <b>FILTER REPLACEMENT</b> section.</li> </ul>
<b>WATER/MOISTURE/FROST OUTSIDE REFRIGERATOR</b>		
<b>Moisture collects on outside of refrigerator or between doors.</b>	<ul style="list-style-type: none"> <li>Weather is humid.</li> <li>Door is slightly open, causing cold air from inside refrigerator to meet warm air from outside.</li> </ul>	<ul style="list-style-type: none"> <li>This is normal in humid weather. When humidity is lower, the moisture should disappear.</li> <li>See <b>CONCERN</b> column <b>OPENING/CLOSING OF DOORS/DRAWERS</b>.</li> </ul>
<b>LED LIGHTING</b>		
<b>LED is not on</b>	<ul style="list-style-type: none"> <li>LED needs to be replaced.</li> </ul>	<ul style="list-style-type: none"> <li>Call a qualified service technician to replace the LED.</li> </ul>



Your appliance is covered by a one year limited warranty. For one year from your original date of purchase, Electrolux will pay all costs for repairing or replacing any parts of this appliance that prove to be defective in materials or workmanship when such appliance is installed, used and maintained in accordance with the provided instructions.

## Exclusions

### This warranty does not cover the following:

1. Products with original serial numbers that have been removed, altered or cannot be readily determined.
2. Product that has been transferred from its original owner to another party or removed outside the USA or Canada.
3. Rust on the interior or exterior of the unit.
4. Products purchased "as-is" are not covered by this warranty.
5. Food loss due to any refrigerator or freezer failures.
6. Products used in a commercial setting.
7. Service calls which do not involve malfunction or defects in materials or workmanship, or for appliances not in ordinary household use or used other than in accordance with the provided instructions.
8. Service calls to correct the installation of your appliance or to instruct you how to use your appliance.
9. Expenses for making the appliance accessible for servicing, such as removal of trim, cupboards, shelves, etc., which are not a part of the appliance when it is shipped from the factory.
10. Service calls to repair or replace appliance light bulbs, air filters, water filters, other consumables, or knobs, handles, or other cosmetic parts.
11. Surcharges including, but not limited to, any after hour, weekend, or holiday service calls, tolls, ferry trip charges, or mileage expense for service calls to remote areas, including the state of Alaska.
12. Damages to the finish of appliance or home incurred during installation, including but not limited to floors, cabinets, walls, etc.
13. Damages caused by: services performed by unauthorized service companies; use of parts other than genuine Electrolux parts or parts obtained from persons other than authorized service companies; or external causes such as abuse, misuse, inadequate power supply, accidents, fires, or acts of God.

## DISCLAIMER OF IMPLIED WARRANTIES; LIMITATION OF REMEDIES

CUSTOMER'S SOLE AND EXCLUSIVE REMEDY UNDER THIS LIMITED WARRANTY SHALL BE PRODUCT REPAIR OR REPLACEMENT AS PROVIDED HEREIN. CLAIMS BASED ON IMPLIED WARRANTIES, INCLUDING WARRANTIES OF MERCHANTABILITY OR FITNESS FOR A PARTICULAR PURPOSE, ARE LIMITED TO ONE YEAR OR THE SHORTEST PERIOD ALLOWED BY LAW, BUT NOT LESS THAN ONE YEAR. ELECTROLUX SHALL NOT BE LIABLE FOR CONSEQUENTIAL OR INCIDENTAL DAMAGES SUCH AS PROPERTY DAMAGE AND INCIDENTAL EXPENSES RESULTING FROM ANY BREACH OF THIS WRITTEN LIMITED WARRANTY OR ANY IMPLIED WARRANTY. SOME STATES AND PROVINCES DO NOT ALLOW THE EXCLUSION OR LIMITATION OF INCIDENTAL OR CONSEQUENTIAL DAMAGES, OR LIMITATIONS ON THE DURATION OF IMPLIED WARRANTIES, SO THESE LIMITATIONS OR EXCLUSIONS MAY NOT APPLY TO YOU. THIS WRITTEN WARRANTY GIVES YOU SPECIFIC LEGAL RIGHTS. YOU MAY ALSO HAVE OTHER RIGHTS THAT VARY FROM STATE TO STATE.

## If You Need Service

Keep your receipt, delivery slip, or some other appropriate payment record to establish the warranty period should service be required. If service is performed, it is in your best interest to obtain and keep all receipts. Service under this warranty must be obtained by contacting Electrolux at the addresses or phone numbers below.

This warranty only applies in the USA and Canada. In the USA, your appliance is warranted by Electrolux Major Appliances North America, a division of Electrolux Home Products, Inc. In Canada, your appliance is warranted by Electrolux Canada Corp. Electrolux authorizes no person to change or add to any obligations under this warranty. Obligations for service and parts under this warranty must be performed by Electrolux or an authorized service company. Product features or specifications as described or illustrated are subject to change without notice.

**USA**  
**1-800-374-4432**  
Frigidaire  
10200 David Taylor Drive  
Charlotte, NC 28262



**Electrolux**

**Canada**  
**1.800.265.8352**  
Electrolux Canada Corp.  
5855 Terry Fox Way  
Mississauga, Ontario, Canada  
L5V 3E4

# FRIGIDAIRE®

welcome **home**

Our home is your home. Visit us if you need help with any of these things:



owner support



accessories



service



registration

(See your registration card for more information.)

Frigidaire.com  
1-800-374-4432

Frigidaire.ca  
1-800-265-8352

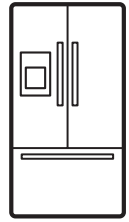

# REFRIGERATOR

## *use & care*

Introduction.....	2	Ice Maker .....	29
Important Safety Information .....	3	Storage Features.....	31
Features.....	6	Storing Food and Saving Energy.....	36
Installation .....	8	Normal Operating Sounds.....	37
Door Removal.....	11	Filter Replacement.....	38
Door Handle Installation.....	16	Care & Cleaning .....	41
Water Supply Connection.....	17	Troubleshooting .....	43
Controls and Settings.....	19	Limited Warranty .....	48
Automatic Ice & Water Dispenser .....	26		

## Welcome to our family

Thank you for bringing Frigidaire into your home! We see your purchase as the beginning of a long relationship together.

This manual is your resource for the use and care of your product. Please read it before using your appliance. Keep it handy for quick reference. If something doesn't seem right, the troubleshooting section will help you with common issues.

FAQs, helpful tips and videos, cleaning products, and kitchen and home accessories are available at [www.frigidaire.com](http://www.frigidaire.com).

We are here for you! Visit our website, chat with an agent, or call us if you need help. We may be able to help you avoid a service visit. If you do need service, we can get that started for you.

Let's make it official! Be sure to register your product.

Keep your product info here so it's easy to find.

Model Number \_\_\_\_\_

Serial Number \_\_\_\_\_

Purchase Date \_\_\_\_\_

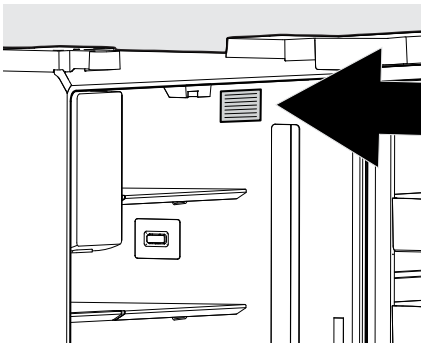

Serial Number Location



## Installation Checklist

### Doors

- Handles are secure and tight
- Door seals completely to cabinet on all sides

### Leveling

- Refrigerator is level side-to-side and slightly elevated in front to assist with door and drawer closing (front should be higher than back)
- Cabinet is setting solid on all corners

### Electrical Power

- House power turned on
- Refrigerator plugged in

### Ice Maker

- House water supply connected to refrigerator
- WARNING: Potable water supply only.**
- No water leaks present at all connections - recheck in 24 hours
- Ice maker is turned ON
- Ice & water dispenser operates correctly

### Final Checks

- Shipping material removed
- Fresh food and freezer temperatures set
- Crisper humidity controls set
- Registration card sent in



## WARNING

Please read all instructions before using this appliance.

### Safety Definitions

 This is the safety alert symbol. It is used to alert of potential personal injury hazards. Obey all safety messages that follow this symbol to avoid possible injury or death.



## DANGER

DANGER indicates an imminently hazardous situation which, if not avoided, will result in death or serious injury.



## WARNING

WARNING indicates a potentially hazardous situation which, if not avoided, could result in death or serious injury.



## CAUTION

CAUTION indicates a potentially hazardous situation which, if not avoided, may result in minor or moderate injury.



## IMPORTANT

IMPORTANT indicates installation, operation or maintenance information which is important but not hazard-related.



## DANGER



DANGER Risk of fire or explosion. Flammable refrigerant used. Do not use mechanical devices to defrost refrigerator. Do not puncture refrigerant tubing.

DANGER Risk of fire or explosion. Flammable refrigerant used. To be repaired only by trained service personnel. Use only manufacturer-authorized service parts. Any repair equipment used must be designed for flammable refrigerants. Follow all manufacturer repair instructions. Do not puncture refrigerant tubing.



## CAUTION



CAUTION Risk of fire or explosion. Dispose of refrigerator properly in accordance with the applicable federal or local regulations. Flammable refrigerant used.

CAUTION Risk of fire or explosion due to puncture of refrigerant tubing. Follow handling instructions carefully. Flammable refrigerant used.



## WARNING

**CALIFORNIA RESIDENTS ONLY**  
**WARNING! Cancer and Reproductive Harm**  
**[www.P65Warnings.ca.gov](http://www.P65Warnings.ca.gov)**

# 4

## IMPORTANT SAFETY INFORMATION

### Child Safety

Destroy or recycle the carton, plastic bags, and any exterior wrapping material immediately after the refrigerator is unpacked. Children should **NEVER** use these items to play. Cartons covered with rugs, bedspreads, plastic sheets or stretch wrap may become airtight chambers, and can quickly cause suffocation.

### Safety Instructions

- DO NOT store or use gasoline, or other flammable liquids in the vicinity of this or any other appliance. Read product labels for warnings regarding flammability and other hazards.
- DO NOT operate the refrigerator in the presence of explosive fumes.
- Avoid contact with any moving parts of automatic ice maker.
- Remove all staples from the carton. Staples can cause severe cuts, and also destroy finishes if they come in contact with other appliances or furniture.

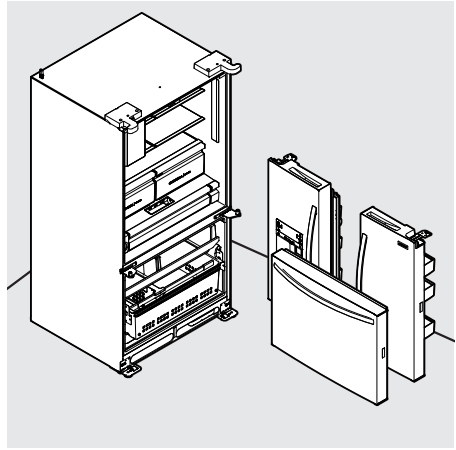

### Proper Disposal of Refrigerators/Freezers

We strongly encourage responsible appliance recycling/disposal methods. Check with your utility company or visit [www.energystar.gov/](http://www.energystar.gov/) recycle for more information on recycling your old refrigerator.

### Before you throw away your old refrigerator/freezer:

- Remove doors.
- Leave shelves in place so children may not easily climb inside.
- Have refrigerant removed by a qualified service technician.



### WARNING

Do not use electrical appliances inside the food storage compartments of the appliance unless they are of the type recommended by the manufacturer.

### Proper Disposal of your Refrigerator or Freezer

#### Risk of child entrapment

Child entrapment and suffocation are not problems of the past. Junked or abandoned refrigerators or freezers are still dangerous – even if they will sit for “just a few days”. If you are getting rid of your old refrigerator or freezer, please follow the instructions below to help prevent accidents.



### IMPORTANT

#### CFC/HCFC Disposal

Your old refrigerator may have a cooling system that used CFCs or HCFCs (chlorofluorocarbons or hydrochlorofluorocarbons). CFCs and HCFCs are believed to harm stratospheric ozone if released to the atmosphere. Other refrigerants may also cause harm to the environment if released to the atmosphere.

If you are throwing away your old refrigerator, make sure the refrigerant is removed for proper disposal by a qualified technician. If you intentionally release refrigerant, you may be subject to fines and imprisonment under provisions of environmental legislation.

## Electrical information

- The refrigerator must be plugged into its own dedicated 115 Volt, 60 Hz., 15 Amp, AC only electrical outlet. The power cord of the appliance is equipped with a three-prong grounding plug for your protection against electrical shock hazards. It must be plugged directly into a properly grounded three prong receptacle. The receptacle must be installed in accordance with local codes and ordinances. Consult a qualified electrician. Avoid connecting refrigerator to a Ground Fault Interrupter (GFI) circuit. Do not use an extension cord or adapter plug.
- If the power cord is damaged, it should be replaced by an authorized service technician to prevent any risk.
- Never unplug the refrigerator by pulling on the power cord. Always grip the plug firmly, and pull straight out from the receptacle to prevent damaging the power cord.
- Unplug the refrigerator before cleaning and before replacing a light bulb to avoid electrical shock.
- Performance may be affected if the voltage varies by 10% or more. Operating the refrigerator with insufficient power can damage the compressor. Such damage is not covered under your warranty.
- Do not plug the unit into an electrical outlet controlled by a wall switch or pull cord to prevent the refrigerator from being turned off accidentally.



## IMPORTANT

Pressing and holding the On/Off button for three seconds, located on the temperature control panel, will disable your refrigerator's cooling system but does not disconnect the power to the light bulb and other electrical components. To turn off power to your refrigerator you must unplug the power cord from the electrical outlet.

Grounding type wall receptacle

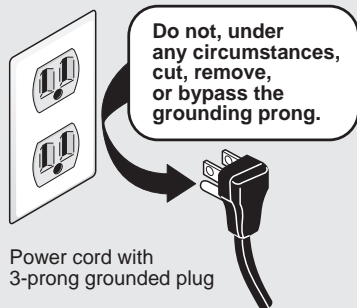

## CAUTION

To avoid personal injury or property damage, handle tempered glass shelves carefully. Shelves may break suddenly if nicked, scratched, or exposed to sudden temperature change.

# 6

## FEATURES

### External Water Dispenser Model

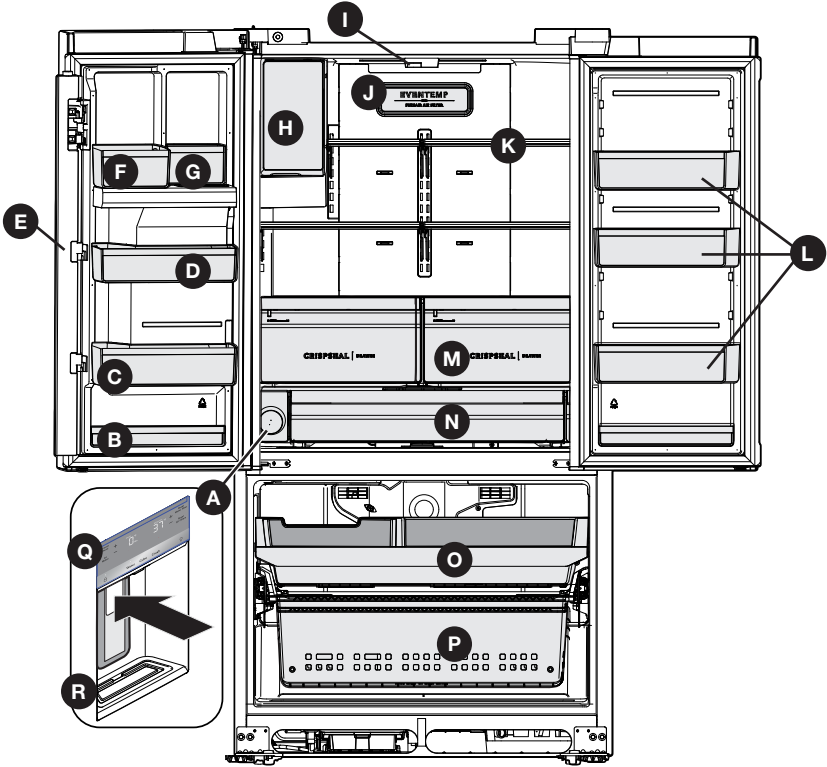

<b>A</b>	Water Filter
<b>B</b>	Condiment Bin
<b>C</b>	L-Shaped Bin
<b>D</b>	Dairy Bin
<b>E</b>	Flipper Mullion
<b>F</b>	Gallon Bin
<b>G</b>	Slim Bin
<b>H</b>	Fresh Food Ice Maker & Bin
<b>I</b>	Flipper Guide

<b>J</b>	Air Filter
<b>K</b>	Edge-to-edge Glass Shelving
<b>L</b>	Standard bin
<b>M</b>	Crisper Drawers
<b>N</b>	Deli Drawer
<b>O</b>	Upper Freezer Baskets
<b>P</b>	Lower Freezer Baskets
<b>Q</b>	External Control Display
<b>R</b>	Ice/Water Dispenser



### IMPORTANT

Accessories are available for your appliance and may be purchased at [Frigidaire.com](http://Frigidaire.com) or by calling 1-800-374-4432 (Frigidaire.ca or 1-800-265-8352 in Canada) or from an authorized seller.



Non- Dispenser Model

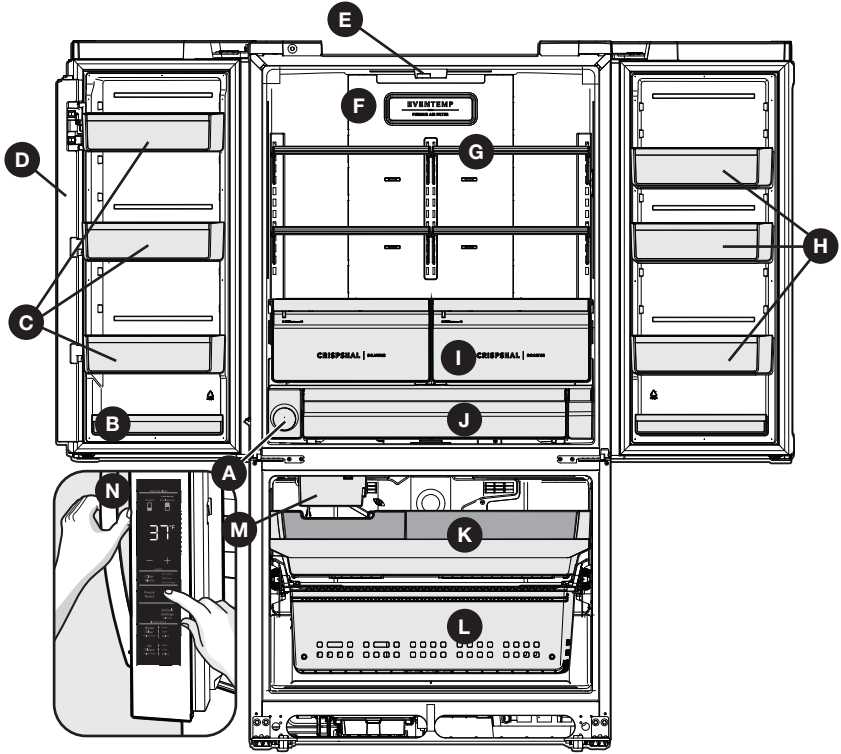

<b>A</b>	Water Filter
<b>B</b>	Condiment Bin
<b>C</b>	Gallon Bin
<b>D</b>	Flipper Mullion
<b>E</b>	Flipper Guide
<b>F</b>	Air Filter
<b>G</b>	Edge-to-edge Glass Shelving
<b>H</b>	Standard bin

<b>I</b>	Crisper Drawers
<b>J</b>	Deli Drawer
<b>K</b>	Upper Freezer Baskets
<b>L</b>	Lower Freezer Baskets
<b>M</b>	Freezer Ice maker
<b>N</b>	Non-Dispenser control (side door)

**→ IMPORTANT**

Accessories are available for your appliance and may be purchased at [Frigidaire.com](http://Frigidaire.com) or by calling 1-800-374-4432 (Frigidaire.ca or 1-800-265-8352 in Canada) or from an authorized seller.

# 8

## INSTALLATION

### Tools Necessary:

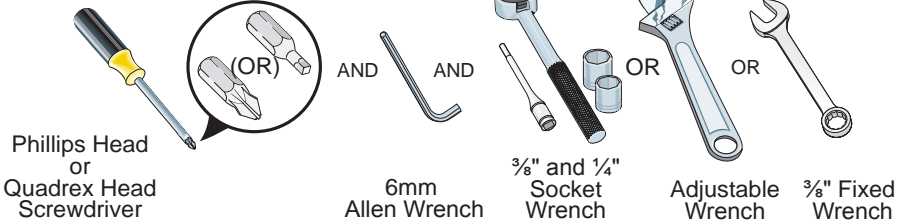

### Components Provided:

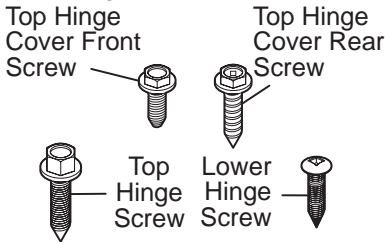

This Use & Care Manual provides general installation and operating instructions for your model. We recommend using a service or kitchen contracting professional to install your refrigerator. Use the refrigerator only as instructed in this Use & Care Manual. **Before starting the refrigerator, follow these important first steps.**

### Location

- Choose a place that is near a grounded, non-GFCI, electrical outlet. **Do Not** use an extension cord or an adapter plug.
- If possible, place the refrigerator out of direct sunlight and away from the range, dishwasher, or other heat sources.
- The refrigerator must be installed on a floor that is level and strong enough to support a fully loaded refrigerator.
- Consider water supply availability for models equipped with an automatic ice maker.



### WARNING

This appliance is intended to be used in household and similar applications such as:

- Staff kitchen areas in shops, offices and other working environments
- Farm houses and by clients in hotels, motels and other residential type environments
- Bed and breakfast type environments
- Catering and similar non-retail applications.



### CAUTION

Do Not install the refrigerator where the temperature will drop below 55°F (13°C) or rise above 110°F (43°C). The compressor will not be able to maintain proper temperatures inside the refrigerator.



### WARNING

#### Installation

Allow the following clearances for ease of installation, proper air circulation, and plumbing and electrical connections:

- Sides & Top  $\frac{3}{8}$  inch (9.5 mm)
- Back 1 inch (25.4 mm)

## NOTE

If your refrigerator is placed with the door hinge side against a wall, you may have to allow additional space so the door can be opened wider.

## Door opening

Your refrigerator should be positioned to allow easy access to a counter when removing food. For best use of refrigerator drawers and freezer baskets, the refrigerator should be in a position where both can be fully opened.

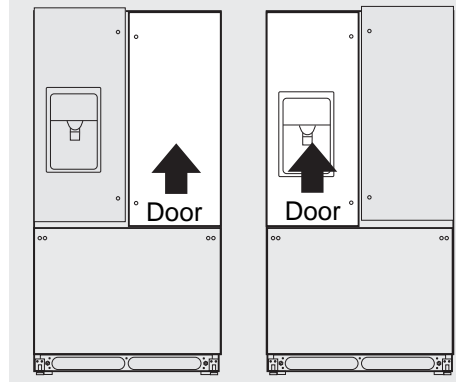

## Cabinet Leveling & Refrigerator Door Alignment (if necessary)

Guidelines for final positioning of refrigerator:

- All four corners of the cabinet must rest firmly on the floor.
- The front should be slightly elevated to ensure that doors close and seal properly.
- Doors should align with each other and be level.

Most of these conditions can be met by raising or lowering the adjustable anti-tip legs.

To level the cabinet using the anti-tip legs:

1. Slightly open freezer drawer to reveal anti-tip legs at bottom of cabinet.
2. Lower anti-tip legs until they are both touching the floor. Use a pair of pliers to adjust.

**To raise unit:** turn leg clockwise if looking from the top.

**To lower unit:** turn leg counterclockwise, looking from the top.

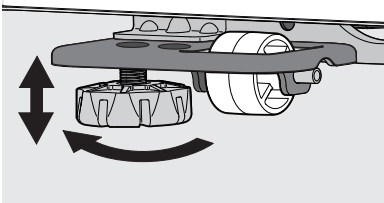

3. Ensure both doors are bind-free with their seals touching the cabinet on all four sides and that cabinet is stable.

## NOTE

Product is shipped with doors adjusted to the lowest position on the hinges.

To make final door height adjustments:

1. Open freezer drawer to access hinges for fresh food doors.
2. Insert 6mm Allen™ wrench into the shaft of the lower hinge. (Included with unit)

**To lower door:** turn adjustment screw counter-clockwise if looking at the door from below.

**To raise door:** turn adjustment screw clockwise if looking at the door from below.

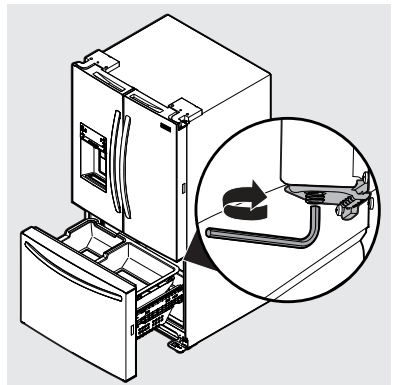

# 10 INSTALLATION

## Flipper Mullion

Adjust Flipper Mullion for proper connection with the mullion guide by ensuring the flipper mullion is folded and perpendicular to the fresh food door. If the mullion guide is not in the correct position, it could prevent the door from closing completely.

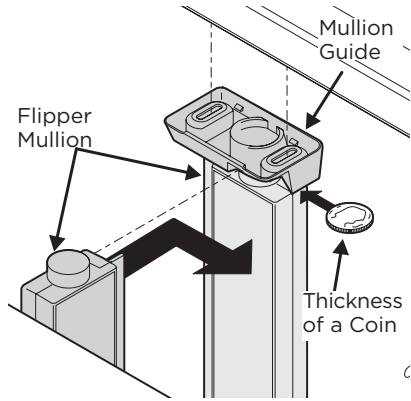
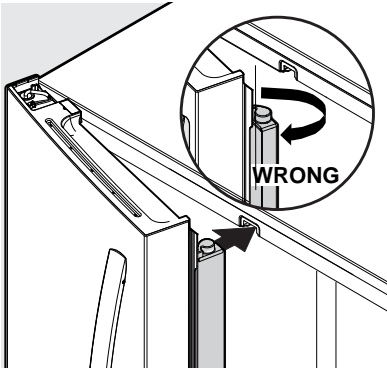

### Adjusting Flipper Mullion Height

3. Re-tighten screws.

### To adjust the flipper mullion:

1. Loosen the two screws located on the flipper mullion hinge.

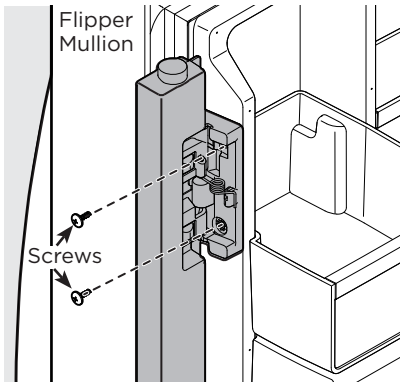

### Adjusting Flipper Mullion Screw

2. Adjust flipper mullion height. For proper connection with the flipper mullion guide, there should be a separation about the thickness of a coin (0.060 inches, or 1.5 mm) between the guide and flipper mullion.

### Getting through narrow spaces

If your refrigerator will not fit through an entrance area, you can remove the doors. Check first by measuring the entrance.

#### To prepare for removing the doors:

1. Make sure the electrical power cord is unplugged from the wall outlet.
2. Remove any food from the door shelves and close the doors.



#### WARNING

Make sure the electrical power cord is unplugged from the wall outlet.

#### To remove refrigerator doors:

1. Remove the three screws from both hinge covers on the left and right top of the cabinet, taking care not to damage electrical connections or sensors.

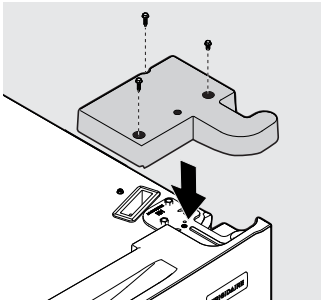

2. After the hinge covers are removed, disconnect any harnesses between the cabinet and doors by grasping both sides of the connector firmly, depress the latch and pull apart.

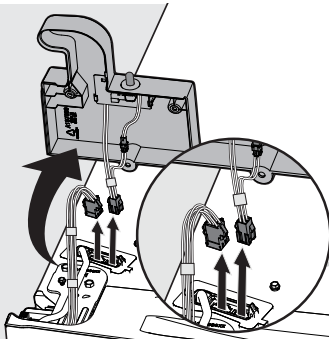

Left Door Dispenser Unit

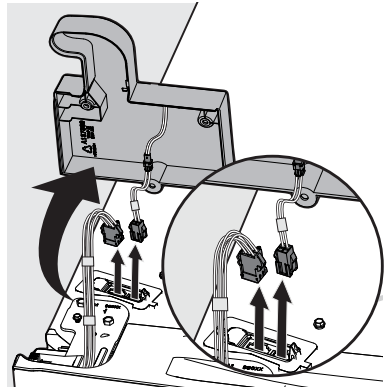

Left Door Non-Dispenser Unit

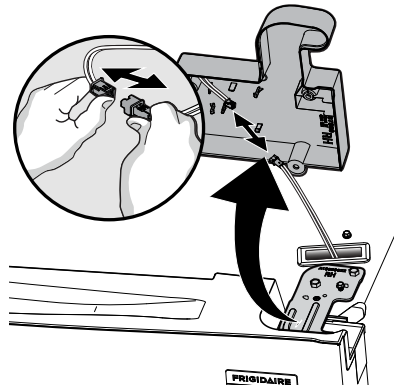

Right Door Dispenser Unit

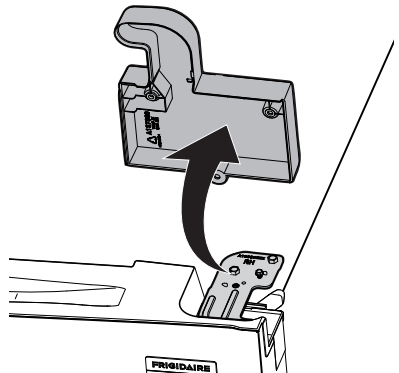

Right Door Non-Dispenser Unit

# 12 DOOR REMOVAL

- Trace lightly around the door's top hinges with a pencil. This makes re-installation easier.

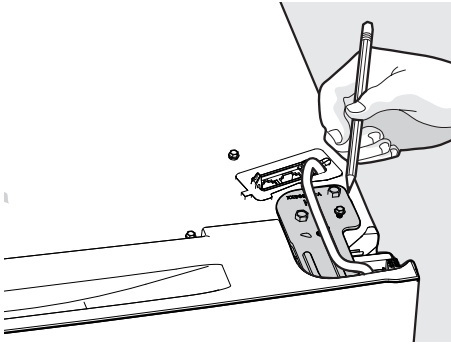

- Remove bulkhead cover at rear of unit to access water tubing. Disconnect the water tube at the push-lock connection on the rear of the unit below the bulkhead. The dispenser line is connected to the yellow water line coming from the main water valve.

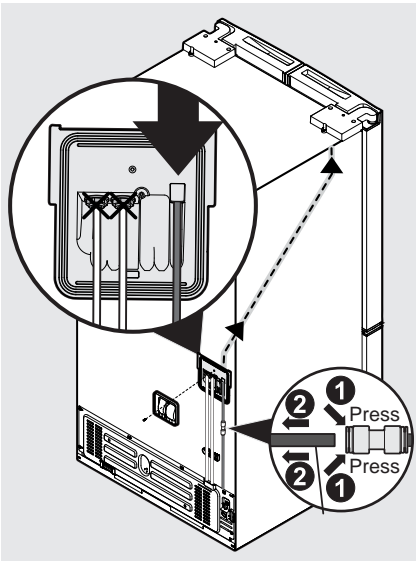

- Pull the water tube out of the conduit from the top of the cabinet.

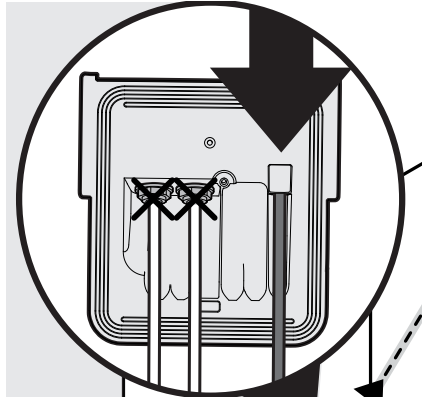

## NOTE

You will be pulling approximately five feet of water tube from the back of the refrigerator. Use care while pulling the water tube from the unit to be sure that you do not kink the tube.

- Open both doors to a 90 degree angle.

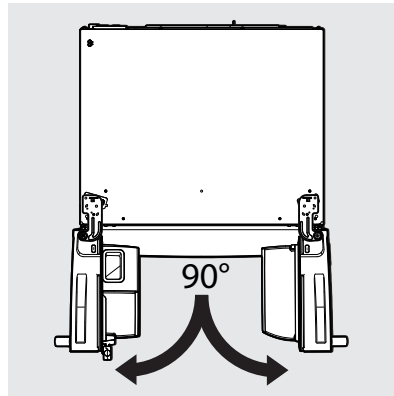

## CAUTION

Be sure doors are set aside in a secure position where they cannot fall and cause personal injury, or damage to the doors or handles.

- Remove hex screws from top hinge plate, then remove the top hinge.

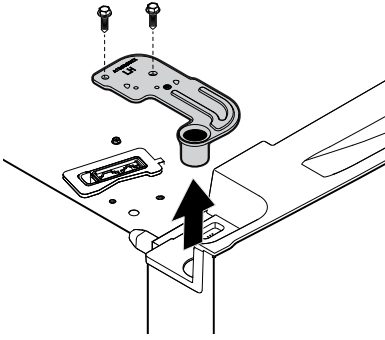

- Lift doors off bottom hinges and set aside.
- Unscrew the three bottom hinge screws and remove the bottom hinges.

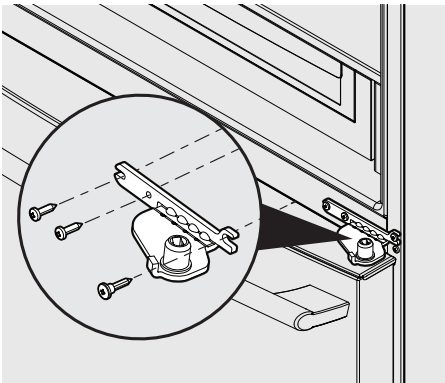

Lower Hinge Removal

### To reinstall the refrigerator doors:

- Replace three bottom hinge screws and hinges on both sides of the cabinet. Ensure screws are tightly snug to hinges on both sides of the cabinet before re-installing doors.
- Holding the door at a 90 degree angle, drop the pin down into the bottom hinge opening. Rotate it slightly in either direction until the door falls onto the hinge and is fully seated.

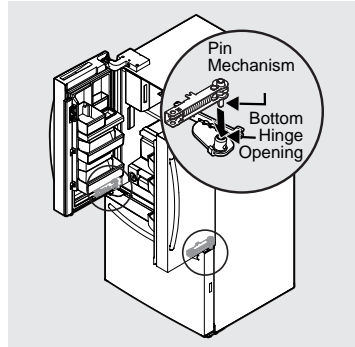

### NOTE

When reinserting the water tube and replacing the top hinge cover, use care to be sure you do not kink the tube. The water line may also be difficult to pass back through the conduit inside the cabinet

# 14 DOOR REMOVAL



## NOTE

Upon replacement, the tube needs to be fully inserted up to the marking line.

3. Reinstall top hinges and screws.
4. Insert and feed water line back into the conduit at the top left door hinge until tube re-appears at rear of unit.

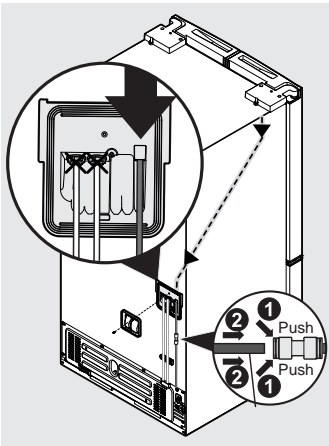

5. Reconnect all harnesses.
6. Replace top hinge covers and screws.
7. Reconnect water line to push-lock connection and reinstall water line bulkhead cover at rear of unit.
8. Reconnect electrical power cord to the wall outlet

## To reset door pin:

If doors are removed at less than a 40 degree angle, the pin returns to the home position. It can be reset by turning the door upside down and using a 5/32" Allen wrench to rotate the left hand pin 90 degrees clockwise and the right hand pin 90 degrees counterclockwise.

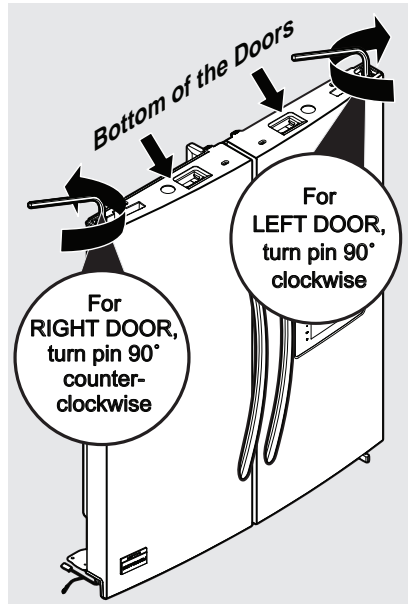

Once the door pins are reset, follow the steps "To reinstall the refrigerator doors".



## Removing Freezer Drawer



### CAUTION

Drawer is heavy. Use caution when lifting.

1. Remove 4 hex head drawer screws (2 per side) that secure the drawer to the slide assemblies.
2. Lift up drawer to remove.

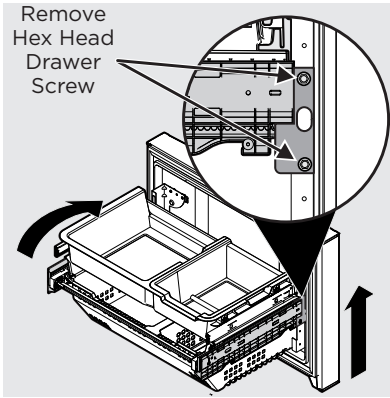

### CAUTION

Do Not loosen or remove the 3 hex screws.

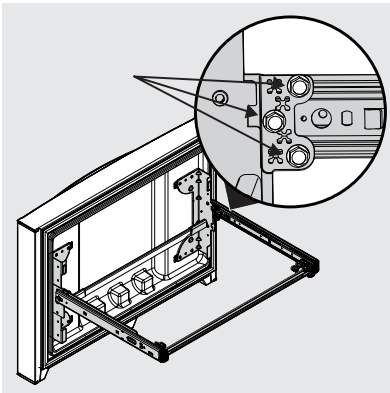

## Replacing Freezer Drawer

1. Extend the Freezer slides from the unit.
2. Carefully align support pin with hooks on end of freezer slides and then lower freezer door onto slides.
3. Replace the 4 hex head screws that secure the slides to the door (2 on each side) and tighten.

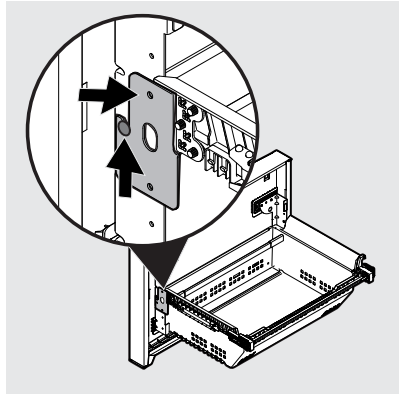

### NOTE

To locate the pin, look inside the drawer and the pin is next to the door liner and the slides. Not all parts are shown in the illustration.

**CAUTION**

Wear gloves and safety goggles. Use extreme CAUTION when installing these handles.

### Door Handle Mounting Instructions

1. Remove handles from carton and any other protective packaging.
2. Position refrigerator handle end caps over upper and lower pre-installed shoulder bolts (A) that are fastened into door, ensuring the holes for the set screws are facing towards the opposite door.
3. While holding handle firmly against door, fasten upper and lower Allen set screws (B) with supplied Allen wrench.
4. Repeat steps 2 and 3 to install opposite handle. Ensure the holes for the set screws are facing towards the opposite door.
5. Position freezer handle end caps over left and right pre-installed shoulder bolts (A) that are fastened to the door, ensuring the holes for the set screws are facing down.
6. While holding handle firmly against door, loosely tighten right Allen set screw (B) with supplied Allen wrench until there is no gap between handle and door.
7. Still holding the handle firmly to the door, firmly tighten left Allen set screw (B) with supplied Allen wrench.
8. Return to the right Allen set screw (B) and firmly tighten with supplied Allen wrench.

#### Mounting Refrigerator Handles

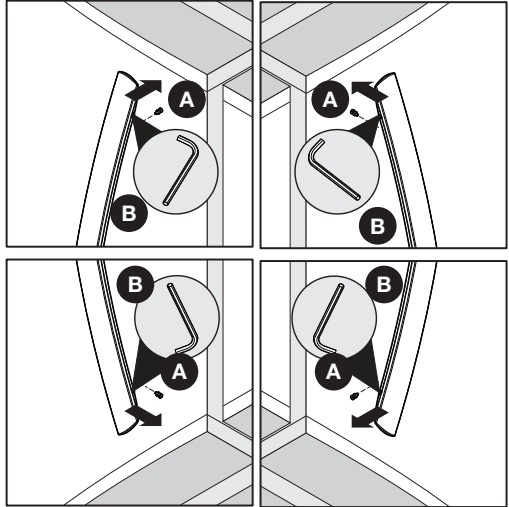

#### Mounting Freezer Handle

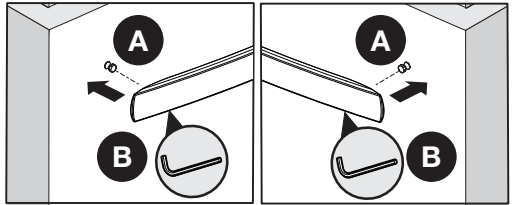
**NOTE**

When tightening the Allen set screws, it is important that force be applied to the longer arm of the Allen wrench supplied in the handle packaging.

**NOTE**

All set screws should be tightened so the screw is below the surface of the handle. The handles should be drawn tight to freezer and refrigerator doors with no gaps. Opening the opposite door while tightening the Allen screw makes installation easier. The door handle may loosen over time or if it was installed improperly. If this happens, tighten the set screws on the handles.



## WARNING

To avoid electric shock, which can cause death or severe personal injury, disconnect the refrigerator from electrical power before connecting a water supply line to the refrigerator.



## CAUTION

To Avoid Property Damage:

- Copper or Stainless Steel braided tubing is recommended for the water supply line. Water supply tubing made of ¼ inch plastic is not recommended to be used. Plastic tubing greatly increases the potential for water leaks, and the manufacturer will not be responsible for any damage if plastic tubing is used for the supply line.
- DO NOT install water supply tubing in areas where temperatures fall below freezing.
- Chemicals from a malfunctioning water softener can damage the ice maker. If your home has a water softening system, ensure the softener is maintained and working properly.



## IMPORTANT

Ensure that your water supply line connections comply with all local plumbing codes.

- A water supply line made of ¼ inch (6.4 mm) OD, copper or stainless steel tubing. To determine the length of tubing needed, measure the distance from the ice maker inlet valve at the back of the refrigerator to your cold water pipe. Then add approximately 6 ft. (1.8 meters), so the refrigerator can be moved out for cleaning (as shown).
- A shutoff valve to connect the water supply line to your household water system. DO NOT use a self-piercing type shutoff valve.
- Do not re-use compression fitting or use thread seal tape.
- A compression nut and ferrule (sleeve) for connecting a copper water supply line to the ice maker inlet valve.



## NOTE

Check with your local building authority for recommendations on water lines and associated materials prior to installing your new refrigerator. Depending on your local/state building codes, Frigidaire recommends for homes with existing valves its **Smart Choice**® water line kit 5305513409 with a 6 ft. (1.8 meters) Stainless Steel Water Line, and for homes without an existing valve Frigidaire recommends its **Smart Choice**® water line kit 5305510264 with a 20 ft. (6 meters) Copper Water Line with self-tapping saddle valve. Please refer to [www.frigidaire.com/store](http://www.frigidaire.com/store) for more information.

## Before Installing The Water Supply Line, You Will Need:

- Basic Tools: adjustable wrench, flat-blade screwdriver, and Phillips™ screwdriver
- Access to a household cold water line with water pressure between 30 and 100 psi.

## To Connect Water Supply Line To Ice Maker Inlet Valve

1. Disconnect refrigerator from electric power source.
2. Place end of water supply line into sink or bucket. Turn ON water supply and flush supply line until water is clear. Turn OFF water supply at shutoff valve.
3. Remove plastic cap from water valve inlet and discard cap.

4. If you use copper tubing - Slide brass compression nut, then ferrule (sleeve) onto water supply line. Push water supply line into water valve inlet as far as it will go ( $\frac{1}{4}$  inch/6.4 mm). Slide ferrule (sleeve) into valve inlet and finger tighten compression nut onto valve. Tighten another half turn with a wrench; DO NOT over tighten. See Figure 1.
- If you use braided flexible stainless steel tubing - The nut is already assembled on the tubing. Slide nut onto valve inlet and finger tighten nut onto valve. Tighten another half turn with a wrench; DO NOT over tighten. See Figure 2.
5. With steel clamp and screw, secure water supply line to rear panel of refrigerator as shown.
  6. Coil excess water supply line (copper tubing only), about  $2\frac{1}{2}$  turns, behind refrigerator as shown and arrange coils so they do not vibrate or wear against any other surface. Do not kink tubing.
  7. Turn ON water supply at shutoff valve and tighten any connections that leak.
  8. Reconnect refrigerator to electrical power source.
  9. To turn ice maker on, ensure Ice Maker is enabled on display (LED will be lit) or set the ice maker's On/off power switch to the "ON" position (freezer ice maker).

**NOTE**

These instructions do not cover after market ice maker installation. Instructions in after market ice maker kit should be used.

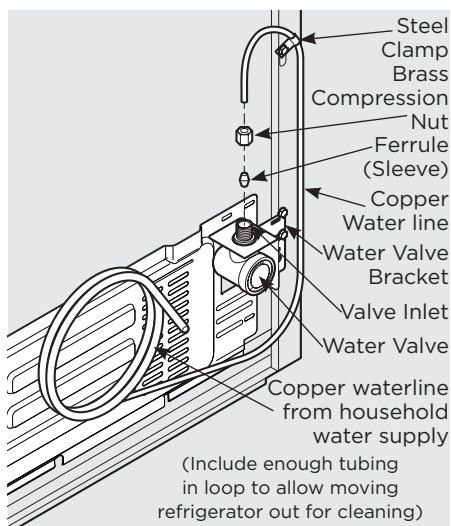
**Figure 1****IMPORTANT**

Your refrigerator's water supply system includes several tubing lines, a water filter, and a water valve. To ensure that your water dispenser works properly, this system must be completely filled with water when your refrigerator is first connected to the household water supply line.

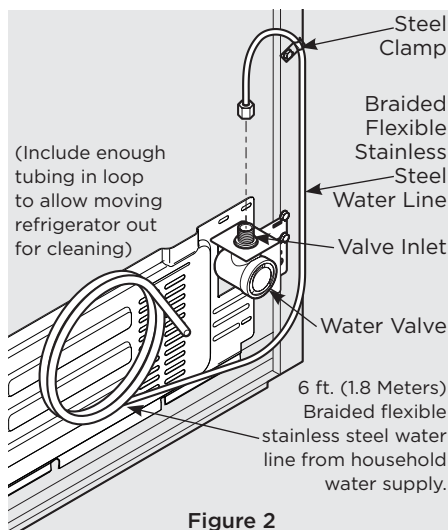
**Figure 2**

External Water Dispenser Control Display Mode Views

Sleep Mode Display

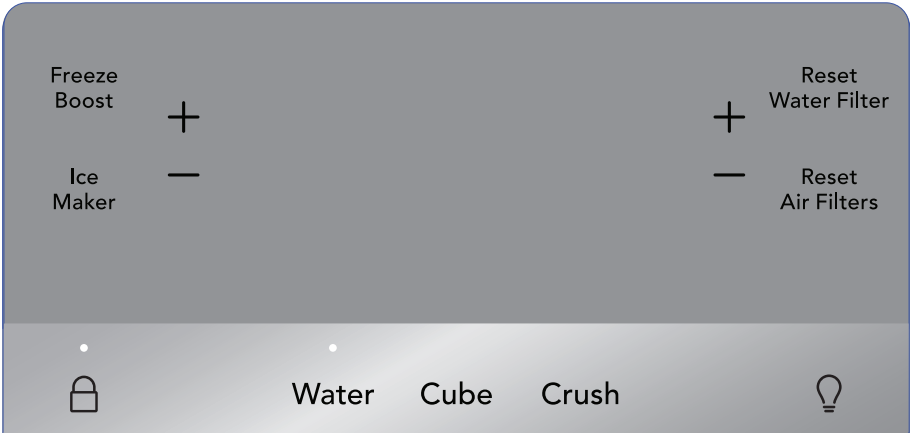

Sleep Mode

As a default, the display will go to sleep after a short time. If any icon is pressed, the display will be awakened. After a short time, it will go back to sleep. When in sleep mode, wake up the display to confirm ice maker is On/Off. Sleep mode can be turned off to have the display on full time (awake mode). When sleep mode is Off, the display will always be illuminated. To turn sleep mode On/Off, simultaneously press and hold “Crush” and “Light” icons for 5 seconds. Tone will confirm.

Awake Mode Display

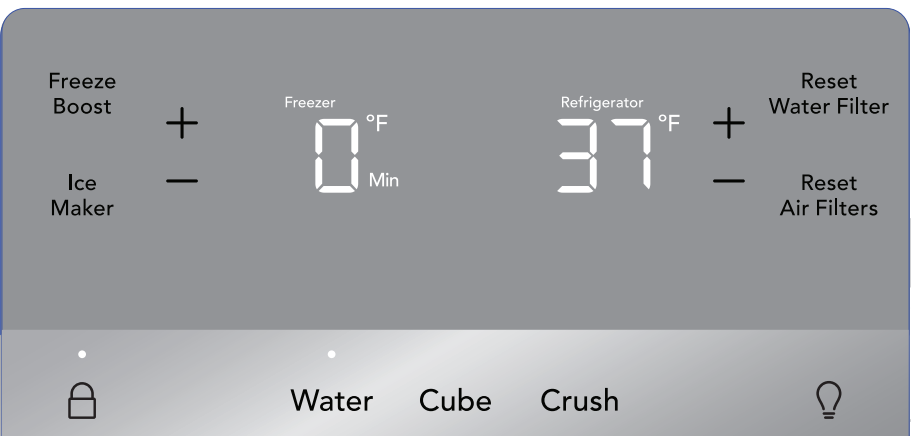

Awake Mode

To change from sleep mode (on) to awake mode (off), simultaneously press and hold “Crush” and “Light” icons for 5 seconds. Display will show the current temperature/ice maker status. Tone will confirm.

## External Water Dispenser Control Display

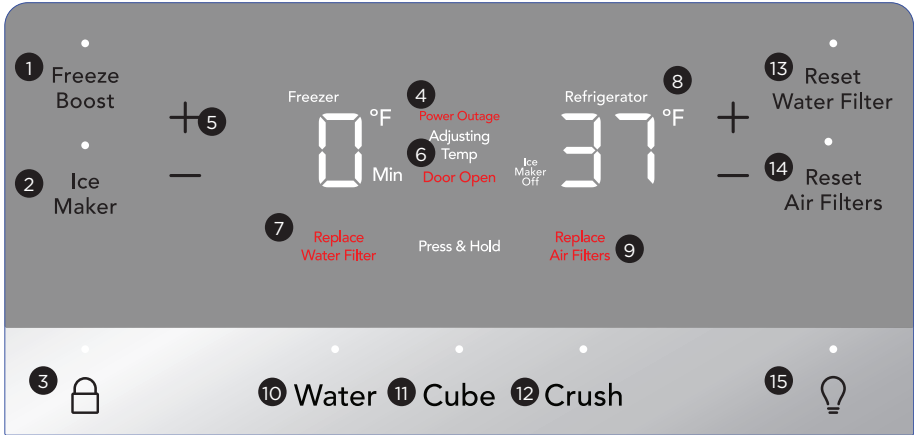
**1 Freeze Boost (on/off)**

Prior to grocery shopping, we recommend you activate **Freeze Boost** to lower the temperature and freeze food faster. **Freeze Boost** will remain active for up to 24 hours before automatically deactivating or manually exiting by pressing **Freeze Boost** to turn the function off. This will reset the freezer to the previous temperature setting.

**2 Ice Maker**

Press and hold for 3 seconds to turn ice maker on/off. When indicator is lit, ice maker is on. When indicator is not lit, ice maker is in the OFF state and will stop making ice. While off, ice dispensing can continue as long as there is ice in the bucket. When ice maker is off and ice is dispensing, indicator will blink.

**3** 

The lock button can be used to lock the display preventing it from being used in certain situations. Press and hold for 3 seconds to enable/disable. While in the locked state, no changes can be made to settings on the display. Dispensing ice and water will be disabled. The indicator will flash and an audible warning tone is played.

**4 Power Outage**

In the event of a power outage, the power outage alert will be illuminated once power has been restored and a tone will sound. Press any button to silence the tone.

**5 Adjusting Temp**

Illuminates when temperatures are changed on the display and will remain illuminated until the desired temperatures are reached inside the refrigerator and freezer. Press either the + or - to adjust to desired temperature setting.

**Freezer temp** - Control temperatures range from -6°F / -21°C to +6°F / -15°C.

**Refrigerator temp** - Control temperatures range from +34°F / +1°C to +44°F / +7°C. This unit is designed to operate at 37°F Refrigerator/0°F Freezer. Unit should stabilize temperatures within 24 hours of installation.

## External Water Dispenser Control Display

## Baseline Dispenser Display

- 6 Door Open**  
This alert indicates the door has been open for 5 minutes or more. The Door Open LED illuminates and the audible alert sounds until the door is closed. The audible alert can be turned off by pressing the Door Open key or by closing the door. If the door is open for 5 minutes, the interior light will turn off.
- 7 Replace Water Filter**  
Display illuminates every 6 months or when filter needs replacing. Replace the filter then press and hold **Reset Water Filter** button for 3 seconds to deactivate the warning on display. See **Replacing the Filter** for more information.
- 8 F/C**  
To toggle between Fahrenheit (°F) and Celsius (°C), simultaneously press and hold + and - for 5 seconds on refrigerator side of display.
- 9 Replace Air Filters**  
Display illuminates every 6 months or when filter needs replacing. Replace the filter and then press and hold **Reset Air Filters** button for 3 seconds to deactivate the warning on the display. See **Replacing the Filter** for more information.
- 10 Water**  
Press the Water key to select water. An indicator light will be illuminated above the active feature.
- 11 Cube**  
Press the Cube key to select cubed ice. An indicator light will be illuminated above the active feature.
- 12 Crush**  
Press the Crush key to select crushed ice. An indicator light will be illuminated above the active feature.
- 13 Reset Air Filters**  
Filter condition status is always displayed when the door is open. Press and hold button for three seconds to reset after changing the filter.

- 14 Reset Water Filter**  
Press and hold button for three seconds to reset after filter change.

- 15 Light**  
Toggles dispenser light On and Off.
- 

## Setting cooling temperatures (options may vary)

 **NOTE**

The recommended settings for a product installed in a kitchen is 37°F for the fresh food compartment and 0°F for the freezer.

 **IMPORTANT**

If your product has food freezing in the fresh food compartment, increase the temperature setting 1 or 2 degrees.

 **IMPORTANT**

If you place food within 1 inch in front of the air ports, there may be the chance of freezing food.

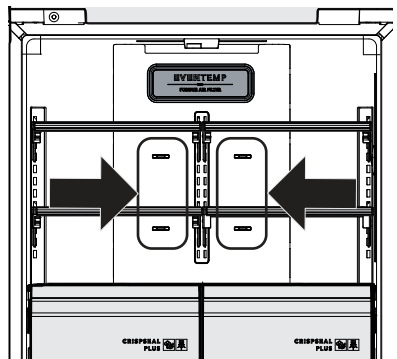

## External Water Dispenser Control Display

### Clear Alerts

#### Door Open

If the freezer or refrigerator doors are left open for five minutes or more, an alarm sounds and the door open indicator illuminates on the display. Close the door or press any key on the display to silence the alarm. The control panel will return to normal operations after the door is closed.

#### High Temp Alarm

An alarm sounds in the event of a high temperature condition. The control panel displays HI on whichever compartment the alarm is detected in and the alarm sounds every 10 seconds until acknowledged. Touch any key or open a door to silence the alarm.

#### Power Outage

In the event of a power outage, a tone sounds and the power outage alert illuminates once power has been restored. Press any key on the control panel to silence the alarm.

#### Flapper (Dispenser Models Only)

If the flapper (or ice chute door) is held open by a jammed ice cube when “Cube” or “Crush” is selected, an alarm sounds and the current selection blinks on the dispenser control. The alarm resets when the ice cube is removed.

### Sabbath Mode

The Sabbath Mode is a feature that disables portions of the refrigerator and its controls in accordance with observance of the weekly Sabbath and religious holidays within the Orthodox Jewish community.

Sabbath Mode is turned ON and OFF by simultaneously pressing and holding both the “FZ-” and “FF+” for 10 seconds. The display shows “Sb” while in Sabbath mode.

In the Sabbath Mode, the High Temp alarm is active for health reasons. For example, if the door is left ajar the High Temp alarm is activated. The refrigerator will function normally once the door is closed, without any violation of the Sabbath/Holidays. The High Temp alarm is permitted when cabinet temperature is outside the safe zone for 20 minutes. The alarm silences itself after 10 minutes while the High Temp icon stays lit until the Sabbath Mode is exited.



For further assistance, guidelines for proper usage and a complete list of models with the Sabbath feature, please visit the web at <http://www.star-k.org>.



#### NOTE

While in Sabbath Mode, neither the lights, dispenser, nor the control panel will work until Sabbath Mode is deactivated.

Refrigerator stays in Sabbath Mode after power failure recovery. It must be deactivated with the buttons on the control panel.



#### NOTE

Although you have entered the Sabbath Mode, the ice maker will complete the cycle it had already initiated. The ice cube compartment will remain cold and new ice cubes can be made with standard trays.



## Non-Dispenser Control Display Mode Views

Your display is equipped with a sleep and lock mode to prevent accidental changes to the unit settings during opening and closing of the doors. When both doors are closed, the display will be in sleep mode. When either door is first opened, the display will be in lock mode where all the current settings are visible but dimmed.

Pressing any button on the display will awake the display and a tone will be played. All settings will then be fully lit. Touch the display again to change any setting.

If there is no button pressed for 10 seconds while any door is open, the display will default back to lock mode.

Awake Mode View

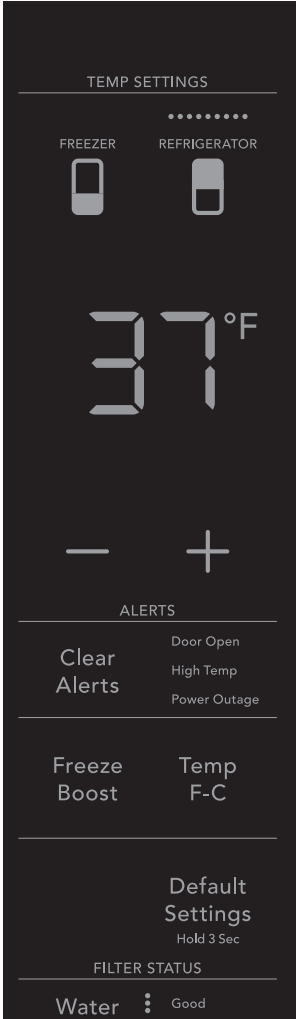

Lock Mode View

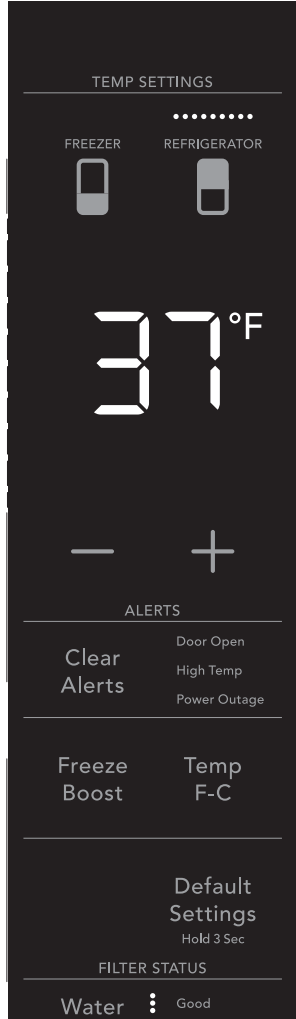

Sleep Mode View

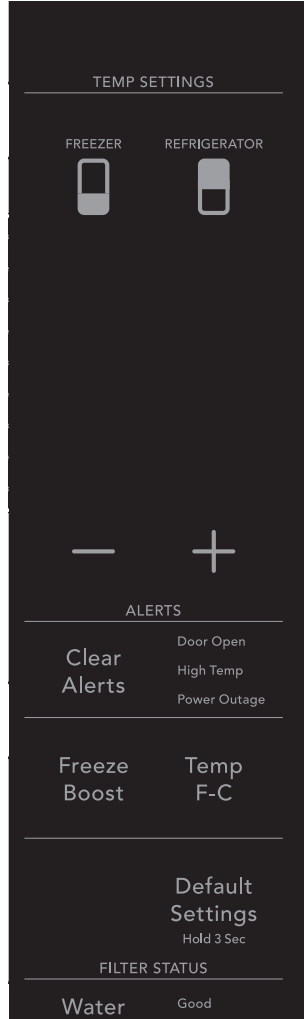

# 24 CONTROLS AND SETTINGS

## Non-Dispenser Control Display

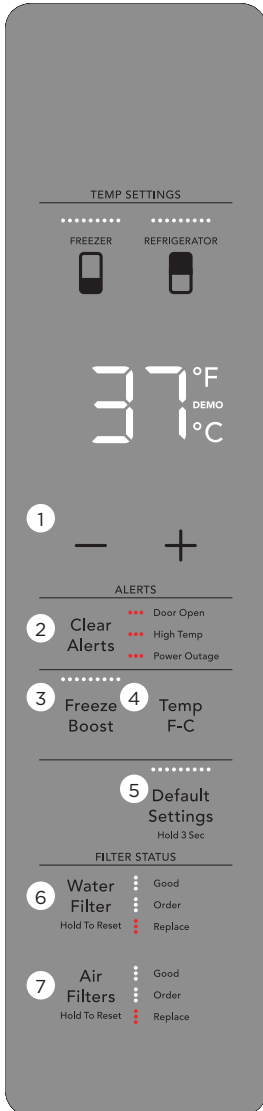

① **Change Temperature** Select Freezer or Refrigerator compartment to change temperature.

Select +/- buttons to set the temperature

Freezer -6 °F/-21 °C - control range: +6 °F/-15 °C

Refrigerator +34 °F/+1 °C - control range: +44 °F/+7 °C

② **Clear Alerts** Resets any active lit door open, high temp or power outage alarms on the control panel.

③ **Freeze Boost** Prior to grocery shopping, we recommend you activate Freeze Boost to lower the temperature and freeze food faster. Freeze Boost will remain active for up to 24 hours before automatically deactivating or manually exiting by pressing Freeze Boost to turn the function off. This will reset the freezer to the previous temperature setting.

④ **F/C** Touch to toggle display from Fahrenheit to Celsius.

⑤ **Default Settings** Press and hold for 3 seconds to reset to Factory settings.

⑥ **Water Filter** Press and hold to reset after filter has been replaced, status shown at right of button will reset to GOOD.

⑦ **Air Filters** Press and hold to reset after filter(s) has been replaced, status shown at right of button will reset to GOOD.

### NOTE

The recommended settings for a product installed in a kitchen is 37 °F for the fresh food compartment and 0 °F for the freezer.

### Setting cooling temperatures

Press the + or – indicator to adjust the temperature to the desired setting.

The temperature setting will begin to blink with the first touch. The display will time out after 10 seconds and return to the basic display.

## Non-Dispenser Control Display

### Clear Alerts

#### Door Open

If the freezer or refrigerator doors have been left open for five minutes or more, an alarm will sound and the door open indicator will illuminate on the display. Press “CLEAR ALERTS” to reset any system alarms.

#### High Temp Alarm

HIGH TEMP will illuminate next to clear alerts button. Alarm is played every 60 seconds. Press “CLEAR ALERTS” button to acknowledge the alarm. The highest temp value will be displayed when the alarm is first acknowledged.

#### Power Outage

In the event of a power outage, the power outage alert will be illuminated. Press “CLEAR ALERTS” to acknowledge the alarm. Other modes may be turned off until the alarm is acknowledged. While a power outage alert is displayed on the control panel, the unit will continue normal operation. The high temp alarm may also be illuminated until a safe operating range temperature has been reached.

### Sabbath Mode

The Sabbath Mode is a feature that disables portions of the refrigerator and its controls in accordance with observance of the weekly Sabbath and religious holidays within the Orthodox Jewish community.

Sabbath Mode is turned ON and OFF by simultaneously pressing and holding both the “-” and “Temp F-C” for five seconds. The display shows “Sb” while in Sabbath mode.

In the Sabbath Mode, the High Temp alarm is active for health reasons. For example, if the door is left ajar the High Temp alarm is activated. The refrigerator will function normally once the door is closed, without any violation of the Sabbath/Holidays. The High Temp alarm is permitted when cabinet temperature is outside the safe zone for 20 minutes. The alarm silences itself after 10 minutes while the High Temp icon stays lit until the Sabbath mode is exited.

#### NOTE

Food placed within 1 in. in front of air ports may cause food to freeze.

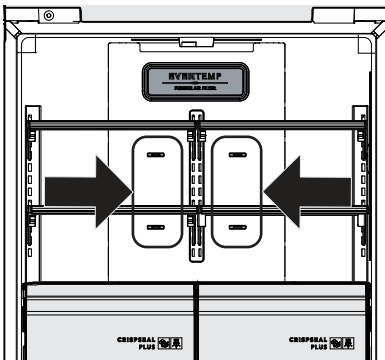

For further assistance, guidelines for proper usage and a complete list of models with the Sabbath feature, please visit the web at <http://www.star-k.org>.

#### NOTE

While in Sabbath Mode, neither the lights, dispenser, nor the control panel will work until Sabbath Mode is deactivated.

Refrigerator stays in Sabbath Mode after power failure recovery. It must be deactivated with the buttons on the control panel.

#### NOTE

Although you have entered the Sabbath Mode, the ice maker will complete the cycle it had already initiated. The ice cube compartment will remain cold and new ice cubes can be made with standard trays.

## Refrigerator Ice Maker (External Dispenser Models Only)

### Priming the water supply system

#### Using the dispenser after installation

Before making ice for the first time, be sure to prime the water supply system. Air in new plumbing lines can result in two or three empty ice maker cycles. Furthermore, if the system is not flushed, the first ice cubes may have discolored water or have an odd flavor.



#### CAUTION

For proper dispenser operation, recommended water supply pressure should fall between 30 psi and 100 psi. Excessive pressure may cause the system to malfunction.

1. Begin filling the system by pressing and holding a drinking glass against the water dispenser paddle.
2. Keep the glass in this position until water comes out of the dispenser. It may take about 1½ minutes.
3. Continue dispensing water for about four minutes to flush the system and plumbing connections of any impurities (stopping to empty the glass as necessary).

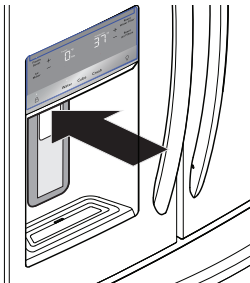

Dispenser  
(varies by  
model)



#### NOTE

The water dispenser has a built-in device that shuts off the water flow after three minutes of continuous use. To reset this shutoff device, simply release the dispenser paddle.



#### NOTE

Dispensed water is not chilled. For colder water, add ice to cup or container before dispensing water.

### Ice maker operation & care

After the refrigerator is installed properly and has cooled for several hours, the ice maker can produce ice within 24 hours. The ice maker will fill the ice bin from the rear. You must dispense some ice to force the ice forward in the bin. This will allow the bin to fill completely.

### Ice Maker and Storage Bin Capacity

In a Standard Depth model, the refrigerator ice maker should produce 3.0 to 3.4 pounds of ice per 24 hours. In a Counter Depth model, the refrigerator ice maker should produce 2.7 to 3.2 pounds of ice per 24 hours.

In a Standard Depth model, the refrigerator ice bin will hold around 5 pounds of ice. In a Counter Depth model, the refrigerator ice bin will hold around 3.7 pounds of ice.

## Refrigerator Ice Maker (External Dispenser Models Only)

### Turning the refrigerator ice maker on and off

Ice production is controlled by the ice maker's On/Off feature on the control panel. Pressing the On/Off feature turns the ice maker on & off.



#### IMPORTANT

Turning off the ice maker simply disables ice making. You will still be able to dispense existing ice, and you will still be able to dispense water.



#### NOTE

The ice maker also has a built-in plastic signal arm that automatically stops ice production when the ice bin is full. This signal arm should not be used to manually stop the ice maker.



#### IMPORTANT

Your ice maker is turned on at the factory so it can work as soon as you install your refrigerator. If you cannot connect a water supply, set the ice maker's On/Off feature to Off; otherwise, the ice maker's fill valve may make a loud chattering noise when it attempts to operate without water.



#### IMPORTANT

On occasion, unusually small ice cubes may be noticed in the bucket or in dispensed ice. This could occur in normal operation of the ice maker. If you start seeing these more frequently, it may be an indication of low water pressure or the water filter needs to be replaced. As the water filter nears the end of its useful life and becomes clogged with particles, less water is delivered to the ice maker during each cycle. Remember, if it's been six months or longer since you last changed your water filter, replace the water filter with a new one. Poor quality household water may require the filter to be changed more frequently.

### Ice maker/dispenser tips

- If your refrigerator is not connected to a water supply or the water supply is turned off, turn off the ice maker as described in the previous section.
- The following sounds are normal when the ice maker is operating:
  - Motor running
  - Ice dropping into ice bin
  - Water valve opening or closing
  - Running water
- If you need a large quantity of ice at one time, it is best to get cubes directly from the ice bin.
- Ice cubes stored too long may develop an odd flavor. Empty the ice bin as explained below.
- When dispensing cubed ice, it is normal to have a small quantity of little pieces along with the whole cubes.
- To avoid splashing, dispense ice into your container before adding liquids.
- It is normal for ice to fill to the top of the ice bin.



#### CAUTION

If the water supply to your refrigerator is softened, be sure the softener is properly maintained. Chemicals from a water softener can damage the ice maker.

### Refrigerator Ice Maker (External Dispenser Models Only)

#### Cleaning the ice maker

Clean the ice maker and ice bin at regular intervals, especially prior to vacation or moving.

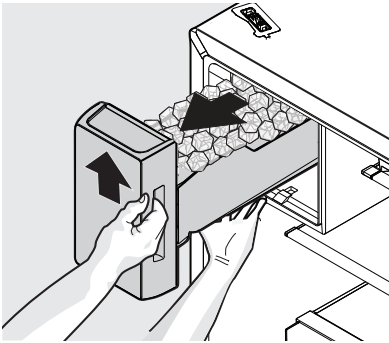

Removing Ice Bin

1. Turn off the ice maker.
2. Lift the ice bin upward then pull straight out to remove.
3. Empty and carefully clean the ice bin with mild detergent. Do not use harsh or abrasive cleaners. Rinse with clean water.
4. Allow the ice bin to dry completely before replacing in the freezer.
5. Replace the ice bin. Turn the ice maker on.

#### Remove and empty the ice bin if:

- An extended power failure (one hour or longer) causes ice cubes in the ice bin to melt and refreeze together after power is restored, jamming the dispenser mechanism.
- You do not use the ice dispenser frequently. Ice cubes will freeze together in the bin, jamming the dispenser mechanism.



#### CAUTION

NEVER use an ice pick or similar sharp instrument to break up the ice. This could damage the ice bin and dispenser mechanism.

To loosen stuck ice, use warm water. Before replacing the ice bin, make sure it is completely dry.



#### IMPORTANT

When removing or replacing the ice bin, avoid rotating the auger in the ice bin. If the auger is accidentally rotated, you must realign the auger by turning it in 45 degree turns (see below) until the ice bin fits into place with the drive mechanism. If the auger is not properly aligned when replacing the ice bin, the refrigerator will not dispense ice. The refrigerator door also may not close properly causing warm air to leak into the refrigerator compartment.

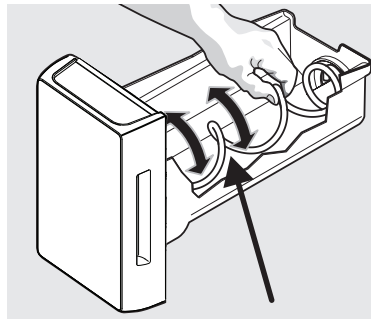

Adjusting Ice Bin Auger

**Freezer Ice Maker (Non-Dispenser Models Only)****Freezer Ice Maker****Ordering Optional Freezer Ice Maker**

Order optional freezer ice maker online at [www.frigidaire.com/store](http://www.frigidaire.com/store), by calling 1-800-374-4432 or through the dealer from which the refrigerator was purchased.

**Ice Maker Operation & Care**

After the refrigerator is installed properly, the ice maker can produce ice within 24 hours. When using the ice maker for the first time, and in order for it to work properly, it is necessary to clear air from the water tubing and the filter. Furthermore, if the system is not flushed, the first ice cubes may be discolored or have an odd flavor. Once the ice maker begins making ice, allow the bin to fill completely, then discard the first FULL bin of ice.

**Ice Maker and Storage Bin Capacity**

This ice maker should produce between 2 and 2.5 pounds of ice per 24 hours depending on usage conditions. For a Standard Depth unit, the ice bin should hold around 12 pounds of ice. For a Counter Depth unit, the ice bin should hold around 9 pounds of ice.

**NOTE**

The ice maker will only produce the advertised production rate if the product is set at 0°F.

**NOTE**

The Freezer Ice maker fills from the back left-hand corner of the bin. Moving the ice to the edges of the bin allows the bin to fill completely.

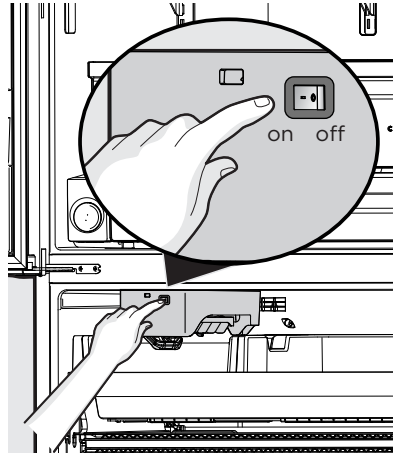
**Turning the ice maker on and off**

Press power button to turn Ice Maker on (button will not illuminate).

**Ice maker tips**

- The following sounds are normal when the ice maker is operating:
  - Motor running
  - Ice dropping into ice bin
  - Water valve opening or closing
  - Running water
- Ice cubes stored too long may develop an odd flavor. Empty the ice bin as explained below.

**CAUTION**

If the water supply to your refrigerator is softened, be sure the softener is properly maintained. Chemicals from a water softener can damage the ice maker.

### Cleaning the ice maker bin

Clean the ice maker and ice bin at regular intervals, especially prior to vacation or moving.

1. Turn off the ice maker.
2. Remove the ice bin.
3. Empty and carefully clean the ice bin with mild detergent. Do not use harsh or abrasive cleaners. Rinse with clean water.
4. Allow the ice bin to dry completely before replacing in the freezer.
5. Replace the ice bin. Turn the ice maker on.

Remove and empty the ice bin if an extended power failure (one hour or longer) causes ice cubes in the ice bin to melt and refreeze together after power is restored.



#### CAUTION

NEVER use an ice pick or similar sharp instrument to break up the ice. This could damage the ice bin.

To loosen stuck ice, use warm water. Before replacing the ice bin, make sure it is completely dry.

---



## Shelves



### CAUTION

To avoid personal injury or property damage, handle tempered glass shelves carefully. Shelves may break suddenly if nicked, scratched, or exposed to sudden temperature change. Allow the glass shelves to stabilize to room temperature before cleaning. Do not wash in dishwasher.

You can easily adjust shelf positions in the refrigerator compartments to suit your needs. The shelves have mounting brackets that attach to slotted supports at the rear of each compartment.

### Change the Position of a Shelf

1. Remove all food from shelf.
2. Lift the front edge up and pull the shelf out.

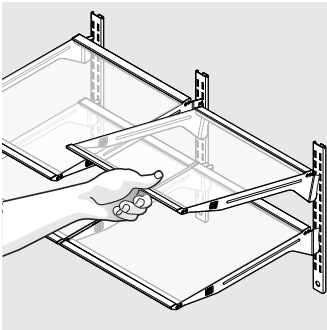

3. Replace by inserting the mounting bracket hooks into the desired support slots.
4. Lower the shelf and lock into position.

## Reposition the Air Seal

### For glass shelves:

1. Remove air seal by pushing seal straight back.
2. Position the air seal towards the outside edge of the shelf to avoid the air tower when shelf is pushed back into place.
3. Install seal by sliding the open channel end of the seal onto back edge of shelf until seal sits snug on back of shelf and flap sits at about a 10 degree angle from shelf surface.



### IMPORTANT

Be aware of the air seal located at the rear of the shelf. Shelves located on the left side should have the air seal mounted on the far left side. Shelves located on the right side should have the air seal mounted on the far right side. This is to ensure there is no interference with the large air tower on the back wall of the cabinet. This also applies to the crisper shelves.

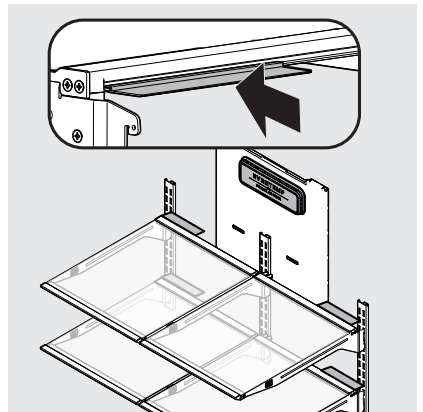

# 32 STORAGE FEATURES

## Drawers

Your refrigerator includes a variety of storage drawers.

## Crispers

Crisper drawers are designed for storing fruits, vegetables, and other fresh produce.

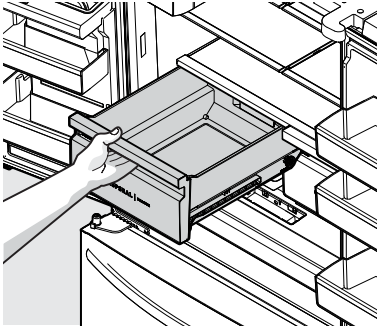

Opening Crisper Drawer

## Crisper Humidity Control

Crisper drawers include a sliding control for adjusting the humidity inside the crisper. Leafy vegetables keep best when stored with the Humidity Control set on Higher Humidity. Fresh fruits keep best when stored with the Humidity Control set on Lower Humidity.

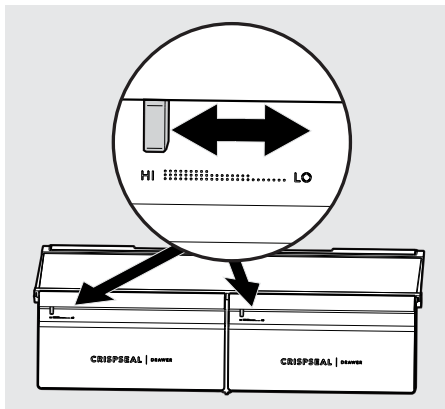

## To remove the Crisper Drawer with PureAir Produce Keeper™ for cleaning:

1. Pull the drawer out until it stops.
2. Lift the front slightly and remove the drawer.

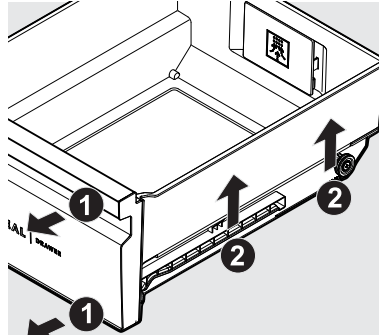

Removing Crisper Drawer



## CAUTION

Remove the produce keeper prior to washing the crisper drawer.

## To replace the Crisper Drawers with PureAir Produce Keeper™ after cleaning:

1. Place the crisper drawer on top of the deli cover and tilt upwards slightly.



## NOTE

Gasket should be on the outside wall of the crisper after being removed and re-installed into the unit.

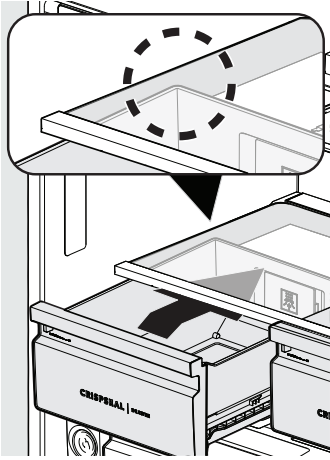

2. Push the crisper straight once the bottom rollers clear the front deli crisper support rollers.

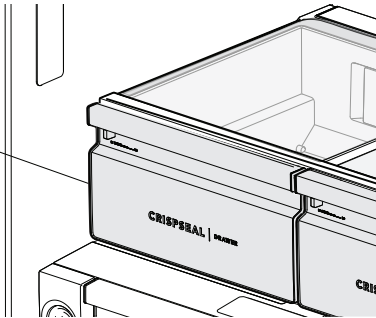

## Deli drawer

Ideal for storage of deli meats, cheese, and beverages.

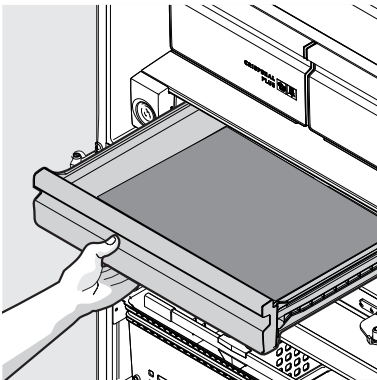

## Doors

### Storage bins (varies by model)

The doors to your refrigerator compartment use a system of modular storage bins. All of these bins are removable for easy cleaning. Some of them have fixed positions, while others can be adjusted to your needs.

Door bins are ideal for storing jars, bottles, cans, and large drink containers. They also enable quick selection of frequently used items.

### To change the position of an adjustable door bin:

1. Remove all food from door bin.
2. Grip the bin firmly with both hands and lift it upward.
3. Remove the bin.
4. Place the bin just above desired position.
5. Lower the bin onto supports until locked in place.
6. Place bin liner into bin.

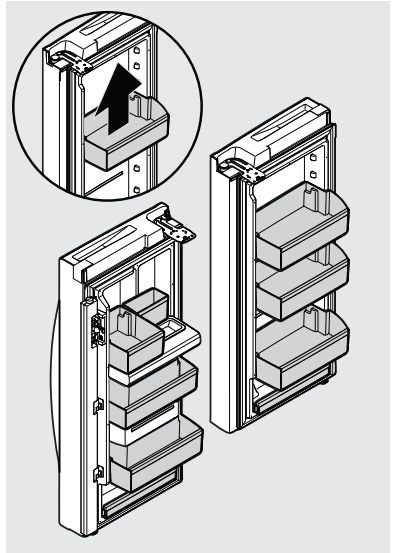

Adjustable Door Bins

# 34 STORAGE FEATURES

## Freezer Accessories

Your freezer has baskets and dividers that can be adjusted to your needs.

### Remove Upper Freezer Basket

1. Open freezer drawer fully.
2. Extend upper freezer drawer all the way out from the cabinet.

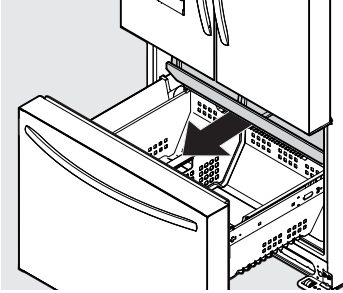

3. Push inward slightly on the basket tabs to release the upper basket from the slide assemblies (1 per side, in front).

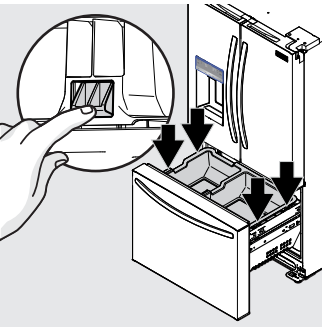

4. Lift basket up and out of freezer compartment.

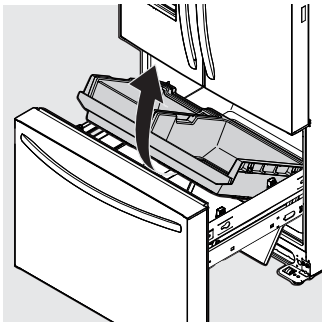

## Upper Freezer Basket Replacement

1. Open Freezer drawer completely.

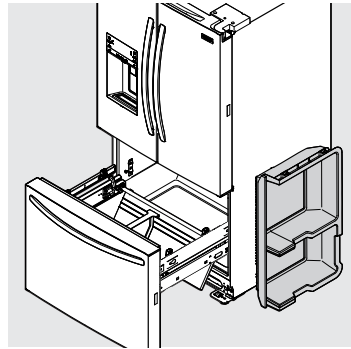

2. Pull both upper slides out of the freezer compartment, extending them fully.
3. Take upper basket assembly and snap basket back into the docks on the slide assemblies. Perform this on one side at a time as slides will move freely during installation.
4. Once basket is fully seated on the upper slide assemblies, push basket back into freezer compartment.

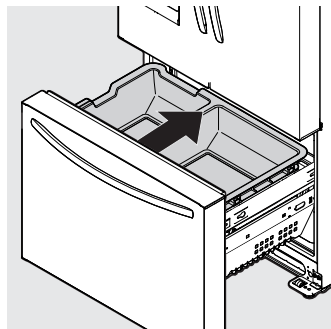

5. Close freezer drawer completely.

### To Remove Lower Freezer Basket:

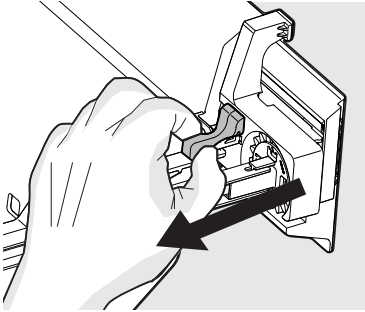

1. Open freezer compartment completely.
2. Locate basket clips in the rear corners of the basket and pull them out to remove.
3. Lift the basket up and remove.

Reverse the steps to reinstall the lower freezer basket.

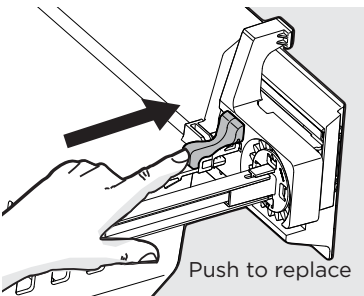

### Lower basket Divider

Grab hand hold on lower divider and pull up slightly to slide to next position. (The divider cannot be removed.)

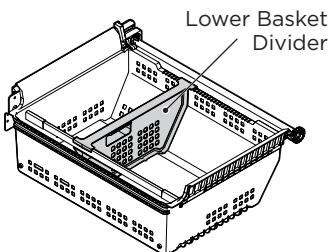

**Ideas for storing foods****Fresh food storage**

- Keep the fresh food compartment between 34°F and 40°F with an optimum temperature of 37°F.
- Avoid overcrowding the refrigerator shelves, which reduces air circulation and causes uneven cooling.
- Avoid placing food in front of air ports. (See Controls Section for illustration.)

**Fruits and vegetables**

- Store fruits and vegetables in crisper drawers, where trapped moisture helps preserve food quality for longer time periods.
- Wash items and remove excess water.
- Wrap any items that have strong odors or high moisture content.

**Meat**

- Wrap raw meat and poultry separately and securely to prevent leaks and contamination of other foods or surfaces.
- Use the deli drawer to store meat/poultry for short-term storage. Any meat to be kept longer than two days should be frozen.

**Frozen food storage**

- Keep the freezer compartment at 0°F or lower.
- A freezer operates most efficiently when it is at least  $\frac{2}{3}$  full.

**Packaging foods for freezing**

- To minimize food dehydration and quality deterioration, use aluminum foil, freezer wrap, freezer bags, or airtight containers. Force as much air out of the packages as possible and seal them tightly. Trapped air can cause food to dry out, change color, and develop an off-flavor (freezer burn).
- Wrap fresh meats and poultry with suitable freezer wrap prior to freezing.
- Do not refreeze meat that has completely thawed.

**Loading the freezer**

- Prior to grocery shopping, activate Freeze Boost so that on your return you can ensure your newly

purchased food designated for the freezer will be preserved as quickly as possible.

- Activating Freeze Boost also will help your freezer more efficiently maintain the selected temperature after placing new purchases with pre-existing frozen foods.
- Avoid adding too much warm food to the freezer at one time. This overloads the freezer, slows the rate of freezing, and can raise the temperature of frozen foods.
- Leave a space between packages, so cold air can circulate freely, allowing food to freeze as quickly as possible.

**Ideas for saving energy****Installation**

- Locate the refrigerator in the coolest part of the room, out of direct sunlight, and away from heating ducts or registers.
- Do not place the refrigerator next to heat-producing appliances such as a range, oven, or dishwasher. If this is not possible, a section of cabinetry or an added layer of insulation between the two appliances will help the refrigerator operate more efficiently.
- Level the refrigerator so that the doors close tightly.

**Temperature settings**

- Refer to the “Controls” section for procedures on temperature settings.

**Food storage**

- Avoid overcrowding the refrigerator or blocking cold air vents. Doing so causes the refrigerator to run longer and use more energy.
  - Cover foods and wipe containers dry before placing them in the refrigerator. This cuts down on moisture build-up inside the unit.
  - Organize the refrigerator to reduce door openings. Remove as many items as needed at one time and close the door as soon as possible.
  - Do not place a hot container directly on a cold shelf. Remember, such an extreme temperature change may damage the glass.
-



## NOTE

Energy efficient foam in your refrigerator is not a sound insulator.



## NOTE

During automatic defrost cycle, a red glow in the back wall vents of your freezer compartment is normal.

## Understanding the sounds you may hear

Your new, high-efficiency refrigerator may introduce unfamiliar sounds. These sounds normally indicate your refrigerator is operating correctly. Some surfaces on floors, walls, and kitchen cabinets may make these sounds more noticeable.

The following is a list of major components in your refrigerator and the sounds they can cause:

- A. Evaporator** Refrigerant through the evaporator may create a boiling or gurgling sound.
- B. Evaporator fan** You may hear air being forced through the refrigerator by the evaporator fan.
- C. Defrost heater** During defrost cycles, water dripping onto the defrost heater may cause a hissing or sizzling sound. After defrosting, a popping sound may occur.
- D. Automatic ice maker** When ice has been produced, you will hear ice cubes falling into the ice bin. Ice maker fan, water valve activation, and refrigerant gas fluid may create sounds from its operation.
- E. Electronic control & automatic defrost control** These parts can produce a snapping or clicking sound when turning the cooling system on and off.
- F. Condenser fan** You may hear air being forced through the condenser.
- G. Compressor** Modern, high-efficiency compressors run much faster than older models. The compressor may have a high-pitched hum or pulsating sound.
- H. Water valve** Makes a buzzing sound each time it opens to fill the ice maker.
- I. Drain pan** (not removable) You may hear water dripping into the drain pan during the defrost cycle.
- J. Condenser** May create minimal sounds from forced air.
- K. Motorized damper** May produce a light humming during operation.
- L. Ice dispensing paddle** When dispensing ice, you will hear a snapping, clicking, or popping sound.

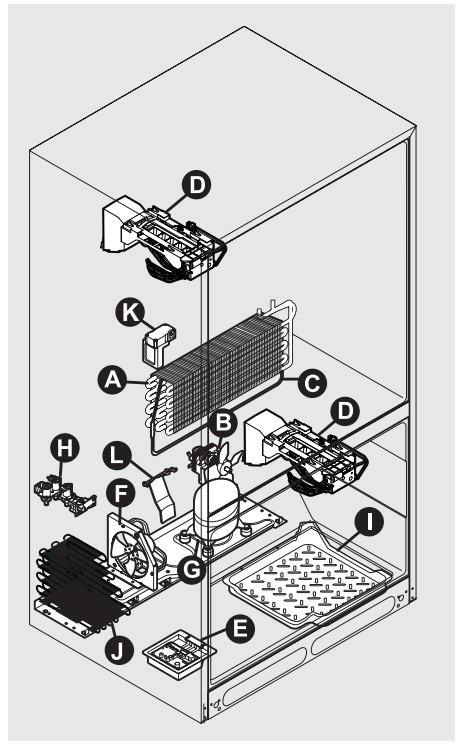

Features vary by model

# 38 FILTER REPLACEMENT

## Air filter

The air filter is located at the top of the air tower.

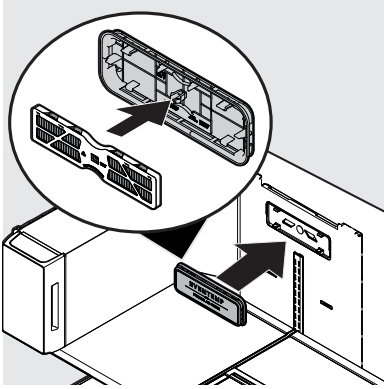

## Replacing your PureAir™ AF-2 Air Filter

To ensure optimal filtering of refrigerator odors, you should change the air filter every six months (the filter status light on the main controls prompts you to replace the filter after six months).

### To remove and replace the air filter:

1. Place fingers on top of air cover and gently pull towards front of unit releasing the top snaps on the cover from the air tower.
2. Lift bottom snaps up and out of air tower assembly to disengage and remove front cover.
3. Replace air filter by snapping filter into snaps on air filter cover.
4. Installation of front cover is reverse of removal.
5. To reset Air Filter status, refer to instructions under "Controls Section".

## Ordering replacement filters

Order new filters by calling 877-808-4195, online at [www.frigidaire.com/store](http://www.frigidaire.com/store), or through the dealer where you bought your refrigerator. You may want to consider ordering extra filters when you first install your refrigerator.

Air Filter Replacement cartridge, part # **FRGPAAF2**

## Locating the Water Filter

Your refrigerator is equipped with water filtering system. The water filter system filters all dispensed drinking water, as well as the water used to produce ice.

The water filter is located at the left side of the Deli Drawer.

## PurePour™ Water Filter

Keep safe, great-tasting water flowing with a **PurePour™** water filter. Using a **PurePour™** water filter:

- **Makes Safe Water Second Nature**  
**PurePour™** water filters are certified to reduce contaminants\* and keep great-tasting water flowing for you and your family.
- **Produces Purity You Can Trust**  
Know for certain your **PurePour™** water filter is a protector. Counterfeits and knockoffs put your refrigerator and health at risk. Frigidaire Genuine Filters are the smarter, safer choice.
- **Every Drop Gives Back**  
Partnered on sustainability efforts, the use of a **PurePour™** water filter helps cut back on the cost and use of plastic used to produce and package bottled water

\*For the complete list, please see Performance DataSheet on [Frigidaire.com](http://Frigidaire.com)



**Replacing the Water Filter**

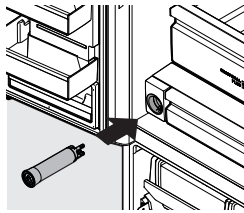

The water filter is located at the bottom left of the refrigerator compartment next to the Deli Drawer. In general, you should change the water filter every 6 months to ensure the highest possible water quality. **Water Filter Status** on the user interface prompts you to replace the filter after a standard amount of water (125 gal/453 L for **PurePour™**) has flowed through the system.

If you have not used your refrigerator for a period of time (during moving for example), change the filter before reinstalling the refrigerator.

**Ordering Replacement Filters**

To order your replacement filters, please visit our online store at [frigidaire.com](http://frigidaire.com), by calling toll-free at 1 (800) 372-4432, or by visiting the dealer where you purchased your refrigerator. Frigidaire recommends that you order extra filters when you first install your refrigerator, and that you replace your filters at least once every 6 months.

Here are the product numbers to request when ordering:

**PurePour™** Water Filter PWF-1  
Part# **FPPWFU01™**



**NOTE**

When you order your replacement filter, please reorder the same filter type currently in your refrigerator.

**More about your Advanced Water Filter**



The **PurePour™** ice and water filter system is tested and certified to NSF/ANSI Standards 42, 53, 401 and CSA B483.1 for the reduction of claims specified on the performance data sheet. Visit [frigidaire.com](http://frigidaire.com) for more information.

Do not use with water that is microbiologically unsafe or of unknown quality without adequate disinfection before or after the system. Use systems certified for cyst reduction on disinfected waters that may contain filterable cysts.

**Test & certification results:**

- Rated Capacity - 125 gal/453 L for **PurePour™** and ice and water filter
- Rated service flow - .50 gal/min.
- Operating Temp.: Min. 33°F, Max. 100°F
- Maximum Rated Pressure - 100 lbs/in.<sup>2</sup>
- Recommended Minimum Operating Pressure: 30 lbs/in.<sup>2</sup>

**Replacing your PurePour™ water filter**

It is not necessary to turn the water supply off to change the filter. Be ready to wipe up any small amounts of water released during the filter replacement.

1. Turn **Off** the ice maker(s).
2. Remove the filter by pushing on the end/face of the filter.
3. Slide the old water filter cartridge straight out of the housing and discard it.
4. Unpackage the new filter cartridge. Using the alignment guide, slide it gently into the filter housing until it stops against the snap-in connector at the back of the housing.

# 40 FILTER REPLACEMENT

5. Push firmly until the cartridge snaps into place (you should hear a click as the cartridge engages the snap-in connector).
6. Press a drinking glass against the water dispenser while checking for any leaks at the filter housing. Any spurts and sputters that occur as the system purges air out of the dispenser system are normal.
7. After filling one glass of water, continue flushing the system for about **4 minutes**.
8. Turn **On** the ice maker(s).
9. Press and hold the **Water Filter** reset button on the Ice & Water Dispenser control panel for 3 seconds. When the display changes from red to green, the status has been reset.

## NOTE

PureAir Produce Keeper™ accessories are optional and may be installed in most models at any time. Visit [Frigidaire.com](http://Frigidaire.com) for information about PureAir Produce Keeper™ PK-1 accessories.

Part # FRPAPKRF.

## PureAir Produce Keeper™

Keep fruits and vegetables fresher longer with **PureAir Produce Keeper™**. Our produce keeper absorbs ethylene gas, the natural gas that causes produce to ripen quicker. Reduce food waste, save money and enjoy fresh-tasting produce with a longer storage life.

### Ordering Replacement Filters

To order your replacement filters, please visit our online store at [frigidaire.com](http://frigidaire.com), by calling toll-free at 1 (800) 372-4432, or by visiting the dealer where you purchased your refrigerator. Frigidaire recommends that you replace your filters at least once every 6 months.

Here are the product numbers to request when ordering:

**PureAir Produce Keeper™ PK-1**

Part # **FRPAPKRF**.

## Installing the *PureAir Produce Keeper™*:

1. Remove the plastic wrapper. Insert unopened packet into the holder in the Crisper Drawer.
2. For optimal results, replace the refill every 6 months along with your air filter.

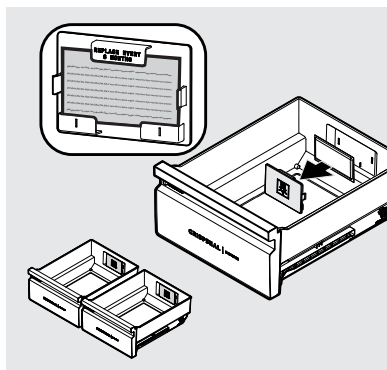
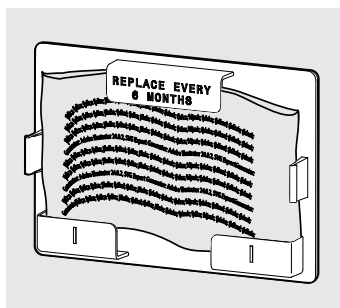

## CAUTION

**DO NOT OPEN.** Contents may irritate eyes or skin. Keep out of reach of children.

**FIRST AID:** Contains potassium permanganate. In case of contact with eyes or skin, rinse immediately with water.

**DO NOT EAT:** If swallowed, seek medical treatment immediately.

## Protecting your investment

Keeping your refrigerator clean maintains its appearance and prevents odor build-up.



### NOTE

Do not use abrasive cleaners such as window sprays, scouring cleansers, flammable fluids, cleaning waxes, concentrated detergents, bleaches, or cleansers containing petroleum products on plastic parts, interior doors, gaskets, or cabinet liners. Do not use paper towels, scouring pads, or other abrasive cleaning materials.

Wipe up any spills immediately and clean the freezer and fresh food compartments at least twice a year.

- Never use metallic scouring pads, brushes, abrasive cleaners, or strong alkaline solutions on any surface.
- Never use CHLORIDE or cleaners with bleach to clean stainless steel.



### NOTE

If you set your temperature controls to turn off cooling, power to lights and other electrical components will continue until you unplug the power cord from the wall outlet.

- Do not wash any removable parts in a dishwasher.
- Always unplug the electrical power cord from the wall outlet before cleaning.
- Remove adhesive labels by hand. Do not use razor blades or other sharp instruments which can scratch the appliance surface.
- Do not remove the serial plate. Removal of your serial plate voids your warranty.
- Before moving your refrigerator, raise the anti-tip brackets so the rollers will work correctly. This will prevent the floor from being damaged.

Refer to the guide on the next page for details on caring and cleaning specific areas of your refrigerator.



### CAUTION

- Pull the refrigerator straight out to move it. Shifting it from side to side may damage flooring. Be careful not to move the refrigerator beyond the plumbing connections.
- Damp objects stick to cold metal surfaces. Do not touch refrigerated surfaces with wet or damp hands.



### IMPORTANT

If you store or move your refrigerator in freezing temperatures, be sure to completely drain the water supply system. Failure to do so could result in water leaks when the refrigerator is put back into service. Contact a service representative to perform this operation.

# 42 CARE & CLEANING

## Vacation and moving tips

### Occasion Tips

- Short Vacations**
- Leave refrigerator operating during vacations of three weeks or less.
  - Use all perishable items from refrigerator compartment.
  - Turn automatic ice maker off and empty ice bucket, even if you will only be gone a few days.

- Long Vacations**
- Remove all food and ice if you will be gone one month or more.
  - Turn the cooling system off (see “Controls” section for location of On/Off button) and disconnect power cord.
  - Turn water supply valve to closed position.
  - Clean interior thoroughly.
  - Leave both doors open to prevent odors and mold build-up. Block doors open if necessary.

- Moving**
- Unplug unit
  - Remove all food and ice.
  - Recommend use of a handcart, load from the side.
  - Adjust rollers all the way up to protect them during sliding or moving.
  - Pad cabinet to avoid scratching surface.

### Care & Cleaning Tips

Part	What To Use	Tips and Precautions
<b>Interior &amp; Door Liners</b>	<ul style="list-style-type: none"> <li>• Soap and water</li> <li>• Baking soda and water</li> </ul>	Use two tablespoons of baking soda in one quart of warm water. <b>Be sure to wring excess water out of sponge or cloth before cleaning around controls, light bulb or any electrical part.</b>
<b>Door Gaskets</b>	<ul style="list-style-type: none"> <li>• Soap and water</li> </ul>	Wipe gaskets with a clean soft cloth.
<b>Drawers &amp; Bins</b>	<ul style="list-style-type: none"> <li>• Soap and water</li> </ul>	Use a soft cloth to clean drawer runners and tracks.
<b>Glass Shelves</b>	<ul style="list-style-type: none"> <li>• Soap and water</li> <li>• Glass cleaner</li> <li>• Mild liquid sprays</li> </ul>	Allow glass to warm to room temperature before immersing in warm water.
<b>Toe Grille</b>	<ul style="list-style-type: none"> <li>• Soap and water</li> <li>• Mild liquid sprays</li> <li>• Vacuum attachment</li> </ul>	Vacuum dust from front of toe grille. Remove toe grille (see Installation Instructions). Vacuum backside, wipe with sudsy cloth or sponge. Rinse and dry.
<b>Exterior &amp; Handles</b>	<ul style="list-style-type: none"> <li>• Soap and water</li> <li>• Non Abrasive Glass Cleaner</li> </ul>	Do not use commercial household cleaners containing ammonia, bleach or alcohol to clean handles. Use a soft cloth to clean smooth handles. <b>DO NOT use a dry cloth to clean smooth doors.</b>

Part	What To Use	Tips and Precautions
<b>Exterior &amp; Handles (Stainless Steel Models Only)</b>	<ul style="list-style-type: none"> <li>• Soap and water</li> <li>• Stainless Steel Cleaners</li> </ul>	<p><b>Never use CHLORIDE or cleaners with bleach to clean stainless steel.</b></p> <p>Clean stainless steel front and handles with non-abrasive soapy water and a dishcloth. Rinse with clean water and a soft cloth. Use a non-abrasive stainless steel cleaner. These cleaners can be purchased at most home improvement or major department stores. Always follow manufacturer’s instructions. Do not use household cleaners containing ammonia or bleach.</p> <p><b>NOTE: Always clean, wipe and dry with the grain to prevent scratching.</b> Wash the rest of the cabinet with warm water and mild liquid detergent. Rinse well, and wipe dry with a clean soft cloth.</p>

Let us help you troubleshoot your concern! This section will help you with common issues. If you need us, visit our website, chat with an agent, or call us. We may be able to help you avoid a service visit. If you do need service, we can get that started for you!

**1-800-374-4432 (United States)**  
**Frigidaire.com**

**1-800-265-8352 (Canada)**  
**Frigidaire.ca**

<b>Concern</b>	<b>Potential Cause</b>	<b>Common Solution</b>
<b>Automatic Ice Maker</b>		
Ice maker is not making any ice.	<ul style="list-style-type: none"> <li>• Ice maker is turned off.</li>   <li>• Refrigerator is not connected to water line or water valve is not open.</li>   <li>• The water supply line is kinked.</li>   <li>• The water filter is not seated properly.</li>   <li>• The water filter may be clogged with foreign material.</li> </ul>	<ul style="list-style-type: none"> <li>• Turn on ice maker. For the refrigerator ice maker, press and hold the Ice Maker On-Off button on your display. For the freezer ice maker, turn the ice maker on by pressing the toggle switch on the (-) side.</li>   <li>• Connect the unit to the household water supply and ensure the water valve is open.</li>   <li>• Ensure that the supply line does not kink when the refrigerator is pushed into place against the wall.</li>   <li>• Remove and re-install the water filter. Be sure to seat it fully into the locked position.</li>   <li>• If water dispenses slowly or not at all, or if the filter is six months old or older, it should be replaced.</li> </ul>

# 44 TROUBLESHOOTING

Concern	Potential Cause	Common Solution
<b>Automatic Ice Maker (Cont'd)</b>		
Ice maker is not making enough ice.	<ul style="list-style-type: none"> <li>• Ice maker is producing less ice than you expect.</li> <li>• The water filter may be clogged with foreign material.</li> <li>• Saddle valve on cold water pipe is clogged or restricted by foreign material.</li> <li>• Heavy traffic, opening or closing of the doors excessively.</li> <li>• Freezer control is set too warm (freezer ice maker).</li> <li>• Water pressure is extremely low. Cut-off and cut-on pressures are too low (well systems only).</li> <li>• Reverse osmosis system is in regenerative phase.</li> </ul>	<ul style="list-style-type: none"> <li>• In a Standard Depth model, the refrigerator ice maker should produce 3.0 to 3.4 pounds of ice per 24 hours. In a Counter Depth model, the refrigerator ice maker should produce 2.7 to 3.2 pounds of ice per 24 hours.</li> <li>• In a Standard Depth model, the refrigerator ice bin will hold around 5 pounds of ice. In a Counter Depth model, the refrigerator ice bin will hold around 3.7 pounds of ice.</li> <li>• If water dispenses slower than normal, or if the filter is six months old or older, it should be replaced.</li> <li>• Ensure that the supply line does not kink when the refrigerator is pushed into place against the wall.</li> <li>• Turn off household water line valve. Remove valve. Clean valve. Replace valve if necessary.</li> <li>• Set freezer control to colder setting to improve performance of the ice maker (freezer ice maker). Allow 24 hours for temperature to stabilize.</li> <li>• Have someone turn up the cut-off and cut-on pressure on the water pump system (well systems only).</li> <li>• It is normal for a reverse osmosis system to be below 20 psi during the regenerative phase.</li> </ul>
Freezer ice maker will not stop making ice (select models).	<ul style="list-style-type: none"> <li>• Ice maker bail arm is being held down by a package in the freezer that has fallen against ice maker.</li> <li>• Ice cubes are located in once spot inside the freezer ice bin</li> </ul>	<ul style="list-style-type: none"> <li>• Move any item or frozen ice cubes that may block the bail arm from being in the off or upward position. See Automatic Ice Maker-Freezer section in manual.</li> <li>• Periodically move ice cubes around the ice bin so that ice maker will continue to make ice.</li> </ul>

Concern	Potential Cause	Common Solution
<b>Automatic Ice Maker (Cont'd)</b>		
Ice cubes are freezing together.	<ul style="list-style-type: none"> <li>• Ice cubes are not being used frequently enough or interruption of power for prolonged time.</li> <li>• Ice cubes are hollow (shells of ice with water inside). The hollow cubes break open in the bin and leak their water onto existing ice, which causes it to freeze together.</li> </ul>	<ul style="list-style-type: none"> <li>• Remove ice container and discard ice. The ice maker will produce fresh supply. Ice should be used at least twice weekly to keep the cubes separated.</li> <li>• This generally occurs when the ice maker does not get enough water. This is usually the result of a clogged water filter or restricted water supply. Replace the water filter and if the condition still occurs check for a clogged Saddle Valve, water valve not turned on all the way or kinked water supply line.</li> </ul>
<b>Dispenser (Ice &amp; Water)</b>		
Dispenser will not dispense ice.	<ul style="list-style-type: none"> <li>• There is no ice in the bin to be dispensed.</li> <li>• The refrigerator doors are not completely closed.</li> <li>• Dispenser paddle has been pressed too long and the dispenser motor has overheated.</li> </ul>	<ul style="list-style-type: none"> <li>• See the "Ice maker is not making any ice" section above.</li> <li>• Be sure the refrigerator doors are completely closed.</li> <li>• The motor overload protector will reset in about three minutes and then ice can be dispensed.</li> </ul>
Ice dispenser is jammed.	<ul style="list-style-type: none"> <li>• Ice has melted and frozen around auger due to infrequent use, temperature fluctuations, and/or power outages.</li> <li>• Ice cubes are jammed between ice maker and back of ice container.</li> </ul>	<ul style="list-style-type: none"> <li>• Remove ice container, thaw, and empty the contents. Clean container, wipe dry, and replace in proper position. When new ice is made, dispenser should operate.</li> <li>• Remove ice cubes that are jamming the dispenser.</li> </ul>
Dispenser will not dispense water.	<ul style="list-style-type: none"> <li>• Water filter not seated properly.</li> <li>• Water filter is clogged.</li> <li>• Household water line valve is not open.</li> </ul>	<ul style="list-style-type: none"> <li>• Remove and reinstall the water filter. For PurePour, be sure to push the filter in all the way until it clicks into place and is secured inside of the water filter housing.</li> <li>• Replace filter cartridge. Be sure to push filter all the way in until it clicks into place and is secured inside of the water filter housing.</li> <li>• Open household water line valve. See CONCERN column AUTOMATIC ICE MAKER.</li> </ul>

# 46 TROUBLESHOOTING

Concern	Potential Cause	Common Solution
Water not cold enough.	<ul style="list-style-type: none"> <li>The water dispensing system is not designed to chill water.</li> </ul>	<ul style="list-style-type: none"> <li>Add ice to cup or container before dispensing water.</li> </ul>
Water has an odd taste and/or odor.	<ul style="list-style-type: none"> <li>Water has not been dispensed for an extended period of time.</li> <li>Unit not properly connected to cold water line.</li> </ul>	<ul style="list-style-type: none"> <li>Draw and discard 10-12 glasses of water to freshen the supply.</li> <li>Connect unit to cold water line that supplies water to the kitchen faucet.</li> </ul>

Concern	Potential Cause	Common Solution
<b>Opening/Closing Of Doors/Drawers</b>		
Door(s) will not close.	<ul style="list-style-type: none"> <li>Door was closed too hard, causing other door to open slightly.</li> <li>Refrigerator is not level. It rocks on the floor when moved slightly.</li> <li>Refrigerator is touching a wall or cabinet.</li> </ul>	<ul style="list-style-type: none"> <li>Close both doors gently.</li> <li>Ensure floor is level and solid, and can adequately support the refrigerator. Contact a carpenter to correct a sagging or sloping floor.</li> <li>Ensure floor is level and solid, and can adequately support the refrigerator. Contact a carpenter to correct a sagging or sloping floor.</li> </ul>
Drawers are difficult to move.	<ul style="list-style-type: none"> <li>Food is touching shelf on top of drawer.</li> <li>Track that drawers slide on is dirty.</li> </ul>	<ul style="list-style-type: none"> <li>Remove top layer of items in drawer.</li> <li>Ensure drawer is properly installed on track.</li> <li>Clean drawer, rollers, and track. See Care &amp; Cleaning.</li> </ul>

<b>Running of Refrigerator</b>		
Compressor does not run.	<ul style="list-style-type: none"> <li>Freezer control is set to "OF".</li> <li>Refrigerator is in defrost cycle.</li> <li>Plug at electrical outlet is disconnected.</li> <li>House fuse blown or tripped circuit breaker.</li> <li>Power outage.</li> </ul>	<ul style="list-style-type: none"> <li>Set freezer control.</li> <li>This is normal for a fully automatic defrost refrigerator. The defrost cycle occurs periodically, lasting about 30 minutes.</li> <li>Ensure plug is tightly pushed into outlet.</li> <li>Check/replace fuse with a 15 amp time-delay fuse. Reset circuit breaker.</li> <li>Check house lights. Call local electric company.</li> </ul>



Concern	Potential Cause	Common Solution
Refrigerator seems to run too much or too long.	<ul style="list-style-type: none"> <li>Your variable speed compressor is designed to run 100% of the time except during the defrost cycle. At times it will run faster, such as after a defrost cycle.</li> </ul>	<ul style="list-style-type: none"> <li>It is normal for the compressor to run continuously except during defrost mode.</li> </ul>

### Digital Temperature Setting Display

Digital temperature displays an error.	<ul style="list-style-type: none"> <li>Electronic control system has detected a performance problem.</li> </ul>	<ul style="list-style-type: none"> <li>Call your Electrolux service representative, who can interpret any messages or number codes flashing on the digital displays.</li> </ul>
--	---	---

Concern	Potential Cause	Common Solution
---------	-----------------	-----------------

### Water/Moisture/Frost Inside Refrigerator

Moisture collects on inside of refrigerator walls.	<ul style="list-style-type: none"> <li>Weather is hot and humid.</li> <li>Flipper mullion</li> </ul>	<ul style="list-style-type: none"> <li>The rate of frost buildup and internal sweating increases.</li> <li>Adjust flipper mullion. (See “To adjust the flipper mullion” in the Installation section.)</li> </ul>
Water collects on bottom side of drawer cover.	<ul style="list-style-type: none"> <li>Vegetables contain and give off moisture.</li> </ul>	<ul style="list-style-type: none"> <li>It is not unusual to have moisture on the bottom side of the cover. Move humidity control (some models) to lower setting.</li> </ul>
Water collects in bottom of drawer.	<ul style="list-style-type: none"> <li>Washed vegetables and fruit drain while in the drawer.</li> </ul>	<ul style="list-style-type: none"> <li>Water collecting in bottom of drawer is normal. Dry items before putting them in the drawer or store produce in tightly sealed bags to help reduce condensation inside of the drawer.</li> </ul>

### Water/Moisture/Frost Outside Refrigerator

Moisture collects on outside of refrigerator or between doors.	<ul style="list-style-type: none"> <li>Weather is humid.</li> </ul>	<ul style="list-style-type: none"> <li>This is normal in humid weather. When humidity is lower, the moisture should disappear.</li> </ul>
--	---	---

### Food in Fresh Food Compartment

Food is freezing.	<ul style="list-style-type: none"> <li>Temperature setting is too low.</li> <li>Temperature sensor is covered by food (right side of fresh food area).</li> <li>Food is covering the air ports.</li> </ul>	<ul style="list-style-type: none"> <li>Move the setting to a higher degree.</li> <li>Allow space for air flow to the sensor.</li> <li>Allow space between the air ports and the food.</li> </ul>
-------------------	--	--

# 48

## LIMITED WARRANTY

Your appliance is covered by a one year limited warranty. For one year from your original date of purchase, Electrolux will pay all costs for repairing or replacing any parts of this appliance that prove to be defective in materials or workmanship when such appliance is installed, used and maintained in accordance with the provided instructions.

### Exclusions

**This warranty does not cover the following:**

1. Products with original serial numbers that have been removed, altered or cannot be readily determined.
2. Product that has been transferred from its original owner to another party or removed outside the USA or Canada.
3. Rust on the interior or exterior of the unit.
4. Products purchased "as-is" are not covered by this warranty.
5. Food loss due to any refrigerator or freezer failures.
6. Products used in a commercial setting.
7. Service calls which do not involve malfunction or defects in materials or workmanship, or for appliances not in ordinary household use or used other than in accordance with the provided instructions.
8. Service calls to correct the installation of your appliance or to instruct you how to use your appliance.
9. Expenses for making the appliance accessible for servicing, such as removal of trim, cupboards, shelves, etc., which are not a part of the appliance when it is shipped from the factory.
10. Service calls to repair or replace appliance light bulbs, air filters, water filters, other consumables, or knobs, handles, or other cosmetic parts.
11. Surcharges including, but not limited to, any after hour, weekend, or holiday service calls, tolls, ferry trip charges, or mileage expense for service calls to remote areas, including the state of Alaska.
12. Damages to the finish of appliance or home incurred during installation, including but not limited to floors, cabinets, walls, etc.
13. Damages caused by: services performed by unauthorized service companies; use of parts other than genuine Electrolux parts or parts obtained from persons other than authorized service companies; or external causes such as abuse, misuse, inadequate power supply, accidents, fires, or acts of God.

### DISCLAIMER OF IMPLIED WARRANTIES; LIMITATION OF REMEDIES

CUSTOMER'S SOLE AND EXCLUSIVE REMEDY UNDER THIS LIMITED WARRANTY SHALL BE PRODUCT REPAIR OR REPLACEMENT AS PROVIDED HEREIN. CLAIMS BASED ON IMPLIED WARRANTIES, INCLUDING WARRANTIES OF MERCHANTABILITY OR FITNESS FOR A PARTICULAR PURPOSE, ARE LIMITED TO ONE YEAR OR THE SHORTEST PERIOD ALLOWED BY LAW, BUT NOT LESS THAN ONE YEAR. ELECTROLUX SHALL NOT BE LIABLE FOR CONSEQUENTIAL OR INCIDENTAL DAMAGES SUCH AS PROPERTY DAMAGE AND INCIDENTAL EXPENSES RESULTING FROM ANY BREACH OF THIS WRITTEN LIMITED WARRANTY OR ANY IMPLIED WARRANTY. SOME STATES AND PROVINCES DO NOT ALLOW THE EXCLUSION OR LIMITATION OF INCIDENTAL OR CONSEQUENTIAL DAMAGES, OR LIMITATIONS ON THE DURATION OF IMPLIED WARRANTIES, SO THESE LIMITATIONS OR EXCLUSIONS MAY NOT APPLY TO YOU. THIS WRITTEN WARRANTY GIVES YOU SPECIFIC LEGAL RIGHTS. YOU MAY ALSO HAVE OTHER RIGHTS THAT VARY FROM STATE TO STATE.

### If You Need Service

Keep your receipt, delivery slip, or some other appropriate payment record to establish the warranty period should service be required. If service is performed, it is in your best interest to obtain and keep all receipts. Service under this warranty must be obtained by contacting Electrolux at the addresses or phone numbers below.

This warranty only applies in the USA and Canada. In the USA, your appliance is warranted by Electrolux Major Appliances North America, a division of Electrolux Home Products, Inc. In Canada, your appliance is warranted by Electrolux Canada Corp. Electrolux authorizes no person to change or add to any obligations under this warranty. Obligations for service and parts under this warranty must be performed by Electrolux or an authorized service company. Product features or specifications as described or illustrated are subject to change without notice.

#### USA

1.800.374.4432  
Frigidaire  
10200 David Taylor Drive  
Charlotte, NC 28262



**Electrolux**

#### Canada

1.800.265.8352  
Electrolux Canada Corp.  
5855 Terry Fox Way  
Mississauga, Ontario, Canada  
L5V 3E4



# FRIGIDAIRE®

welcome *home*

Our home is your home. Visit us if you need help with any of these things:



owner support



accessories



service



registration

(See your registration card for more information.)

Frigidaire.com  
1-800-374-4432

Frigidaire.ca  
1-800-265-8352



**Use & Care Manual**  
Clothes Dryer

**EN 2**

**Manuel d'utilisation et d'entretien**  
Sécheuse à Chargement Frontal

**FR 48**

**Manual de uso y cuidado**  
Secadora de ropa

**SP 98**



[electroluxappliances.com/register](http://electroluxappliances.com/register)

 **Electrolux**

# 2

## IMPORTANT SAFETY INFORMATION

### Please read and save this manual

Thank you for choosing Electrolux, our premium brand in home appliances. This *Use & Care Manual* is part of our commitment to customer satisfaction and product quality throughout the service life of your new appliance.

We view your purchase as the beginning of a relationship. To ensure our ability to continue serving you, please use this page to record important product information.

### Keep a record for quick reference

Purchase date

Electrolux model number

Electrolux serial number

Electrolux model series\*

\*The series number can be found within the Model number (example ELFE7637AW = 600 series)

### Table of Contents

Important Safety Information.....	2
Features.....	8
Pre-Installation Requirements.....	9
Installation.....	17
Controls and Settings.....	26
Operating Instructions.....	36
Normal Operating Sounds.....	38
Care and Cleaning.....	39
Troubleshooting.....	41
Limited Warranty.....	44

### Questions?

For toll free telephone support or online support in the US and Canada contact:

#### U.S.

1-877-4ELECTROLUX (1-877-435-3287)  
[www.electroluxappliances.com](http://www.electroluxappliances.com)

#### Canada

1-800-265-8352  
[www.electroluxappliances.ca](http://www.electroluxappliances.ca)

#### NOTE

Registering your product with Electrolux enhances our ability to serve you. You can register online at [www.electroluxappliances.com](http://www.electroluxappliances.com), by sending your Product Registration Card in the mail, or PHOTOREGISTER<sup>SM</sup> using a smart phone. See *registration card for details*.

#### NOTE

The instructions appearing in this *Use & Care Manual* are not meant to cover every possible condition and situation that may occur. Common sense and caution must be practiced when installing, operating and maintaining any appliance.

**READ ALL INSTRUCTIONS BEFORE OPERATING THIS DRYER.**

**SAVE THESE INSTRUCTIONS FOR FUTURE REFERENCE.**

---

**Important safety instructions - gas dryer**

---

 **WARNING****FIRE or explosion hazard**

**Failure to follow safety warning exactly could result in serious injury, death, or property damage.**

**DO NOT store or use gasoline or other flammable vapors and liquids in the vicinity of this or any other appliance.**

**WHAT TO DO IF YOU SMELL GAS:**

- **DO NOT try to light any appliance.**
- **DO NOT touch any electrical switch; DO NOT use any phone in your building.**
- **Clear the room, building or area of all occupants.**
- **Immediately call your gas supplier from a neighbor's phone. Follow the gas supplier's instructions.**
- **If you cannot reach your gas supplier, call the fire department.**

**Installation and service must be performed by a qualified installer, service agency or the gas supplier.**

---



## WARNING RISK OF FIRE

- **Ensure the entire dryer exhaust system is clean and free of lint and debris prior to the installation of your new dryer. The entire exhaust system should be inspected and cleaned a minimum of every 18 months with normal usage. Failure to comply with cleaning your exhaust system will increase the RISK of FIRE.**
- DO NOT install a clothes dryer with flexible plastic or flexible foil venting material. Flexible venting materials are known to collapse, be easily crushed and trap lint. These conditions will obstruct clothes dryer airflow and increase the risk of fire.
- DO NOT screen the exhaust ends of the vent system, or use any screws, rivets or other fasteners that extend into the duct to assemble the exhaust system. NO screen or grate of any mesh size is allowed to cover the outdoor exhaust opening.
- Install the clothes dryer according to the manufacturer's instructions and local codes.
- Clothes dryer installation and service must be performed by a qualified installer, service agency or the gas supplier.
- The electrical service to the dryer must conform with local codes and ordinances and the latest edition of the National Electrical Code, ANSI/NFPA 70, or in Canada, the Canadian Electrical Code CSA C22.1 part 1.
- The gas service to the dryer must conform with local codes and ordinances and the latest edition of the National Fuel Gas Code ANSI Z223.1/NFPA 54, or in Canada, the Natural Gas and Propane Installation Code, CSA B149.1. An individual manual shutoff valve must be installed within 6 ft. (1.83 m) of the dryer in accordance with the National Fuel Gas Code, ANSI Z223.1/NFPA 54.
- DO NOT stack a dryer on top of washer already installed on pedestal. DO NOT stack washer on top of dryer. DO NOT stack washer on top of another washer.
- The dryer is designed under ANSI Z21.5.1/CSA 7.1 or UL 2158 - CAN/CSA C22.2 No. 112 (latest editions) for HOME USE only. This dryer is not recommended for commercial applications such as restaurants, beauty salons, etc.
- Destroy the carton and plastic bags after the dryer is unpacked. Children might use them to play. Cartons covered with rugs, bedspreads, or plastic sheets can become airtight chambers causing suffocation. Place all materials in a garbage container or make materials inaccessible to children.
- To reduce the risk of severe injury or death, follow all installation instructions in this manual.

The instructions in this manual and all other literature included with this dryer are not meant to cover every possible condition and situation that may occur. Good safe practice and caution MUST be applied when installing, operating and maintaining any appliance.



### WARNING

For your safety, the information in this manual must be followed to minimize the risk of fire or explosion or to prevent property damage, personal injury or loss of life. DO NOT store or use gasoline or other flammable vapors and liquids in the vicinity of this or any other appliance.



## Definitions

 This is the safety alert symbol. It is used to alert you to potential personal injury hazards. Obey all safety messages that follow this symbol to avoid possible injury or death.



### DANGER

DANGER indicates an imminently hazardous situation which, if not avoided, will result in death or serious injury.



### WARNING

WARNING indicates a potentially hazardous situation which, if not avoided, could result in death or serious injury.



### CAUTION

CAUTION indicates a potentially hazardous situation which, if not avoided, may result in minor or moderate injury.



### IMPORTANT

IMPORTANT indicates installation, operation or maintenance information which is important but not hazard-related.



### WARNING

#### FIRE HAZARD

To reduce the risk of fire, electrical shock, or injury to persons when using this dryer, comply with the basic warnings listed below. Failure to comply with the Important Safety Instruction warnings could result in property damage, serious personal injury, or death.

## Prevent fire

- DO NOT dry items that have been previously cleaned in, soaked in, or spotted with gasoline, cleaning solvents, kerosene, waxes, or other flammable or explosive substances. DO NOT store these items on or near the dryer. These substances give off vapors that could ignite or explode.
- DO NOT place items exposed to cooking oils in your dryer. Items contaminated with cooking oils may contribute to a chemical reaction that could cause a load to catch fire. To reduce the risk of fire due to contaminated loads, the final part of a tumble dryer cycle occurs without heat (cool down period). Avoid stopping a tumble dryer before the end of the drying cycle unless all items are quickly removed and spread out so that the heat is dissipated.
- DO NOT dry articles containing rubber, plastic or similar materials such as bras, galoshes, bath mats, rugs, bibs, baby pants, plastic bags and pillows that may melt or burn. Some rubber materials, when heated, can under certain circumstances produce fire by spontaneous combustion.
- DO NOT operate the dryer if the lint screen is blocked, damaged or missing. Fire hazard, overheating and damage to fabrics can occur.
- DO NOT obstruct the flow of ventilating air. DO NOT stack or place laundry or throw rugs against the front or back of the dryer.



### WARNING

#### FIRE HAZARD

Clean the lint screen before or after each load. **The interior of the dryer, lint screen housing and exhaust duct should be cleaned approximately every 18 months by qualified service professional.** An excessive amount of lint build-up in these areas could result in inefficient drying and possible fire. *See Care and Cleaning.*



### WARNING

#### FIRE HAZARD

A clothes dryer produces combustible lint. The dryer must be connected to an outdoor exhaust. Regularly inspect the outdoor exhaust opening and remove any accumulation of lint around the opening and in the surrounding area.

- DO NOT spray any type of aerosol into, on or near dryer at any time.

# 6

## IMPORTANT SAFETY INFORMATION

---

- DO NOT use fabric softeners or products to eliminate static unless recommended by the manufacturer of the fabric softener or product.



### WARNING

DO NOT continue to use the dryer if you hear squeaking, grinding, rubbing or other unusual noises. This could be a sign of mechanical breakdown and lead to fire or serious injury. **Contact a qualified technician immediately.**

- Failure to comply with these warnings could result in fire, explosion, serious bodily injury and/or damage to the dryer.

### Protect children

- DO NOT allow children to play on or in the dryer. Close supervision of children is necessary when the dryer is used near children. As children grow, teach them the proper, safe use of all appliances.
- Destroy the carton, plastic bag and other packing materials after the dryer is unpacked. Children might use them for play. Cartons covered with rugs, bedspreads or plastic sheets can become airtight chambers.
- Keep laundry products out of children's reach. To prevent personal injury, observe all warnings on product labels.
- Before the dryer is removed from service or discarded, remove the dryer door to prevent accidental entrapment.
- Failure to comply with these warnings could result in serious personal injuries.

### Risk of child entrapment

Child entrapment and suffocation are not problems of the past. Junked or abandoned washers and dryers are still dangerous – even if they will sit for “just a few days”. If you are getting rid of your old washer or dryer, please follow the instructions below to help prevent accidents.

We strongly encourage responsible appliance recycling/disposal methods. Contact your State/Province Energy Office, Local Electric and Water Utilities or Conservation Program Office or visit [www.energystar.gov/recycle](http://www.energystar.gov/recycle) for more information on recycling your old washer or dryer.

### Before you throw away your old washer or dryer:

- Remove doors
- Remove the electric power cord
- Secure all hoses and drain pipes to prevent water from leaking out and creating a slip hazard.

### Prevent injury

- To prevent shock hazard and assure stability during operation, the dryer must be installed and electrically grounded by a qualified service person in accordance with local codes. Installation instructions are included in this manual for reference. Refer to the *installation sections* for detailed grounding procedures. If the dryer is moved to a new location, have it checked and reinstalled by a qualified service professional.
- To prevent personal injury or damage to the dryer, the electrical power cord of a gas dryer must be plugged into a properly grounded and polarized 3-prong outlet. The third grounding prong must never be removed. Never ground the dryer to a gas pipe. DO NOT use an extension cord or an adaptor plug.
- ALWAYS disconnect the dryer from the electrical supply before attempting any service or cleaning. Failure to do so can result in electrical shock or injury.
- DO NOT use any type of spray cleanser when cleaning dryer interior. Hazardous fumes or electrical shock could occur.
- To prevent injury, DO NOT reach into the dryer if the drum is moving. Wait until the dryer has stopped completely before reaching into the drum.

### Prevent injury and damage to the dryer

- All repairs and servicing must be performed by an authorized service provider unless specifically recommended in this *Use & Care Manual*. Use only authorized factory parts.
- DO NOT tamper with controls.
- DO NOT sit on, step on or stand on the dryer. DO NOT rest heavy loads on top. The dryer is not meant to support weight.
- DO NOT install or store the dryer where it will be exposed to water and/or to the weather.

- Thermal limiter switches automatically turn off the motor in the unlikely event of an overheated situation. A service technician must replace the thermal limiter switch(es) after correcting the fault.
- Failure to comply with these warnings could result in serious personal injuries.



## WARNING

### FIRE/ELECTRICAL SHOCK HAZARD

Avoid fire hazard or electrical shock. DO NOT use an adaptor plug or extension cord or remove grounding prong from electrical power cord. Failure to follow this warning can cause serious injury, fire, or death.

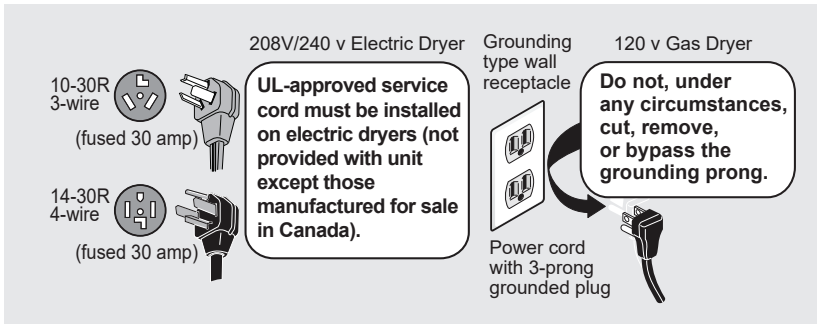





## Installation Checklist

### Exhaust Venting

- Free-flowing, clear of lint buildup
- 4 inch (102 mm) rigid metal or semi-rigid metal transition ducting of minimal length and turns
- NO foil or plastic venting material
- Approved vent hood exhausted to outdoors

### Leveling

- Dryer is level, side-to-side and front-to-back
- Cabinet is sitting solid on all corners

### Gas Supply (Gas Dryer)

- Manual shutoff valve present in supply
- All connections sealed with approved sealer and wrench tight
- Conversion kit for LP GAS system # PCK4200 (not included) and must be purchased separately
- Gas supply turned on
- No leaks present at all connections - check with soapy water, NEVER check with flame

### Water Hookup (Select Models)

- Inspect hoses for proper placement of rubber washers
- Water supply is turned on

- Check for leaks
- Steam model dryers require use of ASSEMBLY HOSE Kit #5304495002 (not included) and must be purchased separately.

### 240v Electric Supply (Electric Dryer)

- Approved NEMA 10-30 or 14-30 service cord with all screws tight on terminal block
- Approved strain relief installed
- Terminal access cover installed before initial operation

### Door Reversal

- Follow detailed instructions in this manual
- Test hinge and latch for function

### Electrical Power

- House power turned on
- Dryer plugged in

### Final Checks

- Installation Instructions and Use & Care Manual read thoroughly
- Door latches and drum tumbles when cycle starts
- Registration card sent in

# 10

## PRE-INSTALLATION REQUIREMENTS

### Tools and materials needed for installation:

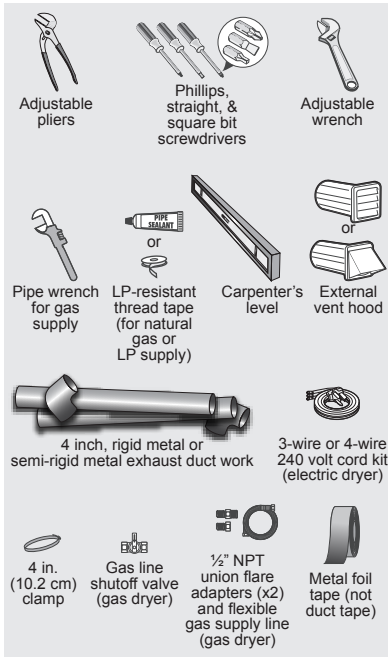

ASSEMBLY HOSE KIT - P/N 5304495002, for steam models only, is not included and must be purchased separately.

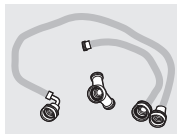

### Electrical system requirements

#### NOTE

Because of potentially inconsistent voltage capabilities, the use of this dryer with power created by gas powered generators, solar powered generators, wind powered generators or any other generator other than the local utility company is not recommended.

#### Electrical requirements for electric dryer:

**CIRCUIT** - Individual 30 amp. branch circuit fused with 30 amp. time delay fuses or circuit breakers. Use separately fused circuits for washer and dryer. **DO NOT** operate washer and dryer on same circuit.

**POWER SUPPLY** - 3-wire or 4-wire, 120/240 volt, single phase, 60 Hz, Alternating Current

#### NOTE

A 120/208 volt, single phase, 60 Hz, Alternating Current supply may be used on dryers marked for use on rating plate.

#### NOTE

The electric dryer has been designed and certified to operate at both 240V and 208V. Drying times on a 208V power supply will, however, be approximately 20% longer than drying times on a 240V power supply. This is normal and expected behavior and applies to all drying cycles.

#### IMPORTANT

Dryer is internally grounded to neutral unless it was manufactured for sale in Canada.

Only a 4-conductor cord shall be used when the appliance is installed in a location where grounding through the neutral conductor is prohibited. Grounding through the neutral link is prohibited for: (1) new branch circuit installations, (2) mobile homes, (3) recreational vehicles, and (4) areas where local codes **DO NOT** permit grounding through the neutral.



#### WARNING

##### FIRE HAZARD

- Failure to follow safety warnings exactly could result in serious injury, death, or property damage.
- **DO NOT** install a booster fan in dryer exhaust duct.
- Install all clothes dryers in accordance with the installation instructions in this manual.

## PRE-INSTALLATION REQUIREMENTS

### 3-wire power supply cord (not supplied)



**3-wire receptacle  
(NEMA type 10-30R)**

The dryer **MUST** employ a 3-conductor power supply cord NEMA 10-30 type SRDT rated at 240 volt AC minimum, 30 amp, with 3 open end spade lug connectors with upturned ends or closed loop connectors and marked for use with clothes dryers. For 3-wire cord connection instructions see "Electrical connection (non-Canada) - 3-wire cord" in Electrical Installation section.

**OUTLET RECEPTACLE** - NEMA 10-30R receptacle to be located so the power supply cord is accessible when the dryer is in the installed position.

**GROUNDING CONNECTION** - See "Grounding requirements" in Electrical Installation section.

### 4-wire power supply cord (not supplied)



**4-wire receptacle  
(NEMA type 14-30R)**

The dryer **MUST** employ a 4-conductor power supply cord NEMA 14-30 type SRDT or DRT (as required) rated at 240 volt AC minimum, 30 amp, with 4 open end spade lug connectors with upturned ends or closed loop connectors and marked for use with clothes dryers. For 4-wire cord connection instructions see "Electrical connection (non-Canada) - 4-wire cord" in Electrical Installation section.



#### NOTE

Dryers manufactured for sale in Canada have factory-installed, 4-wire power supply cord (NEMA 14-30).

**OUTLET RECEPTACLE** - NEMA 14-30R receptacle to be located so the power supply cord is accessible when the dryer is in the installed position.

**GROUNDING CONNECTION** - See "Grounding requirements" in Electrical Installation section.

### Electrical requirements for gas dryer:

**CIRCUIT** - Individual, properly polarized and grounded 15 amp. branch circuit fused with 15 amp. time delay fuse or circuit breaker.

**POWER SUPPLY** - 2-wire, with ground, 120 volt, single phase, 60 Hz, Alternating Current.

**POWER SUPPLY CORD** - Dryer is equipped with 120 volt 3-wire power cord.

**GROUNDING CONNECTION** - See "Grounding requirements" in Electrical Installation section.



#### WARNING

Improper grounding of the dryer may cause serious injury or death. Check with a licensed electrician if you are in doubt as to whether the appliance is properly grounded.

Grounding type wall receptacle



**Do not, under any circumstances, cut, remove, or bypass the grounding prong.**

Power cord with 3-prong grounded plug

### Gas supply requirements



#### WARNING

##### EXPLOSION HAZARD

Uncoated copper tubing will corrode when subjected to natural gas, causing gas leaks. Use **ONLY** black iron, stainless steel, or plastic-coated brass piping for gas supply.

1. The gas service to the dryer must conform with local codes and ordinances and the latest edition of the National Fuel Gas Code ANSI Z223.1/

# 12

## PRE-INSTALLATION REQUIREMENTS

1. NFPA 54, or in Canada, the Natural Gas and Propane Installation Code, CSA B149.1.
2. The gas supply line should be 1/2 inch (1.27 cm) pipe.
3. If codes allow, flexible metal tubing may be used to connect your dryer to the gas supply line. The tubing MUST be constructed of stainless steel or plastic-coated brass.
4. The gas supply line MUST have an individual shutoff valve installed in accordance with the B149.1, Natural Gas and Propane Installation Code.
5. A 1/8 inch (0.32 cm) N.P.T. plugged tapping, accessible for test gauge connection, MUST be installed immediately upstream of the gas supply connection to the dryer.
6. The dryer MUST be disconnected from the gas supply piping system during any pressure testing of the gas supply piping system at test pressures in excess of 1/2 psig (3.45 kPa).
7. The dryer MUST be isolated from the gas supply piping system during any pressure testing of the gas supply piping system at test pressures equal to or less than 1/2 psig (3.45 kPa).
8. Connections for the gas supply must comply with the Standard for Connectors for Gas Appliances, ANSI Z21.24/CSA 6.10.

The following are specific requirements for proper and safe operation of your dryer.



### WARNING

#### FIRE HAZARD

- Failure to follow safety warnings exactly could result in serious injury, death, or property damage.
- **DO NOT** install a booster fan in dryer exhaust duct.
- Install all clothes dryers in accordance with the installation instructions in this manual.

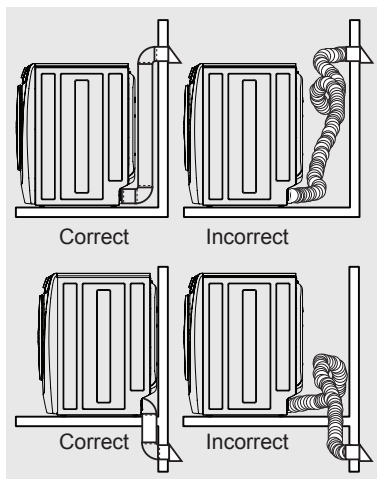

## Exhaust system requirements

Use only 4 inch (102 mm) diameter (minimum) rigid or semi rigid metal duct and approved vent hood which has a swing-out damper or dampers that open when the dryer is in operation. When the dryer stops, the damper or dampers automatically close to prevent drafts and the entrance of insects and rodents. To avoid restricting the outlet, maintain a minimum of 12 inches (30.5 cm) clearance between the vent hood and the ground or any other obstruction.



### WARNING

#### FIRE HAZARD

Failure to follow these instructions can create excessive drying times and fire hazards.





**WARNING**

**FIRE HAZARD**

- A clothes dryer must be exhausted outdoors.
- **DO NOT** exhaust dryer into a chimney, a wall, a ceiling, an attic, a crawl space or any concealed space of a building.
- A clothes dryer produces combustible lint. If the dryer is not exhausted outdoors, some fine lint will be expelled into the laundry area. An accumulation of lint in any area of the home can create a health and fire hazard.
- The dryer must be connected to an exhaust outdoors.
- Regularly inspect the outdoor exhaust opening and remove any accumulation of lint around the outdoor exhaust opening and in the surrounding area.



**WARNING**

**FIRE HAZARD**

- **DO NOT** allow combustible materials (for example: clothing, draperies/curtains, paper) to come in contact with exhaust system. The dryer **MUST NOT** be exhausted into a chimney, a wall, a ceiling, or any concealed space of a building which can accumulate lint, resulting in a fire hazard.
- **DO NOT** screen the exhaust ends of the vent system, or use any screws, rivets or other fasteners that extend into the duct to assemble the exhaust system. **No screen, grate, or guard of any mesh size is allowed to cover the exhaust opening. Lint can become caught in the screen, grate, guard, or on the screws or rivets, clogging the duct work and creating a fire hazard as well as increasing drying times.** Use an approved vent hood to terminate the duct outdoors, and seal all joints with metal foil tape. All male duct pipe fittings **MUST** be installed downstream with the flow of air.



**WARNING**

**FIRE HAZARD**

Never exceed more than 4-90° elbows in the exhaust duct system. Exceeding the length of duct pipe or number of elbows allowed in the "MAXIMUM LENGTH" charts can cause an accumulation of lint in the exhaust system. Plugging the system could create a fire hazard, as well as increase drying times.

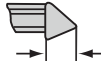
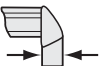
Max. Number of 90° turns	MAXIMUM LENGTH of 4" (102 mm) Rigid Metal Duct	
	VENT HOOD TYPE	
	(Preferred)	
		
	4" (10.2 cm)	louvered 2.5" (6.35 cm)
0	125 ft. (38 m)	110 ft. (33.5 m)
1	115 ft. (35 m)	100 ft. (30.5 m)
2	105 ft. (32 m)	90 ft. (27.5 m)
3	95 ft. (29 m)	80 ft. (24.5 m)
4	85 ft. (26 m)	70 ft. (21.5 m)



**WARNING**

**FIRE HAZARD**

- **DO NOT** install flexible plastic or flexible foil venting material.
- **DO NOT** exceed 8 ft. (2.4 m) duct length if installing semi-rigid venting.
- **DO NOT** use screws, rivets or other fasteners that extend into the duct to assemble the exhaust system.

**Exhaust direction**

Directional exhausting can be accomplished by installing a quick-turn 90° dryer vent elbow directly to exhaust outlet of dryer. Dryer vent elbows are available through your local parts distributor or hardware store.

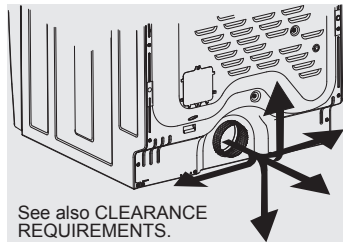

See also CLEARANCE REQUIREMENTS.

**NOTE**

Use of 90° quick-turn elbow required to meet minimum installation depth.

**WARNING****FIRE HAZARD**

**DO NOT** install the dryer where gasoline or other flammables are kept or stored. If the dryer is installed in a garage, it must be a minimum of 18 inches (45.7 cm) above the floor. Failure to do so can result in death, explosion, fire or burns.

In installations where the exhaust system is not described in the charts, the following method must be used to determine if the exhaust system is acceptable:

1. Connect an inclined or digital manometer between the dryer and the point the exhaust connects to the dryer.
2. Set the dryer timer and temperature to **air fluff** (cool down) and start the dryer.
3. Read the measurement on the manometer.
4. The system back pressure **MUST NOT** be higher than 1.0 inch of water column. If the system back pressure is less than 1.0 inch of water column, the system is acceptable. If the manometer reading is higher than 1.0 inch of water column, the system is too restrictive and the installation is unacceptable.

Install male fittings in correct direction:

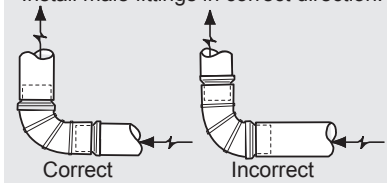

Although vertical orientation of the exhaust system is acceptable, certain extenuating circumstances could affect the performance of the dryer:

- Only the rigid metal duct work should be used.
- Venting vertically through a roof may expose the exhaust system to down drafts causing an increase in vent restriction.

- Running the exhaust system through an uninsulated area may cause condensation and faster accumulation of lint.
- Compression or crimping of the exhaust system will cause an increase in vent restriction.
- **The exhaust system should be inspected and cleaned a minimum of every 18 months with normal usage.** The more the dryer is used, the more often you should check the exhaust system and vent hood for proper operation and that it is free of obstructions.

**Manufactured or mobile home installation**

1. Installation **MUST** conform to current Manufactured Home Construction & Safety Standard, Title 24 CFR, Part 32-80 (formerly the Federal Standard for Mobile Home Construction and Safety for Mobile Homes, Title 24, HUD Part 280) or Standard CAN/CSAZ240 MH.
2. Dryer **MUST** be exhausted outside (outdoors, not beneath the mobile home) using metal ducting that will not support combustion. Metal ducting must be 4 inches (10.16 cm) in diameter with no obstructions. Rigid metal duct is preferred.
3. If dryer is exhausted through the floor and area beneath the mobile home is enclosed, the exhaust system **MUST** terminate outside the enclosure with the termination securely fastened to a non-combustible portion of the mobile home structure.
4. Refer to previous sections in this manual for other important exhaust venting system requirements.
5. When installing a gas dryer into a mobile home, a provision must be made for outside make up air. This provision is to be not less than twice the area of the dryer exhaust outlet.
6. Installer **MUST** anchor this (1) dryer or (2) dryer mounted on pedestal to the floor with approved Mobile Home Installation Kit - P/N 137067200.

Clearance requirements



IMPORTANT

DO NOT INSTALL YOUR DRYER:

1. In an area exposed to dripping water or outside weather conditions.
2. In an area where it will come in contact with curtains, drapes, or anything that will obstruct the flow of combustion and ventilation air.
3. On carpet. Floor MUST be solid with a maximum slope of 1 inch (2.5 cm).

Installation in a recess or closet

1. A dryer installed in a recess or closet, MUST be exhausted outdoors.
2. No other fuel burning appliance shall be installed in the same recess or closet as a gas dryer.
3. Your dryer needs space around it for proper ventilation. See "Clearance Requirements" chart
4. A minimum of 120 square inches of inlet ventilation opening to the recess or closet is required for proper air flow to the dryer.
5. Inlet air ventilation to the recess or closet can be satisfied by adding 120 square inches of opening, equally divided at the top and bottom of the door and located 3 inches from the bottom and top of the door.

or, adding 120 square inches of ventilation openings to the top, sides or rear wall of the closet wall, if the wall is adjacent to an open room, hallway, or exterior.

or, a louvered door with equivalent air openings equaling 120 sq. inches of ventilation for the full length of the door is acceptable.

It is **NOT** approved to derive the 120 sq. inches of ventilation from the space between the door edges and the casing or the floor.

\*\* The presence of forced heating and air-conditioning vent openings in the closet does NOT satisfy the 120 square inch ventilation requirement to the closet.

NOTE

To achieve an installation with 0" (0 cm) clearance for the back of the dryer (for other than straight back venting), a quick-turn 90° dryer vent elbow must be installed as described previously in this manual.

For other than straight back venting, a quick-turn 90° dryer vent elbow must be installed to achieve 0" (0 cm) installation.

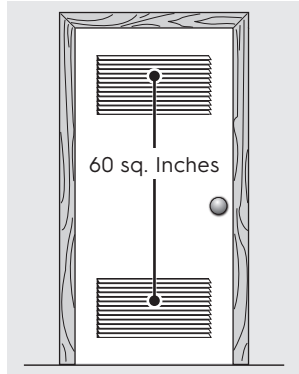

120 sq. Inches Equally Divided Split Vent Door

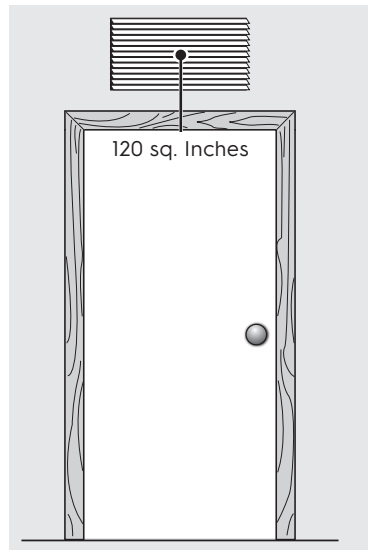

Solid Door with Wall Ventilation

# 16

## PRE-INSTALLATION REQUIREMENTS

120 sq. Inches min.  
Louvered Opening

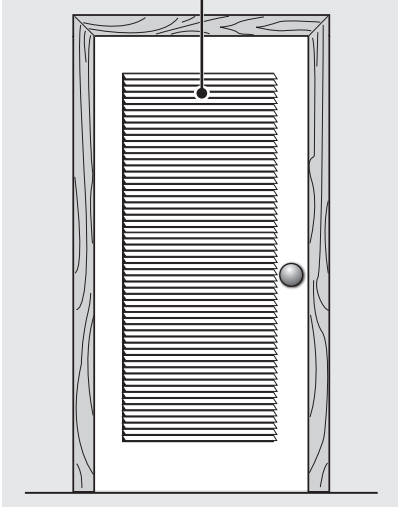

Louvered Door

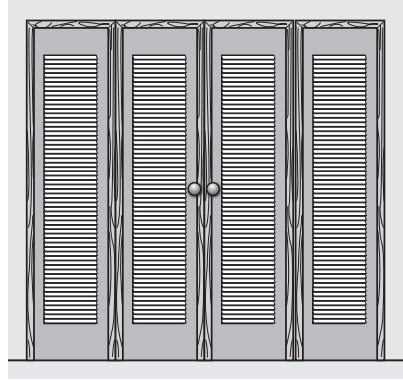

Bi-Fold louvered doors with  
120 sq. in of ventilation

120 sq. Inches of  
wall venting

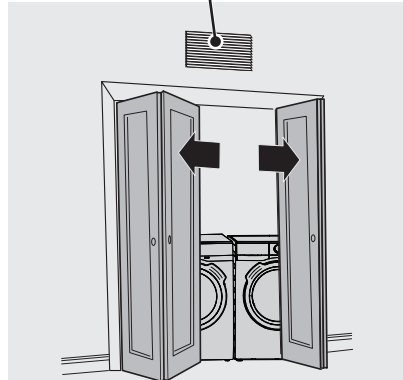

Solid Bi-Fold doors with no  
ventilation

### MIN INSTALLATION CLEARANCES - Inches (cm)

	Sides	Rear	Top	Front
Alcove/ recess	0" (0 cm)	0" (0 cm)	0" (0 cm)	Open
Closet with door vent	0" (0 cm)	0" (0 cm)	0" (0 cm)	1" (2.5 cm)
Closet with wall vent	1" (2.5 cm)	1" (2.5 cm)	1" (2.5 cm)	1" (2.5 cm)

## Dryer dimensions

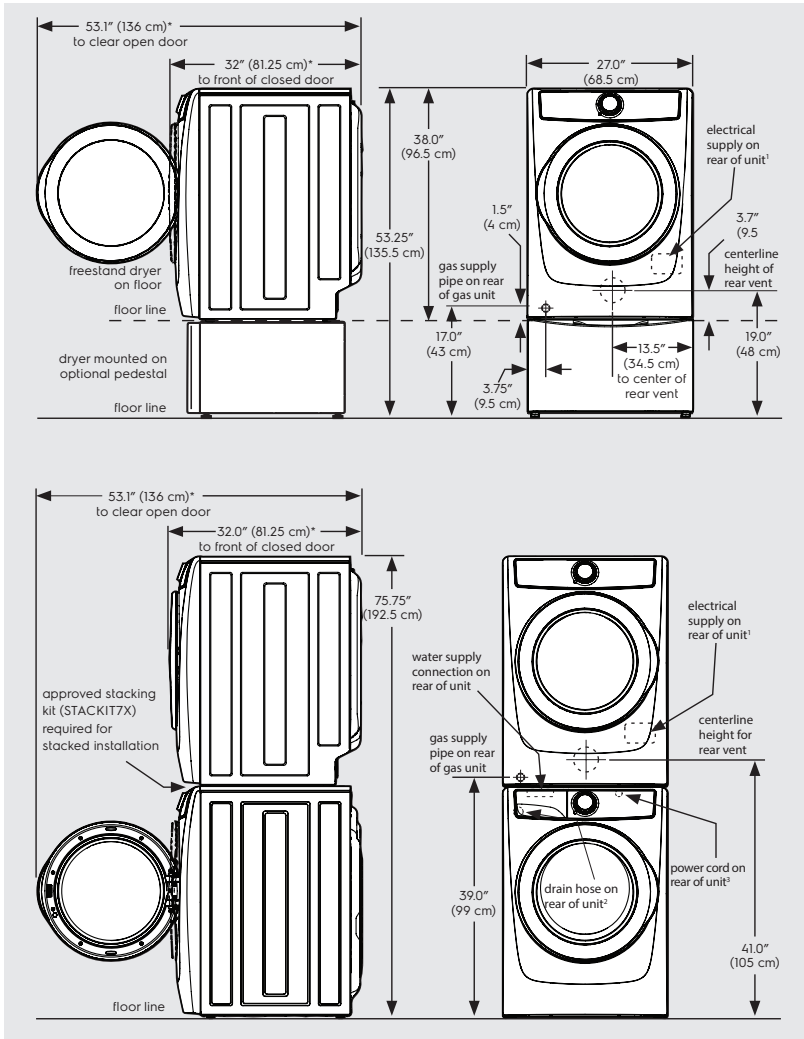

\* Connection of water inlet hose on steam dryer adds 3/4 in. (2 cm) to installation depth.

<sup>1</sup> Power supply cord length on gas dryer or electric Canadian dryer approximately 60 inches (152.5 cm).

<sup>2</sup> Drain hose length on washer approximately 59 inches (150 cm).

<sup>3</sup> Power supply cord length on washer approximately 60 inches (152.5 cm).

# 18

## INSTALLATION

### Connecting the electrical system

The following are specific requirements for proper and safe electrical installation of your dryer. Failure to follow these instructions can create electrical shock and/or a fire hazard.



#### WARNING

##### ELECTRICAL SHOCK HAZARD

- This appliance **MUST** be properly grounded. Electrical shock can result if the dryer is not properly grounded. Follow the instructions in this manual for proper grounding.
- **DO NOT** use an extension cord with this dryer. Some extension cords are not designed to withstand the amounts of electrical current this dryer utilizes and can melt, creating electrical shock and/or fire hazard. Locate the dryer within reach of the receptacle for the length power cord to be purchased, allowing some slack in the cord. Refer to the *Pre-Installation Requirements* section of this manual for the proper power cord to be purchased.



#### WARNING

##### ELECTRICAL SHOCK HAZARD

- A U.L.-approved strain relief must be installed onto power cord. If the strain relief is not attached, the cord can be pulled out of the dryer and can be cut by any movement of the cord, resulting in electrical shock.
- **DO NOT** use an aluminum wired receptacle with a copper wired power cord and plug (or vice versa). A chemical reaction occurs between copper and aluminum and can cause electrical shorts. The proper wiring and receptacle is a copper wired power cord with a copper wired receptacle.



#### NOTE

Dryers operating on 208 volt power supply will have longer drying times than dryers operating on 240 volt power supply.

The dryer, when installed, must be electrically grounded in accordance with local codes and the National Electrical code ANSI/NFPA 70 or the Canadian Electrical Code, Part 1, CSA C22.1.

### Grounding requirements - electric dryer (USA)



#### WARNING

Improper grounding of the dryer may cause serious injury or death. Check with a licensed electrician if you are in doubt as to whether the appliance is properly grounded.

### For a grounded, cord-connected dryer:

1. The dryer **MUST** be grounded. In the event of a malfunction or breakdown, grounding will reduce the risk of electrical shock by providing a path of least resistance for electrical current.
2. After you purchase and install a 3-wire or 4-wire power supply cord having an equipment-grounding conductor and a grounding plug that matches your wiring system, the plug **MUST** be plugged into an appropriate, copper wired receptacle that is properly installed and grounded in accordance with all local codes and ordinances. If in doubt, call a licensed electrician.
3. **DO NOT** modify the plug you've installed on this appliance. If it will not fit the outlet, have a proper outlet installed by a qualified electrician.

### For a permanently connected dryer:

The dryer **MUST** be connected to a grounded metal, permanent wiring system; or an equipment grounding conductor must be run with the circuit conductors and connected to the equipment-grounding terminal or lead on the appliance.

## Grounding requirements - electric dryer (Canada)



### WARNING

Improper grounding of the dryer may cause serious injury or death. Check with a licensed electrician if you are in doubt as to whether the appliance is properly grounded.

### For a grounded, cord-connected dryer:

1. The dryer **MUST** be grounded. In the event of a malfunction or breakdown, grounding will reduce the risk of electrical shock by providing a path of least resistance for electrical current.
2. Since your dryer is equipped with a power supply cord having an equipment-grounding conductor and a grounding plug, the plug must be plugged into an appropriate outlet that is properly installed and grounded in accordance with all local codes and ordinances. If in doubt, call a licensed electrician.
- 3 **DO NOT** modify the plug provided with this appliance. If it will not fit the outlet, have a proper outlet installed by a qualified electrician.

## Grounding requirements - gas dryer

1. The dryer is equipped with a three-prong (grounding) plug for your protection against shock hazard and should be plugged directly into a properly grounded three-prong receptacle.
2. The plug must be plugged into an appropriate outlet that is properly installed and grounded in accordance with all local codes and ordinances. If in doubt, call a licensed electrician.
- 3 **DO NOT** modify the plug provided with this appliance. If it will not fit the outlet, have a proper outlet installed by a qualified electrician.



### WARNING

Improper grounding of the dryer may cause serious injury or death. Check with a licensed electrician if you are in doubt as to whether the appliance is properly grounded.

Grounding type wall receptacle



**Do not, under any circumstances, cut, remove, or bypass the grounding prong.**

Power cord with  
3-prong grounded plug



# 20 INSTALLATION

## Electrical connection (non-Canada) - 3 wire cord



3-wire receptacle  
(NEMA type 10-30R)



### WARNING

#### ELECTRICAL SHOCK HAZARD

Failure to disconnect power source before servicing could result in personal injury or even death.



### WARNING

#### ELECTRICAL HAZARD

Label all wires prior to disconnection when servicing controls. Wiring errors can cause improper and dangerous operation. Verify proper operation after servicing.

1. Turn off power supply to outlet
2. Remove the screw securing the terminal block access cover in the lower corner on the back of the dryer.
3. Install a UL-approved strain relief according to the power cord/strain relief manufacturer's instructions in the power cord entry hole below the access panel. At this time, the strain relief should be loosely in place.
4. Thread an UNPLUGGED, UL-approved, 30 amp. power cord, NEMA 10-30 type SRDT, through the strain relief.
5. Attach the power cord neutral (center wire) conductor to the SILVER colored center terminal on the terminal block. Tighten the screw securely.
6. Attach the remaining two power cord outer conductors to the outer, BRASS colored terminals on the terminal block. Tighten both screws securely.



### WARNING

#### ELECTRICAL SHOCK HAZARD

**DO NOT** make a sharp bend or crimp wiring/conductor at connections.

7. Follow manufacturer's guidelines for firmly securing the strain relief and power cord.
8. Reinstall the terminal block cover.



### IMPORTANT

If moving dryer from a 4-wire system and installing it in a 3-wire system, move the internal ground from the center terminal back to the GREEN screw next to the terminal block.

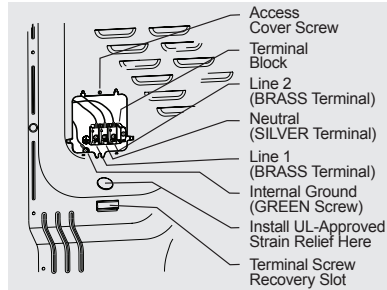
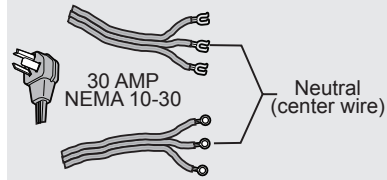

### NOTE

If a terminal screw falls during cord installation, it can be retrieved in the terminal screw recovery slot below the access panel.

**DO NOT** remove internal ground in a 3-wire system!!

Neutral terminal

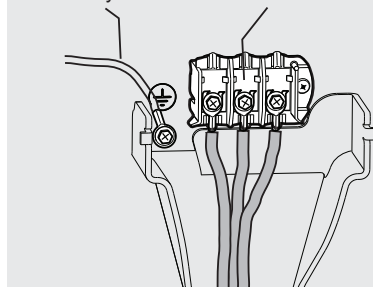



**Electrical connection  
(non-Canada) - 4 wire cord**

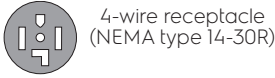

**WARNING**

**ELECTRICAL SHOCK HAZARD**

Failure to disconnect power source before servicing could result in personal injury or even death.

**WARNING**

**ELECTRICAL HAZARD**

Label all wires prior to disconnection when servicing controls. Wiring errors can cause improper and dangerous operation. Verify proper operation after servicing.

1. Turn off power supply to outlet.
2. Remove the screw securing the terminal block access cover in the lower corner on the back of the dryer.
3. Install a UL-approved strain relief according to the power cord/strain relief manufacturer's instructions in the power cord entry hole below the access panel. At this time, the strain relief should be loosely in place.
4. Thread an UNPLUGGED, UL-approved, 30 amp. power cord, NEMA 14-30 type DRT or SRDT, through the strain relief.
5. Disconnect the internal (WHITE) dryer harness ground wire from the (GREEN) ground screw next to terminal block.
6. Attach the ground (GREEN) power cord wire to the cabinet with the ground (GREEN) screw. Tighten the screw securely.
7. Move the internal dryer harness ground (WHITE) wire to the terminal block and attach it along with the neutral (WHITE) power cord wire conductor to center, SILVER colored terminal on the terminal block. Tighten the screw securely.
8. Attach the RED and BLACK power cord conductors to the outer, BRASS colored terminals on the terminal block. Tighten both screws securely.

**WARNING**

**ELECTRICAL SHOCK HAZARD**

**DO NOT** make a sharp bend or crimp wiring/conductor at connections.

9. Follow manufacturer's guidelines for firmly securing the strain relief and power cord.
10. Reinstall the terminal block cover.

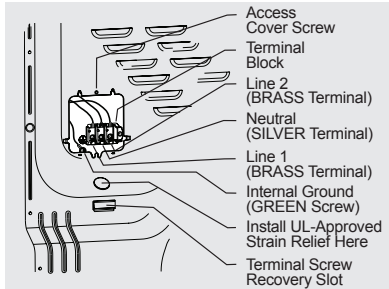
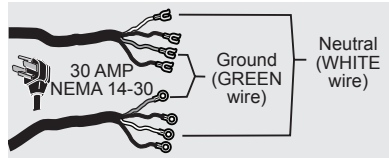

**NOTE**

If a terminal screw falls during cord installation, it can be retrieved in the terminal screw recovery slot below the access panel.

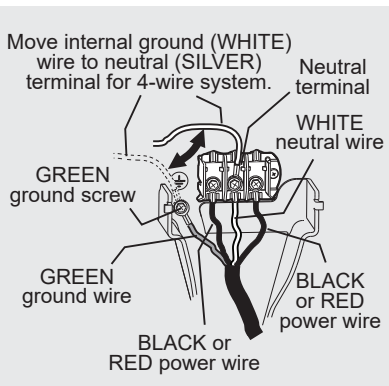

# 22 INSTALLATION

## Connecting the gas

1. Remove the shipping cap from gas pipe at the rear of the dryer.



### WARNING

**DO NOT** connect the dryer to L.P. gas service without converting the gas valve. An L.P. conversion kit PN# PCK4200 (not included) **must be installed by a qualified gas technician.**

2. Connect a 1/2 inch (1.27 cm) I.D. semi-rigid or approved pipe from gas supply line to the 3/8 inch (0.96 cm) pipe located on the back of the dryer. Use a 1/2 inch to 3/8 inch (1.27 cm to 0.96 cm) reducer for the connection. Apply an approved thread sealer that is resistant to the corrosive action of liquefied gases on all pipe connections.

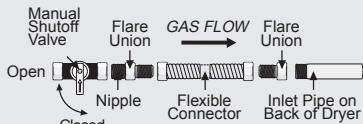

3. Open the shutoff valve in the gas supply line to allow gas to flow through the pipe. Wait a few minutes for gas to move through the gas line.



### IMPORTANT

The supply line must be equipped with an approved manual shutoff valve. This valve should be located in the same room as the dryer and should be in a location that allows ease of opening and closing. **DO NOT** block access to the gas shutoff valve.

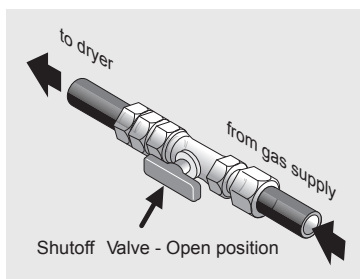

4. Check for gas system leaks with a manometer. If a manometer is not available, test all connections by brushing on a soapy water solution.



### WARNING

#### EXPLOSION HAZARD

NEVER test for gas leaks with an open flame.



### IMPORTANT

Installation to the gas service must follow local codes and ordinances and the latest edition of the National Fuel Gas Code ANSI Z223.1/NFPA 54 or in Canada, CSA B149.1.

## Connecting the water (steam models only)



### WARNING

Periodically inspect all water inlet hoses for water leaks, wear, cuts, corrosion and bulges. Replace all hoses, if any sign of the above is visible. All hoses should be replaced every 5 years to reduce the risk of hose failures.

## Water supply requirements

Cold water faucet **MUST** be installed within 42 inches (107 cm) of your dryer's water inlet. The faucet **MUST** be 3/4 inch (1.9 cm) with threading for laundry hose connection. Water pressure **MUST** be between 20 and 120 psi. Your water department can advise you of your water pressure.

1. Turn off COLD water supply to washer.

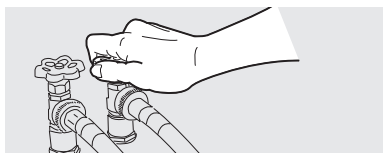

2. Remove COLD inlet hose from COLD water supply and inspect for rubber washer. Replace washer if it is torn or worn out.

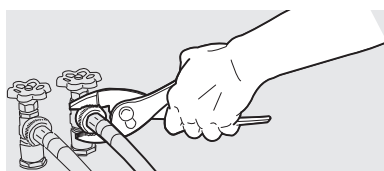

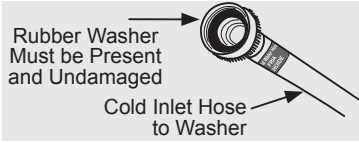

- Turn on COLD supply and run water to clear any contaminants in the line.



- Inspect hose couplings for proper placement of rubber washers. Use hoses from ASSEMBLY HOSE KIT# 5304495002 (not included).

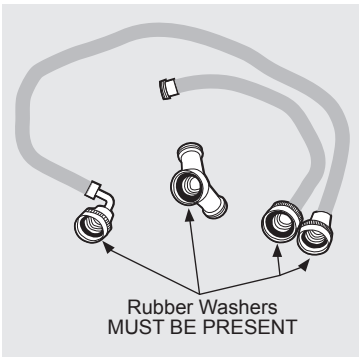

- If your installation has room for the COLD water supply to accept the "Y" connector directly, thread the "Y" connector to the COLD water supply and snug it by hand; then tighten it another 2/3 turn with pliers.

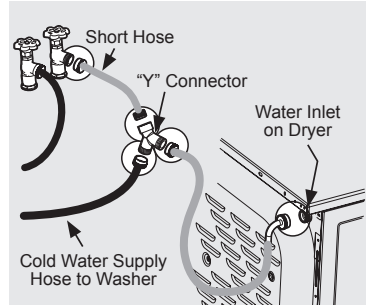

- If there is not room to install the "Y" connector directly, thread the short extension hose on to the COLD water supply and snug it by hand; then tighten it another 2/3 turn with pliers.

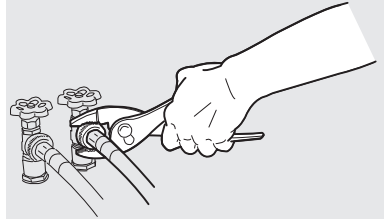

- Thread the "Y" connector to the short extension hose and snug it by hand; then tighten it another 2/3 turn with pliers.
- Connect the COLD inlet hose for the washer to the "Y" connector and snug it by hand; then tighten it another 2/3 turn with pliers.
- Connect the straight end of the long hose from the kit to the other outlet on the "Y" connector and snug it by hand. Connect the hose's 90° coupling to the brass water inlet on the back of the dryer and snug it by hand. Tighten each connection of the dryer inlet hose another 2/3 turn with pliers.
- Turn on the water and check for leaks at all connections.

## NOTE

If you were able to install the "Y" connector directly to the COLD water supply, please skip to step 8.

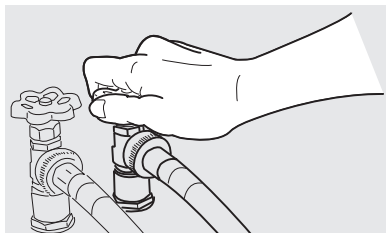

# 24 INSTALLATION

## Completing the installation

1. Connect the exhaust duct to the outside exhaust system. Use of a 4" (102 mm) clamp (item A) is recommended to connect the dryer to the exhaust vent system. Use metal foil tape to seal all other joints.

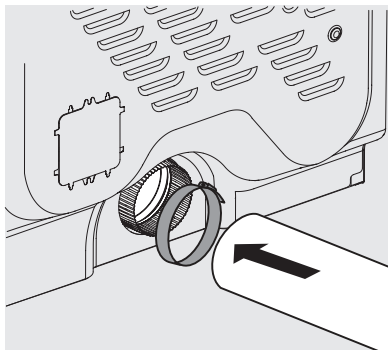

2. Use a carpenter's level to level your dryer front-to-back and side-to-side.
3. Use adjustable pliers to adjust the leveling legs so the dryer is level front-to-rear and side-to-side, and stable corner-to-corner.

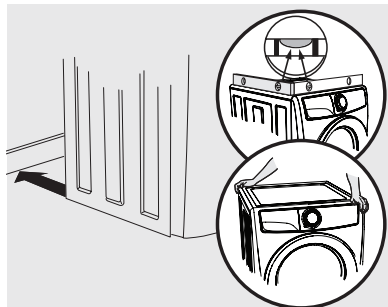

4. Press down on alternate corners and sides and feel for the slightest movement. Adjust the appropriate leg(s) so the dryer sits solidly on the floor on ALL four legs. Keep the leveling leg extension at a minimum for best performance of the dryer.

5. Plug the power cord into a grounded outlet.



### WARNING

Improper grounding of the dryer may cause serious injury or death. Check with a licensed electrician if you are in doubt as to whether the appliance is properly grounded.

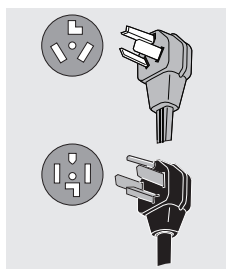

### WARNING

Do not store combustible materials, gasoline, and other flammable vapors and liquids near this dryer.

6. Turn on the power at the circuit breaker/fuse box.
7. Read the Use & Care Manual provided with the dryer. It contains valuable and helpful information that will save you time and money.
8. If you have any questions during initial operation, please review the "Avoid Service Checklist" in your Use & Care Manual before calling for service.
9. Place these instructions in a location near the dryer for future reference.



### NOTE

A wiring diagram and technical data sheet are located under the dryer top panel.



### IMPORTANT

Be sure the power is off at a circuit breaker/fuse box before plugging the power cord into an outlet.



### CAUTION

When discarding or storing your old dryer, remove the door.

## Reversing the door

### NOTE

Door reversibility is available on all dryer models.

### IMPORTANT

#### BEFORE YOU REVERSE YOUR DRYER DOOR:

1. Be sure you have adequate swing area before reversing door.
2. Gather your tools - including a screw driver with a #2 square bit and plastic knife (or small, flat prying tool that won't damage paint).
3. Be sure dryer is unplugged from power source!

Tools needed for reversal:

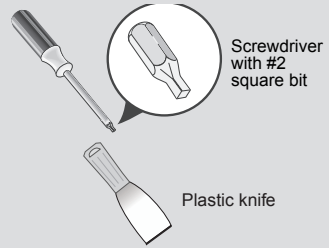

### WARNING

#### ELECTRICAL SHOCK HAZARD

Failure to disconnect power source before servicing could result in personal injury or even death.

## Removing latch and hole plugs

1. Open the door.
2. Remove plastic hole plugs and save to reinstall later. You may have to use a non-scratching plastic knife if you are unable to dislodge the plugs manually.

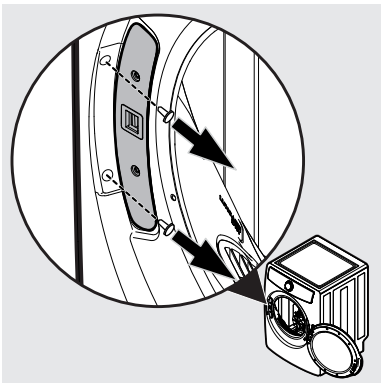

3. Remove both screws from door latch. Save latch and screws for reinstallation later.

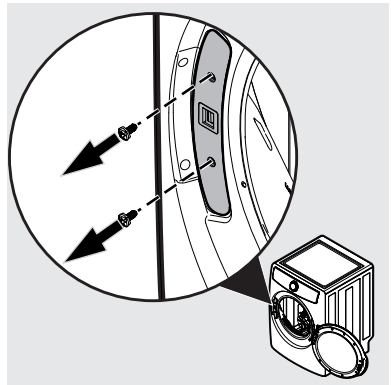

# 26 INSTALLATION

## Removing door assembly

1. Completely open the door to expose all four hinge screws.
2. Remove all four hinge screws with #2 square bit driver. Save for reinstalling later.

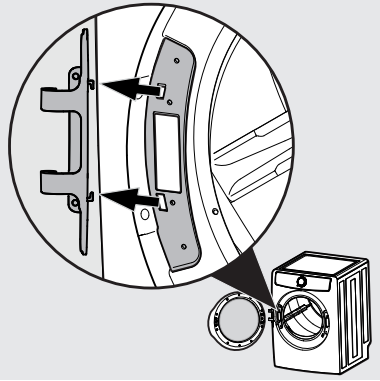

3. Grasp the door with both hands and lift slightly as you pull door and hinge away from the front panel.

## Reinstalling door assembly

1. Rotate the door and hang the upper hook on the back of the hinge in the upper hole of the front panel.

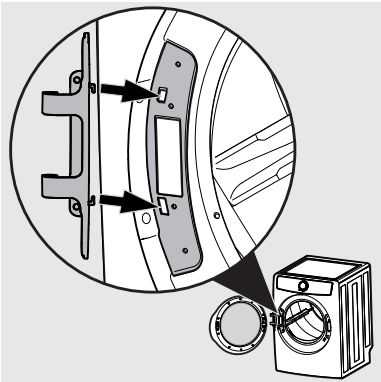

2. Reinstall and tighten all four screws removed earlier - two front screws first, then two side screws.

## Reinstalling latch and hole plugs

1. Install door latch with screws removed earlier.

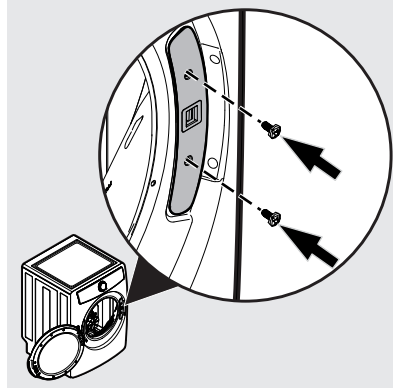

2. Insert plastic hole plugs removed earlier.

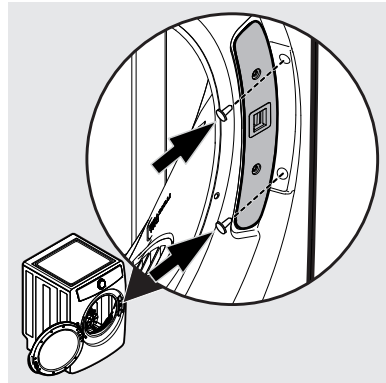

## Verify reversed door operation

1. Test door for free, smooth swinging operation and secure latching when closed.
2. Plug in dryer and close the door. Start a test cycle: drum should tumble until door is pulled open or cycle is paused or canceled.

## Accessories

### MATCHING STORAGE PEDESTAL\*

White Pedestal - P/N EPWD257UIW

Titanium Pedestal - P/N EPWD257UTT

A storage pedestal accessory, specifically designed for this dryer may be used to elevate the dryer for ease of use. This pedestal will add about 15" (38 cm) to the height of your unit.

\*Other colors may be available. Contact the source where you purchased your dryer.

### DRYER STACKING KIT

P/N STACKIT7X

Depending on the model you purchased, a kit for stacking a matching dryer on top of this washer may have been included in the initial purchase of your dryer. If your model did not include a stacking kit or you desire another stacking kit, you may order one.

### LP CONVERSION KIT

P/N PCK4200

Gas dryers intended for use in a location supplied with LP must use a conversion kit prior to installation.

### MOBILE HOME INSTALLATION KIT

P/N 137067200

Installations in mobile homes require use of MOBILE HOME INSTALLATION KIT.

### UNIVERSAL APPLIANCE WRENCH

P/N 137019200

A UNIVERSAL APPLIANCE WRENCH is available to aid in dryer/washer/pedestal feet adjustment.

### TOUCH UP PAINT PENS

White - P/N 5304468812

Titanium - P/N 5304475700

\*Other colors may be available. Contact the source where you purchased your dryer.

### ASSEMBLY HOSE KIT

P/N 5304495002

For use in dryer models that include a steam feature.



## WARNING

Failure to use accessories manufactured by (or approved by) the manufacturer could result in personal injury, property damage or damage to the dryer.

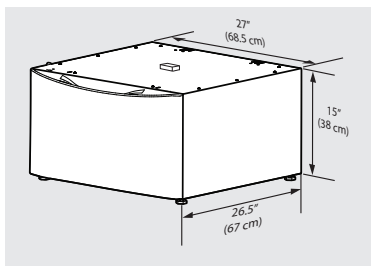

Storage Pedestal

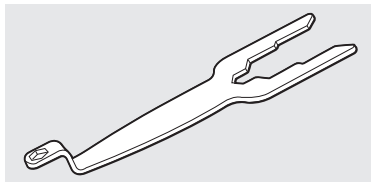

Universal Appliance Wrench

## Replacement parts in U.S. and Canada

If replacements parts are needed for your dryer, you can contact the source where you purchased your dryer, call 1-877-4ELECTROLUX (1-877-435-3287) in the U.S. or 1-800-265-8352 in Canada, or visit our website, [www.electroluxappliances.com](http://www.electroluxappliances.com) in the U.S. or [www.electroluxappliances.ca](http://www.electroluxappliances.ca) in Canada for the Electrolux Authorized Parts Distributor nearest you.

# 28 CONTROLS AND SETTINGS

## Model series

### 300 SERIES

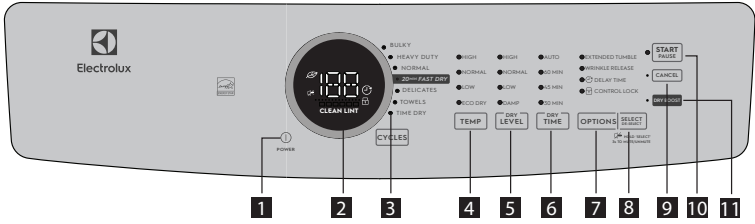

### 400 SERIES

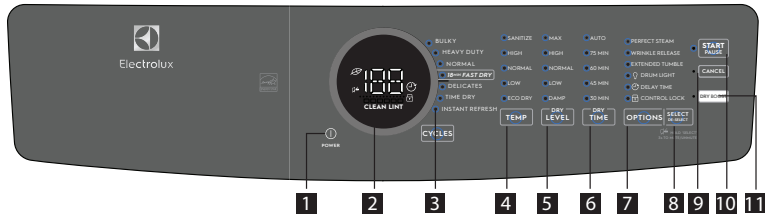

### 500 SERIES

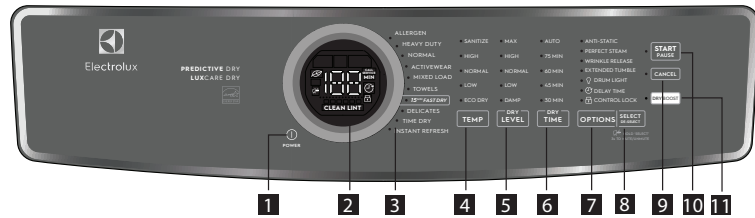

### 600 SERIES GAS/ELECTRIC

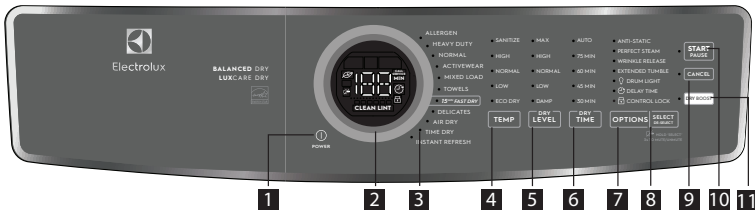

- |                        |                           |                            |
|------------------------|---------------------------|----------------------------|
| <b>1</b> POWER         | <b>2</b> Cycle Selector   | <b>3</b> Cycle LED Display |
| <b>4</b> Temp Selector | <b>5</b> DRY LEVEL        | <b>6</b> DRY TIME          |
| <b>7</b> Options       | <b>8</b> SELECT/DE-SELECT | <b>9</b> CANCEL            |
| <b>10</b> START/PAUSE  | <b>11</b> DRY BOOST       |                            |

This manual covers many models and not all cycles, options, or features listed are available on every model. Consoles shown above for reference only. Your model may differ.



## Setting chart - 300 series dryer

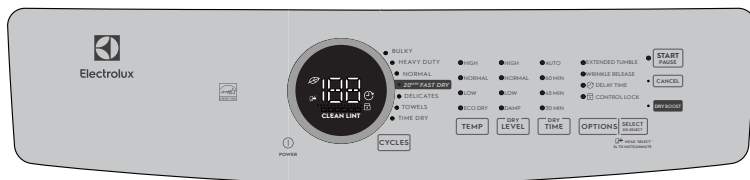

These temperature, dryness levels and options are available with the following cycles:

		CYCLE SELECTIONS							
		BULKY	HEAVY DUTY	NORMAL	20 MIN FAST DRY	DELICATES	TOWELS	TIME DRY	
CYCLE SETTINGS	<b>TEMPERATURE (temp)</b>		✓	✓		✓		✓	✓
		High	✓	✓		✓		✓	✓
		Normal		✓	✓			✓	✓
		Low			✓		✓	✓	✓
		Eco Dry							✓
		<b>DRYNESS</b>		✓	✓	✓			✓
		High	✓	✓	✓			✓	
		Normal		✓	✓		✓	✓	
		Low			✓		✓		
		Damp			✓		✓		
	<b>Dry Time</b>		✓	✓	✓		✓	✓	
	Auto Dry	✓	✓	✓		✓	✓		
	60 Min							✓	
	45 Min							✓	
	30 Min							✓	
CYCLE OPTIONS	<b>OPTIONS</b>		✓	✓	✓		✓	✓	✓
		Extended Tumble	✓	✓	✓		✓	✓	✓
		Wrinkle Release	✓	✓	✓		✓	✓	✓
		Delay Time	✓	✓	✓	✓	✓	✓	✓
		Control Lock	✓	✓	✓	✓	✓	✓	✓
		Dry Boost	✓	✓	✓	✓	✓	✓	✓

✓ = Available selections. □ = Factory presets. ■ = Non-modifiable presets.

# 30 CONTROLS AND SETTINGS

## Setting chart - 400 series dryer



These temperature, dryness levels and options are available with the following cycles:

### CYCLE SELECTIONS

	BULKY	HEAVY DUTY	NORMAL	18 MIN FAST DRY	DELICATES	TIME DRY	INSTANT REFRESH
--	-------	------------	--------	-----------------	-----------	----------	-----------------

### TEMPERATURE (temp)

Sanitize	✓	✓				✓	
High	✓	✓		✓		✓	✓
Normal		✓	✓			✓	
Low			✓		✓	✓	
Eco Dry						✓	

### DRYNESS

Max	✓	✓	✓				
High		✓	✓				
Normal		✓	✓		✓		
Low			✓		✓		
Damp			✓		✓		

### DRY TIME

Auto Dry	✓	✓	✓		✓		
75 Min						✓	
60 Min						✓	
45 Min						✓	
30 Min						✓	

### OPTIONS

Perfect Steam			✓		✓		✓
Wrinkle Release	✓	✓	✓		✓	✓	
Extended Tumble	✓	✓	✓		✓	✓	
Drum Light	✓	✓	✓	✓	✓	✓	✓
Delay Time	✓	✓	✓	✓	✓	✓	✓
Control Lock	✓	✓	✓	✓	✓	✓	✓
Dry Boost	✓	✓	✓	✓	✓	✓	

✓ = Available selections. ◻ = Factory presets. ◼ = Non-modifiable presets.

## Setting chart - 500 series dryer



These temperature, dryness levels and options are available with the following cycles:

### CYCLE SELECTIONS

ALLERGEN	HEAVY DUTY	NORMAL	ACTIVE WEAR	MIXED LOADS (COLORS)	TOWELS	15 MIN FAST DRY	DELICATES	TIME DRY	INSTANT REFRESH
----------	------------	--------	-------------	----------------------	--------	-----------------	-----------	----------	-----------------

### TEMPERATURE (temp)

Sanitize	✓	✓				✓			✓
High	✓	✓		✓	✓	■		✓	■
Normal		✓	✓	✓	✓	✓		✓	
Low			✓	✓	✓	✓	✓	✓	
Eco Dry (No Heat/Air)								✓	

### DRYNESS

Max	■	✓	✓			✓			
High		✓	✓	✓	✓	✓			
Normal		✓	✓	✓	✓	✓	✓		
Low			✓	✓	✓			✓	
Damp			✓		✓			✓	

### DRY TIME

Auto Dry	■	✓	✓	✓	✓	■		✓	
75 Min									✓
60 Min									✓
45 Min									✓
30 Min									✓

### OPTIONS

Anti-Static		✓	✓	✓	✓	✓		✓	
Perfect Steam			✓	✓	✓	✓		✓	■
Wrinkle Release	✓	✓	✓	✓	✓	✓		✓	✓
Extended Tumble	✓	✓	✓	✓	✓	✓		✓	✓
Drum Light	✓	✓	✓	✓	✓	✓	✓	✓	✓
Delay Time	✓	✓	✓	✓	✓	✓	✓	✓	✓
Control Lock	✓	✓	✓	✓	✓	✓	✓	✓	✓
Dry Boost	■	✓	✓	✓	✓	✓	✓	✓	

✓ = Available selections. □ = Factory presets. ■ = Non-modifiable presets.

CYCLE SETTINGS

CYCLE OPTIONS

# 32 CONTROLS AND SETTINGS

## Setting chart - 600 series dryer



These temperature, dryness levels and options are available with the following cycles:

### CYCLE SELECTIONS

	ALLERGEN	HEAVY DUTY	NORMAL	ACTIVE WEAR	MIXED LOADS (COLORS)	TOWELS	15 MIN FAST DRY	DELICATES	AIR DRY	TIME DRY	INSTANT REFRESH
--	----------	------------	--------	-------------	----------------------	--------	-----------------	-----------	---------	----------	-----------------

### TEMPERATURE (temp)

Sanitize	✓	✓				✓					✓
High	✓	✓			✓	✓	■			✓	■
Normal		✓	✓		✓	✓				✓	
Low			✓	✓	✓	✓		✓		✓	
Eco Dry (No Heat/Air)									✓	✓	

### DRYNESS

Max	■	✓	✓			✓					
High		✓	✓	✓	✓	✓					
Normal		✓	✓	✓	✓	✓		✓			
Low			✓	✓	✓			✓			
Damp			✓		✓			✓	✓		

### Dry Time

Auto Dry	■	✓	✓	✓	✓	✓		✓	✓		
75 Min											✓
60 Min											✓
45 Min											✓
30 Min											✓

### OPTIONS

Anti-Static		✓	✓	✓	✓	✓		✓			
Perfect Steam			✓	✓	✓	✓		✓			✓
Wrinkle Release	✓	✓	✓	✓	✓	✓		✓	✓	✓	
Extended Tumble	✓	✓	✓	✓	✓	✓		✓	✓	✓	
Drum Light	✓	✓	✓	✓	✓	✓		✓	✓	✓	✓
Delay Time	✓	✓	✓	✓	✓	✓	✓	✓	✓	✓	✓
Control Lock	✓	✓	✓	✓	✓	✓	✓	✓	✓	✓	✓
Dry Boost	■	✓	✓	✓	✓	✓	✓	✓		✓	

✓ = Available selections. ◻ = Factory presets. ■ = Non-modifiable presets.

CYCLE SETTINGS

CYCLE OPTIONS

## Cycle selection



### Selecting the right cycle to save energy

This dryer has been specifically designed with options to help you save energy and at the same time utilize the optimal drying setting for your clothing.

**The normal cycle was used to rate the dryer for energy efficiency. The normal cycle resets to normal temperature setting, normal dryness level.**

Some cycles save more energy than others. Cycles that use the least amount of heat save the most energy and display the leaf icon  on the console. Use the lowest heat setting (auto and timed dry cycles) and less dry setting (auto dry cycles) to save on energy and prevent over drying your clothing.

Press the **power** button to turn on the unit. Turn the cycle selector in either direction or repeatedly press the cycles button (depending on your model) to scroll to the desired cycle. The indicator light for the cycle selected will be illuminated and the estimated drying time for Auto Dry cycles or the actual drying time for Time Dry cycles will be displayed on the LED display screen.

Default settings and options will automatically be indicated for the cycle selected. In most cases cycle settings and options can be changed. See *Cycle Settings*, *Cycle Options*, and *Setting Charts* for more details.

To change the cycle once it has begun, press the **cancel** button before selecting a new cycle. **Turning the cycle selector ring or pressing the cycles button WILL NOT change the cycle.**

### Auto dry cycles

Auto dry cycles take the guesswork out of selecting the correct drying time for each load. Moisture sensors sense the moisture level of the load as it tumbles through the heated air. With auto dry cycles, the load will automatically be dried at the selected temperature to the desired dryness level.

Auto dry cycles save time and energy and protect fabrics. When the load has reached the selected dryness level, it will continue to tumble, unheated, during a cool down period. This helps reduce wrinkling and makes items easier to handle during unloading.



### NOTE

Initial cycle times for auto dry cycles are only estimates, the actual drying time may differ slightly from the time displayed.

Drying times vary depending on size and dampness of the load and fabric type. If the load is too small or almost dry, the moisture

sensors may not detect enough moisture to continue the cycle and the cycle may end after a few minutes. If this occurs, then select the **time dry** cycle to dry such loads.

Room temperature and humidity, type of installation and electrical voltage or gas pressure can also affect drying time.



### NOTE

Models equipped with the **Predictive Dry** feature use the first 90 seconds of Auto Dry cycles to sense the load in the dryer. **During this 90 second period the LED display will show 2 circling lines.** When the sensing is complete, the LED display will show the remaining cycle time in minutes and accurately count down to the end of the cycle.

### Timed dry cycles

The timed drying cycles allow the selection of exact drying times. The **time dry** cycle allows the option to select drying time settings ranging from **30** to **75** minutes (depending on the model). Various drying times and temperature settings can be selected when using this cycle.

The **fast dry** cycles (on select models) have preset times of **15**, **18** or **20** minutes (dependent on model) with a preset temperature of **high** only.

Dryness levels will not be an available option when using either of the timed drying cycles.



### WARNING

#### FIRE HAZARD

To avoid fire hazard, DO NOT use heat to dry items containing feathers or down, foam rubber, plastics similarly textured, rubber-like materials. Use the **time dry** cycle and the **eco dry** (no heat) setting.

# 34 CONTROLS AND SETTINGS

## Cycles

LOAD	LOAD TYPE	CYCLE PRESET
<b>ALLERGEN</b> (select models)	Allergen removal (not for items prone to heat damage)	<ul style="list-style-type: none"> <li>high temperature*</li> <li>maximum dryness*</li> <li>auto dry*</li> </ul>
<b>BULKY</b> (select models)	Large loads and durable fabrics (such as towels, jeans and overalls)	<ul style="list-style-type: none"> <li>high temperature</li> <li>maximum dryness</li> <li>auto dry*</li> </ul>
<b>HEAVY DUTY</b> (select models)	Large loads and durable fabrics (such as jeans and overalls)	
<b>NORMAL</b>	Everyday loads (cottons, linens and sheets)	<ul style="list-style-type: none"> <li>normal temperature</li> <li>normal dryness</li> <li>auto dry*</li> </ul>
<b>ACTIVEWEAR</b> (select models)	Lightweight synthetic athletic apparel (synthetic athletic fabrics and stretch fabrics)	<ul style="list-style-type: none"> <li>low temperature</li> <li>normal dryness</li> <li>auto dry*</li> </ul>
<b>MIXED LOAD</b> (select models)	Mixed load of fabrics	<ul style="list-style-type: none"> <li>normal temperature</li> <li>normal dryness</li> <li>auto dry*</li> </ul>
<b>TOWELS</b> (select models)	Large loads and durable fabrics (such as towels, jeans and overalls)	<ul style="list-style-type: none"> <li>high temperature*</li> <li>maximum dryness*</li> <li>auto dry*</li> </ul>
<b>FAST DRY</b> (varies by model) <b>15/18/20 min.</b>	Small loads of 3 to 5 garments	<ul style="list-style-type: none"> <li>high temperature*</li> <li>preset time* (15,18 or 20 minutes)</li> </ul>
<b>DELICATES</b>	Knit fabrics and delicates	<ul style="list-style-type: none"> <li>low temperature*</li> <li>normal dryness</li> <li>auto dry*</li> </ul>
<b>TIME DRY</b>	Manually set drying time, heat and dry level for any type of load	<ul style="list-style-type: none"> <li>normal temperature</li> <li>30-75 minutes time</li> </ul>
<b>AIR DRY</b>	Small loads of 3 to 5 garments	<ul style="list-style-type: none"> <li>no heat</li> </ul>
<b>INSTANT REFRESH</b> (select models)	Refresh fabrics, remove odors and reduce static by injecting steam into clothing.	<ul style="list-style-type: none"> <li>high temperature*</li> <li>perfect steam™*</li> </ul>

\* setting can not be changed from preset

### NOTE

It is not recommended to use fabric softener sheets with steam cycles or steam options as it may cause staining on clothes.

### NOTE

To change a cycle setting once the cycle has begun, press the **start/pause** button, make the new selection and press **start/pause** again.

## Cycle settings

To set or change the drying temperature, dryness level, or drying time press the **temp**, **dryness** or **time dry** buttons to scroll to the desired settings. The indicator light for each setting will be illuminated when selected.

To protect your fabrics, not all temperatures or dryness levels are available with every cycle. If a temperature or dryness level is not appropriate for the cycle, it cannot be selected and will not be lit when scrolling through the settings.

With exception of the **sanitize** and **perfect steam™**, adjustments made to cycle settings and options will be remembered and recalled each time that cycle is selected in the future.

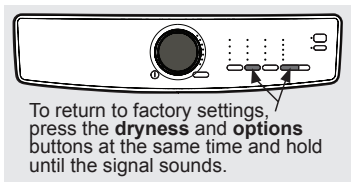

### Drying temperature (temp)

To change the temperature, press the **temp** button to scroll to the desired setting.



#### For best results

Follow the fabric care label instructions on items to be dried.

#### sanitize (on select models)

Recommended for durable fabrics and towels. Use this selection to remove harmful bacteria from your clothing or other items where sanitization is desired. This option will kill 99.9% of bacteria using a higher temperature required to kill bacteria. Please check fabric care labels to prevent damage.

#### high

Recommended for most cotton fabrics.

#### normal

Recommended for wrinkle free, easy care, lightweight fabrics and bulky loads.

#### low (on select models)

Recommended for delicate fabrics.

#### eco dry (no heat)

This setting should only be used with a time dry cycle to dry items containing feathers, down, foam rubber, plastics or rubber-like materials; to refresh clothing, stuffed animal, pillows or blankets; and to dust draperies.

### Dryness level (dryness)

To set or change the dryness level, press the **dryness** button to scroll to the desired setting.

The dryness levels include **max** (on select models), **high**, **normal**, **low** (on select models), and **damp**. Most Auto Dry cycles default to the **normal** dryness level.

Occasionally a load may seem too damp or over-dried at the end of the cycle. To increase drying time for similar loads in

the future, select **high** or **max** (on select models). To decrease drying time for similar loads, select **less** (on select models).

Select **damp** for items you wish to partially dry before hanging or ironing.

### Drying time (time dry)

Manually select or change the drying time for a **time dry** cycle (on select models) by pressing the **time dry** button to scroll through the available options. Time dry options include **30, 45, 60 and 75** minutes (dependent on model).

The **auto** selection is a default for all **auto dry** cycles and **fast dry** cycles and cannot be selected or changed. All actual or predicted dry times will count down on the LED display.

### Cycle options

To select an option, press **options** and scroll through the options until the indicator light for the desired option flashes, then press **select (set)**. The indicator will illuminate when the option has been selected. Follow the same steps to deselect an option. The indicator light will turn off when the option is deselected.



#### NOTE

To change a cycle option once the cycle has begun, press the **start/pause** button, make the new selection and press **start/pause** again.

To protect your fabrics, not all options are available with every cycle. If an option is not available for a cycle, the indicator will not light.

Occasionally, two options or settings in the same cycle will conflict with each other, like the **perfect steam** option and **sanitize** temperature (on select models). When this happens, the option selected first will cause the conflicting option to not be selectable.



**perfect steam™ (on select models)** The **perfect steam™** option injects steam into the clothing prior to cool down to reduce wrinkling, ironing and static cling.

# 36 CONTROLS AND SETTINGS

## NOTE

It is not recommended to use fabric softener sheets with steam cycles or steam options as it may cause staining on clothes.

### anti-static (on select models)

The **anti-static** option injects steam into the clothing just before cycle completion to reduce static.

### dry boost

This option increases the drying effectiveness for difficult loads. In conjunction with Automatic moisture sensors and the dry boost option may slightly decrease cycle times.

### leaf icon

This icon will appear on the console when the dryer is using energy efficient settings. These settings use less heat and longer cycle times to dry. The dryer will always default to the energy efficient Normal cycle with the leaf icon displayed.

### wrinkle release

The **wrinkle release** option helps prevent wrinkles and tangling by tumbling the dry load without heat for 5 minutes out of every 10 minutes. The 5 minutes on and 5 minutes off is repeated for a total 45 minutes. A chime will sound after each tumble as a reminder to remove the dried load.

## NOTE

When **extended tumble** and **wrinkle release options are both selected** the amount of time the load will tumble without heat will increase to a period of up to 75 minutes.

### extended tumble (on select models)

Select the **extended tumble** option if the dried load might not be removed promptly at the end of the cycle. The dried load will tumble continuously without heat for 30 minutes. A chime will sound periodically to remind you to remove the dried load.

### delay time (on select models)

Use **delay time** to delay the start of the drying cycle to a time convenient to your schedule or during off-peak energy hours. The start of any cycle can be delayed for 30 minutes to 12 hours. After selecting the delay time option, use the cycle button

(models 300/400) or the cycle selector (models 500/600) to scroll to the desired delay time and press **start**. The **delay time** icon will illuminate on the LED display to indicate the **delay time** option is activated. The delay time will begin counting down on the LED display once activated.

## NOTE

While counting down during **delay time**, you will notice your dryer periodically tumbling for a few minutes without heat to redistribute the load, maximizing load freshness.

### control lock

To lock the controls between cycles, scroll to the control lock option and press **select**. The control lock icon will show on the LED display. To unlock the controls scroll to the control lock option again and press **select**. Use this feature to reduce the likelihood of accidental operation by children. **Dryer cycles will not run when Control Lock is activated.**

### chime

A signal will sound at the end of the cycle (and periodically during **extended tumble** or **wrinkle release**). To mute or unmute the chime, press and hold the **select** button for 3 seconds.



 hold 'select' 3 s to mute/unmute

## Other features

### LED display



*Icons may vary according to model.*



The estimated cycle time for **auto dry**, the actual time for **time dry**, or the **delay time countdown** will be displayed when the cycle is selected. Once the cycle has started, the estimated remaining time will be displayed for the remainder of the cycle.

As the dryer progresses through the cycle phases, the row of cycle phase indicators lights up under the cycle time.

**Delay time, leaf, control lock, mute** icons (select models) and **CLEAN LINT** will also appear on this LED display when activated.

#### Drum light (on select models)

The drum light will come on whenever the door is opened to illuminate the drum during loading and unloading. Closing the door turns off the light. The drum light will automatically turn off if the door is left open more than 3 minutes. Select the **drum light** option to enable or disable the drum light.

#### Reversible door

The dryer is equipped with a reversible door. The door can be hinged on the right or left side.



#### NOTE

For step-by-step instructions on door reversal, refer to the *installation* sections of this manual.

#### LuxCare™ Lint Shield filter

The dryer is equipped with a clamshell style LuxCare™ Lint Shield filter.

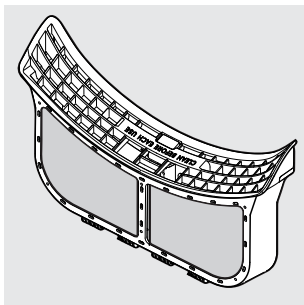

#### WARNING

Clean the filter after every load. A **CLEAN LINT message** will appear on the LED display at the end of the cycle to remind you to remove the lint from the filter.



#### NOTE

For step-by-step instructions cleaning the lint filter, refer to *Cleaning the Filter* in the Care and Cleaning section of this Use & Care Manual.

# 38 OPERATING INSTRUCTIONS

## Operating the dryer



### WARNING

To reduce the risk of fire, electric shock or injury to persons, read the Important Safety Information in this *Use & Care Manual* before operating your dryer.



### WARNING

DO NOT operate dryer without lint filter in place.



### WARNING

Clean the lint filter after every load.

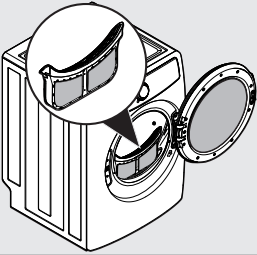
STEPS	TIPS	IMPORTANT
1. Prepare load for drying.	<ul style="list-style-type: none"> <li>• Dry items of similar fabric, weight and construction in the same load.</li> <li>• Separate dark items from light-colored items. Separate items that shed lint from those that attract lint.</li> <li>• Check for stains which may not have been removed in washing. Repeat stain removal process and wash again before drying. Dryer heat may permanently set some stains.</li> <li>• Place delicate, rubber coated, or small items in a mesh bag (not included).</li> <li>• Be sure buckles, buttons and trim are heatproof and won't damage the drum finish. Close zippers; fasten hooks and loop fasteners. Tie strings and sashes to prevent snagging and tangling.</li> </ul>	<p><b>DO NOT</b> machine wash items containing fiberglass. Small particles of fiberglass left in drum may transfer to fabrics in other loads and cause skin irritation and/or damage to fabrics.</p> <p><b>DO NOT</b> wash water resistant and water repellent type clothing or other materials.</p>
2. Check that the lint filter is clean and in place.		<p><b>DO NOT</b> operate dryer without lint filter in place.</p>
3. Load the dryer and close the door.	<ul style="list-style-type: none"> <li>• Load items loosely. The average wet load will fill the drum 1/3 to 1/2 full. Items need room to tumble freely for even drying and less wrinkling.</li> <li>• If desired, place a dryer fabric softener sheet on top of the load at the beginning of the cycle.</li> <li>• When drying large items, dry only two or three items at a time. Fill out the load with smaller items.</li> <li>• For delicate or very small loads, add two or three similar items to improve tumbling action.</li> </ul>	<p>DO NOT overload the dryer. To save energy, time and avoid uneven drying and wrinkling avoid overloading the dryer.</p> <p>DO NOT over-dry. Over-drying can cause wrinkles, shrinkage, lint, and a build up of static electricity.</p>

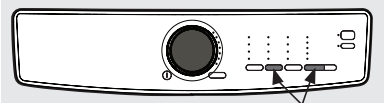
STEPS	TIPS	IMPORTANT
<p>1. Select the appropriate cycle and settings for each load.</p>	<ul style="list-style-type: none"> <li>• See <i>Cycle Selection</i> and <i>Cycle Settings</i> for detailed descriptions of cycle controls.</li> <li>• See <i>Cycle Setting Charts</i> to determine which settings are available for each cycle.</li> <li>• To provide the best care, not every setting or option is available with every cycle. If a setting or option is not available for the cycle selected, the indicator will not light. See <i>Setting Chart</i> for information of available options for each cycle by model.</li> <li>• Adjustments made to most cycle settings will be remembered each time the cycle is selected in the future. When the dryer is powered on, the default cycle will be the normal cycle. Select your desired cycle and previous settings will remain. To return to factory settings, press the dryness button and the options button at the same time and hold until the signal sounds.</li> </ul> 	<p>Over-drying can cause wrinkles, shrinkage, lint, harshness, and a build up of static electricity.</p> <p>To prevent unintentional and accidental exposure of delicate material to excess heat or unexpected steam, the <b>sanitize</b> temperature setting and the <b>perfect steam™</b> option will not be remembered and must be reselected each time.</p>
<p>2. Close the dryer door and start the drying cycle.</p>	<ul style="list-style-type: none"> <li>• To start the drying cycle, close the door and press the <b>start/pause</b> button.</li> <li>• To add an item to the dryer drum, press <b>start/pause</b>. Add the item, close the door and press <b>start/pause</b> to resume the cycle.</li> <li>• To change settings or options after the cycle has begun, press <b>start/pause</b>, change the settings, and then press <b>start/pause</b>. If the cycle is not paused first, the unit will emit several beeps when the buttons are pressed but no changes to the cycle will be applied.</li> <li>• To change the cycle once the cycle has begun, press <b>cancel</b> to cancel the cycle, select the new cycle, and press <b>start/pause</b> to begin the new cycle. Changing a cycle selection without cancelling the current <b>WILL NOT</b> change the cycle.</li> <li>• To cancel a cycle, press <b>cancel</b>.</li> </ul>	<p>The dryer <b>will not</b> operate with the door open.</p> <p>When drying a single large or bulky item, such as a comforter, pause the cycle part way through to turn the item “inside out” and maximize drying effectiveness.</p>
<p>3. Remove items when done.</p>	<ul style="list-style-type: none"> <li>• A signal will sound at the end of the cycle if the chime option is not set to mute.</li> <li>• Immediately remove items when the cycle is completed and hang or fold.</li> </ul>	<p>See product manufacturer’s instructions.</p>
<p>4. Clean the lint filter.</p>	<ul style="list-style-type: none"> <li>• See Care and Cleaning section of this instruction.</li> <li>• <b>CLEAN LINT</b> will be displayed at the end of the cycle as a reminder to remove lint from filter.</li> </ul>	<p><b>ALWAYS REMOVE LINT at the end of the cycle (see warning on previous page).</b></p>

## Normal operating sounds

You may or may not hear the following sounds from your new dryer:

- 1. WATER VALVE** (Steam models only)  
The flow of water is controlled by electric solenoids. During operation there may be a clicking sound as the valve opens and closes to control the water flow.
- 2. SUSPENSION ROLLERS** The dryer drum is supported by a set of suspension rollers. At times there may be a thumping or rolling sound when the dryer starts. This may happen if the dryer has not been in use for a period of time, or after a heavy load has remained in the dryer drum for an extended period, creating a temporary flat spot on the edge of the roller. The noise should dissipate as the dryer operates and the flat spots smooth out.
- 3. AIR FLOW SYSTEM** Your dryer is equipped with a high volume air handling system. In some installations there may be some sounds associated with air movement throughout the dryer, including the air duct, blower, and exhaust system. This is normal and can vary with load size and type.
- 4. GAS VALVE** (Gas models only.) The flow of gas is controlled by electric solenoids. During operation there may be a clicking sound as the valve opens and closes to control the gas flow.
- 5. GAS BURNER** (Gas models only.) When the burner is operating, there may be sounds generated as the air flow mixes with the gas flame. This noise is normal and will only occur when the gas is ignited in the combustion tube.

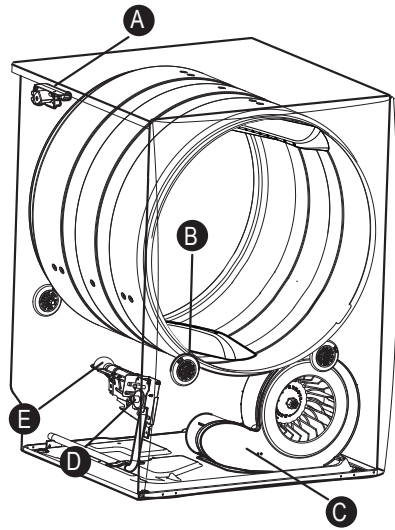

## Before operating your dryer

Read the important instructions in this section of the *Use & Care Manual* before operating your dryer.



### WARNING

To reduce the risk of fire, electric shock or injury to persons, read the Important Safety Information in this *Use & Care Manual* before operating your dryer.

**WARNING**

To reduce risk of fire or serious injury to persons or property, comply with the basic warnings listed in the Important Safety Information and those listed below.

**Cleaning the filter****WARNING**

Clean the lint filter after every load. **CLEAN LINT** will be displayed at the end of the cycle to remind you to remove lint from the filter.

Clean the lint filter after every load. Lint build-up on the filter restricts air flow, which causes longer drying times. The filter is located at the bottom of the door opening.

**Cleaning the LuxCare™ Lint Shield filter**

1. Remove the filter by pulling it straight up from the dryer.

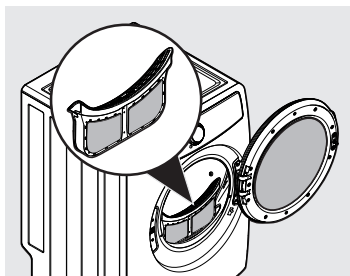

2. Press down the button on the top of the filter to open the clamshell.

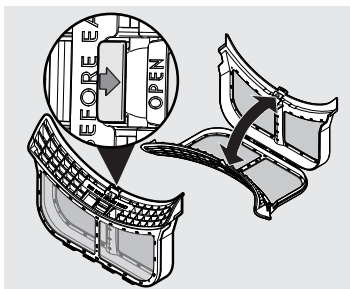

3. Gently clean the lint from the filter.

4. Snap the filter closed and place back into the dryer.

**IMPORTANT**

- DO NOT open the clamshell filter beyond the hinge limit.
- ALWAYS handle the clamshell filter by the frame, not by the mesh material.

**Inside**

- Occasionally a waxy build-up may form on the lint filter and/or moisture sensing bars from using dryer-added fabric softener sheets. To remove this build-up, wash them with warm, soapy water. Dry the filter thoroughly and replace. DO NOT operate the dryer without the lint filter in place.
- If the dryer drum becomes stained from non colorfast fabrics, clean the drum with a damp cloth and a mild liquid household cleanser. Remove cleanser residue before drying the next load.
- Before cleaning the dryer drum interior, unplug the electrical power cord to avoid electrical shock hazards.
- DO NOT use any type spray cleanser when cleaning the dryer interior. Hazardous fumes or electrical shock could occur.
- **Every 18 months a qualified service professional should clean the dryer cabinet interior, lint screen housing and exhaust duct. These areas can collect lint and dust over time. An excessive amount of lint build-up could result in inefficient drying and possible fire hazard.**

**Outside**

- Clean the dryer cabinet with mild soap and water. Never use harsh, gritty or abrasive cleansers.
- If the cabinet becomes stained, clean with diluted chlorine bleach (1 part bleach to 8 parts water). Rinse several times with clear water.
- Remove glue residue from tape or labels with a mixture of warm water and mild detergent. Or, touch residue with the sticky side of the tape or label.

# 42 CARE AND CLEANING

- When cleaning chrome parts, it is best to use only a damp cloth.
- Before moving the dryer, place a strip of cardboard or thin fiberboard under the front leveling legs to prevent damage to the floor.



## WARNING

### FIRE HAZARD

A clothes dryer produces combustible lint. The dryer must be connected to an outdoor exhaust. Regularly inspect the outdoor exhaust opening and remove any accumulation of lint around the opening and in the surrounding area.



## IMPORTANT

DO NOT store or place laundry products on top of dryer at any time. They can damage the finish or controls. It is recommended to keep laundry products in the storage drawer between cycles if installed on a pedestal.



## Water inlet hose inspection (steam models only)

Periodically inspect all water inlet hoses for water leaks, wear, cuts, corrosion and bulges. Replace all hoses, if any sign of the above is visible. All hoses should be replaced every 5 years to reduce the risk of hose failures. When replacing hoses, refer to the *installation instructions* for proper installation. DO NOT overtighten or cross

thread the fittings. DO NOT allow the hose to rub against sharp objects. Always ensure the hose fitting rubber gasket is installed and free from water leaks when water pressure is applied.

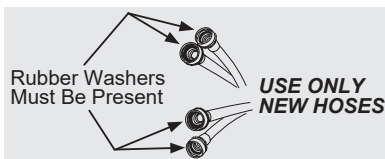

## Limited use, vacation, and away from home



## CAUTION

Your dryer should be operated ONLY when you are home. If you are away from home or not using your dryer for extended periods of time, follow these steps:

1. Turn off the water supply to dryer (steam models only) to avoid water leaks due to water pressure surges and unforeseen occurrences in the water supply.
2. Disconnect or unplug the electrical power to the dryer.

## Reconnecting water supply and electrical



## IMPORTANT

When reinstalling the dryer after disconnecting the water supply lines (steam models only) and electrical power, please follow the steps below:

1. Review the *installation instructions* provided with the dryer to ensure the appliance is level and the water and electrical power supply is properly connected.
2. Ensure the water lines are flushed of debris, prior to connecting the water lines to the dryer inlet.
3. Check for water leaks and replace supply hoses if needed.

## Common drying inquiries

Many drying problems involve poor cleaning results, poor soil and stain removal, residues of lint and scum, and fabric damage. For satisfactory drying results, follow these suggestions provided by The Soap and Detergent Association.

PROBLEM	POSSIBLE CAUSES	SOLUTIONS	PREVENTIVE MEASURES
Greasy, oily stains	<ul style="list-style-type: none"> <li>• Fabric softener sheet</li> </ul>	<ul style="list-style-type: none"> <li>• Rub fabric softener stains with bar soap. Rinse and rewash.</li> </ul>	<ul style="list-style-type: none"> <li>• Add a few bath towels to small loads for proper tumbling.</li> <li>• Some “silk-like” fabrics should be air dried.</li> <li>• Use proper drying temperature.</li> <li>• Place fabric softener sheet on top of load before starting the dryer.</li> </ul>
Lint	<ul style="list-style-type: none"> <li>• Overloading</li> <li>• Overdrying causes static electricity</li> <li>• Lint screen not clean when cycle began</li> <li>• Lint is attached to “pills”</li> </ul>	<ul style="list-style-type: none"> <li>• Reduce load size and rewash using liquid fabric softener in the final rinse.</li> <li>• Or, add a fabric softener sheet and tumble without heat.</li> <li>• Use lint brush or roller to remove lint.</li> </ul>	<ul style="list-style-type: none"> <li>• DO NOT overload dryer.</li> <li>• Use fabric softener in washer or dryer to reduce static electricity.</li> <li>• Remove items when they are slightly damp to avoid overdrying.</li> <li>• Check that lint filter is clean and in place.</li> </ul>
Pilling (fibers break off, ball up and cling to fabric)	<ul style="list-style-type: none"> <li>• Overdrying</li> </ul>	<ul style="list-style-type: none"> <li>• Use a lint brush or shaver to remove pills.</li> </ul>	<ul style="list-style-type: none"> <li>• Use fabric softener to lubricate fibers.</li> <li>• When ironing, use spray starch or fabric finish on collars and cuffs.</li> <li>• Turn items inside out to reduce abrasion.</li> </ul>
Shrinking	<ul style="list-style-type: none"> <li>• Temperature too high</li> <li>• Overdrying</li> </ul>	<ul style="list-style-type: none"> <li>• Irreversible condition.</li> </ul>	<ul style="list-style-type: none"> <li>• Follow fabric care label directions.</li> <li>• If shrinking is a concern, check load often.</li> <li>• Remove items while slightly damp and hang or lay flat to complete drying.</li> <li>• Block knits into shape.</li> </ul>
Wrinkling	<ul style="list-style-type: none"> <li>• Overloading</li> <li>• Leaving items in dryer after cycle ends</li> </ul>	<ul style="list-style-type: none"> <li>• Reduce load size and tumble at medium or low heat for 5-10 minutes.</li> <li>• Remove items immediately. Hang or fold.</li> </ul>	<ul style="list-style-type: none"> <li>• DO NOT overload dryer.</li> <li>• Remove items as soon as cycle ends.</li> </ul>
Isolated wet spots on fabrics after completed Steam cycle	<ul style="list-style-type: none"> <li>• Low water pressure in home is not sufficient to atomize incoming water during steam cycle</li> </ul>	<ul style="list-style-type: none"> <li>• Check water line pressure.</li> </ul>	<ul style="list-style-type: none"> <li>• Ensure water line pressure is minimum of 20 psi. DO NOT exceed 120 psi.</li> </ul>

# 44 TROUBLESHOOTING

## Before calling

Before calling for service, review this list. It may save both time and expense. The list includes common occurrences that are not the result of defective workmanship or materials in this dryer.

PROBLEM	POSSIBLE CAUSES	SOLUTIONS
Dryer does not start.	<ul style="list-style-type: none"> <li>Electrical power cord is not securely plugged in or plug may be loose.</li> <li>House fuse blown or circuit breaker tripped.</li> <li>Action of pressing start button on "touch screen" style console not recognized.</li> <li>Thermal limiter tripped.</li> <li>Delay time inadvertently activated.</li> <li>Door may be open. Unit will not operate with door open.</li> <li>Difficult load to dry.</li> </ul>	<ul style="list-style-type: none"> <li>Make sure the plug fits tightly in wall outlet.</li> <li>Reset circuit breaker or replace fuse.</li> <li>Make sure electrical line is not overloaded and the dryer is on a separate circuit.</li> <li>Press start button with bare fingertip.</li> <li>Call authorized service person for replacement.</li> <li>Ensure delay time not activated.</li> <li>Ensure door is closed.</li> <li>Select Dry Boost option.</li> </ul>
LED displays "drr".	<ul style="list-style-type: none"> <li>Dryer has been programmed to temporarily perform a repeating demo cycle.</li> </ul>	<ul style="list-style-type: none"> <li>Reset the unit back to factory default settings as described earlier.</li> </ul>
Dryer runs but won't heat.	<ul style="list-style-type: none"> <li>There are 2 house fuses in the dryer circuit. If 1 of the 2 fuses is blown, the drum may turn but the heater will not operate (electric models).</li> <li>Gas supply valve is not open (gas models).</li> <li>Dryer does not have enough air supply to support the burner flame (gas models).</li> <li>LP gas supply tank is empty or there has been a utility interruption of natural gas (gas models).</li> </ul>	<ul style="list-style-type: none"> <li>Replace fuse.</li> <li>Check to make sure supply valve is open. Refer to the <i>installation instructions</i> provided with the dryer.</li> <li>See the <i>Installation sections of this manual</i>.</li> <li>Refill or replace tank. Dryer should heat when utility service is restored.</li> </ul>



PROBLEM	POSSIBLE CAUSES	SOLUTIONS
Drying cycle takes too long, outside of the dryer feels too hot or smells hot.	<ul style="list-style-type: none"> <li>• Lint filter is clogged with lint.</li> <li>• Exhaust duct requirements have not been met.</li> <li>• Electric dryer is connected to a 208 volt circuit.</li> <li>• Drying procedures have not been followed.</li> <li>• Outside exhaust hood or exhaust duct may be clogged or restricted.</li> <li>• High humidity.</li> </ul>	<ul style="list-style-type: none"> <li>• Make sure all lint has been removed from the dryer lint filter before starting each cycle.</li> <li>• Exhaust duct must be at least 4 inches in diameter and made of rigid or semi-rigid metal.</li> <li>• When in place, the duct must not exceed length listed in the <i>installation instructions</i>.</li> <li>• Drying time will be 20% longer than drying on a 240 volt circuit.</li> <li>• See <i>Operating Instructions</i>.</li> <li>• Clean out any obstruction.</li> <li>• Use a dehumidifier near the dryer.</li> </ul>
Excess moisture in drum between cycles.	<ul style="list-style-type: none"> <li>• Exhaust damper stuck open or not present.</li> </ul>	<ul style="list-style-type: none"> <li>• Fix or clean the damper, or install new one.</li> </ul>
Excessive wrinkling.	<ul style="list-style-type: none"> <li>• Dryer is overloaded.</li> <li>• Items left in dryer too long.</li> <li>• Insufficient sorting of items.</li> <li>• Drying temperature too high.</li> <li>• Drying load is very small.</li> </ul>	<ul style="list-style-type: none"> <li>• DO NOT overload. See <i>Operating Instructions</i>.</li> <li>• Remove items as soon as cycle ends.</li> <li>• See <i>Operating Instructions</i>.</li> <li>• Follow fabric care label instructions.</li> <li>• Add two or three larger items.</li> </ul>
Scratching or chipping of the drum finish.	<ul style="list-style-type: none"> <li>• Foreign objects such as coins, pins, clips or buttons are inside the dryer.*</li> <li>• Permanently attached items such as belt buckles, zippers and fasteners may be hitting the inside of the drum.*</li> </ul>	<ul style="list-style-type: none"> <li>• Always remove foreign objects from pockets before laundering. Remove objects from drum and restart dryer.</li> <li>• It may be necessary to sew a scrap of material securely around ornaments before drying to prevent scratching and damage to the dryer.</li> </ul>
<p>* Drum damage caused by foreign objects or permanently attached items is not covered by the warranty.</p>		

# 46 LIMITED WARRANTY

For the applicable warranty period as set forth below, as measured from your original date of purchase, Electrolux will repair or replace any parts of this appliance that prove to be defective in materials or workmanship when such appliance is installed, used and maintained in accordance with the provided instructions.

## Warranty Periods:

- All parts — One year including labor. In addition, your appliance is covered by a one year, parts only, limited warranty. During the 2nd year from your original date of purchase, Electrolux will pay for parts needed for this appliance that have proven to be defective in materials or workmanship when your appliance is installed, used, and maintained in accordance with the provided instructions.

## Exclusions

This warranty does not cover the following:

1. Products with original serial numbers that have been removed, altered or cannot be readily determined.
2. Product that has been transferred from its original owner to another party or removed outside the USA or Canada.
3. Rust on the interior or exterior of the unit
4. Products purchased "as-is" are not covered by this warranty.
5. Products used in a commercial setting.
6. Service calls which DO NOT involve malfunction or defects in materials or workmanship, or for appliances not in ordinary household use or used other than in accordance with the provided instructions.
7. Service calls to correct the installation of your appliance or to instruct you how to use your appliance.
8. Expenses for making the appliance accessible for servicing, such as removal of trim, cupboards, shelves, etc., which are not a part of the appliance when it is shipped from the factory.
9. Service calls to repair or replace appliance light bulbs, air filters, water filters, other consumables, or knobs, handles, or other cosmetic parts.
10. Pickup and delivery costs; your appliance is designed to be repaired in the home.
11. Surcharges including, but not limited to, any after hour, weekend, or holiday service calls, tolls, ferry trip charges, or mileage expense for service calls to remote areas, including the state of Alaska.
12. Damages to the finish of appliance or home incurred during transportation or installation, including but not limited to floors, cabinets, walls, etc.
13. Damages caused by: services performed by unauthorized service companies; use of parts other than genuine Electrolux parts or parts obtained from persons other than authorized service companies; or external causes such as abuse, misuse, inadequate power supply, accidents, fires, or acts of God.

## DISCLAIMER OF IMPLIED WARRANTIES; LIMITATION OF REMEDIES

CUSTOMER'S SOLE AND EXCLUSIVE REMEDY UNDER THIS LIMITED WARRANTY SHALL BE REPAIR OR REPLACEMENT AS PROVIDED HEREIN. **CLAIMS BASED ON IMPLIED WARRANTIES, INCLUDING WARRANTIES OF MERCHANTABILITY OR FITNESS FOR A PARTICULAR PURPOSE, ARE LIMITED TO ONE YEAR OR THE SHORTEST PERIOD ALLOWED BY LAW, BUT NOT LESS THAN ONE YEAR.** ELECTROLUX SHALL NOT BE LIABLE FOR CONSEQUENTIAL OR INCIDENTAL DAMAGES SUCH AS PROPERTY DAMAGE AND INCIDENTAL EXPENSES RESULTING FROM ANY BREACH OF THIS WRITTEN LIMITED WARRANTY OR ANY IMPLIED WARRANTY. SOME STATES AND PROVINCES DO NOT ALLOW THE EXCLUSION OR LIMITATION OF INCIDENTAL OR CONSEQUENTIAL DAMAGES, OR LIMITATIONS ON THE DURATION OF IMPLIED WARRANTIES, SO THESE LIMITATIONS OR EXCLUSIONS MAY NOT APPLY TO YOU. THIS WRITTEN WARRANTY GIVES YOU SPECIFIC LEGAL RIGHTS. YOU MAY ALSO HAVE OTHER RIGHTS THAT VARY FROM STATE TO STATE.

## If You Need Service

Keep your receipt, delivery slip, or some other appropriate payment record to establish the warranty period should service be required. If service is performed, it is in your best interest to obtain and keep all receipts. Service under this warranty must be obtained by contacting Electrolux at the addresses or phone numbers below.

This warranty only applies in the USA, Puerto Rico and Canada. In the USA and Puerto Rico, your appliance is warranted by Electrolux Major Appliances North America, a division of Electrolux Home Products, Inc. In Canada, your appliance is warranted by Electrolux Canada Corp. Electrolux authorizes no person to change or add to any obligations under this warranty. Obligations for service and parts under this warranty must be performed by Electrolux or an authorized service company. Product features or specifications as described or illustrated are subject to change without notice.

USA  
1-877-435-3287

Electrolux Home Products, Inc.,  
North America  
10200 David Taylor Drive  
Charlotte, NC 28262



Canada  
1-800-265-8352

Electrolux Canada Corp.  
5855 Terry Fox Way  
Mississauga, Ontario, Canada  
L5V 3E4



CE

A20448901 (March 2021)



**Use & Care Manual**  
Washing Machine

**EN 2**

**Manuel d'utilisation et d'entretien**  
Machine à laver

**FR 52**

**Manual de uso y cuidado**  
Lavadora

**SP 108**



[electroluxappliances.com/register](http://electroluxappliances.com/register)

 **Electrolux**

# 2

## IMPORTANT SAFETY INFORMATION

### Please read and save this manual

Thank you for choosing Electrolux, our premium brand in home appliances. This *Use & Care Manual* is part of our commitment to customer satisfaction and product quality throughout the service life of your new appliance.

### Keep a record for quick reference

Purchase date

Electrolux serial number

Electrolux model number

Electrolux model series\*

\*The series number can be found within the Model number (example EFLW7637AW=600 series).



#### NOTE

Registering your product with Electrolux enhances our ability to serve you. You can register online at [www.electroluxappliances.com](http://www.electroluxappliances.com), by sending your Product Registration Card in the mail, or PHOTOREGISTER<sup>SM</sup> using a smart phone. See registration card for details.

### Table of contents

Important Safety Information.....	2
Features.....	6
Pre-Installation Requirements.....	7
Installation.....	12
Accessories and Replacement Parts.....	19
Controls and Settings.....	20
Operating Instructions.....	32
Normal Operating Sounds.....	37
Stain Removal Guide.....	38
Care and Cleaning.....	40
Troubleshooting.....	45
Limited Warranty.....	51

### Questions?

For toll free telephone support or online support in the US and Canada contact:

#### U.S.

1-877-4ELECTROLUX (1-877-435-3287)  
[www.electroluxappliances.com](http://www.electroluxappliances.com)

#### Canada

1-800-265-8352  
[www.electroluxappliances.ca](http://www.electroluxappliances.ca)



#### NOTE

The instructions appearing in this *Use & Care Manual* are not meant to cover every possible condition and situation that may occur. Common sense and caution must be practiced when installing, operating and maintaining any appliance.



#### WARNING

For your safety the information in this manual must be followed to minimize the risk of fire or explosion or to prevent property damage, personal injury or loss of life. Do not store or use gasoline or other flammable vapors and liquids in the vicinity of this or any other appliance.

**READ ALL INSTRUCTIONS BEFORE OPERATING THIS WASHER.**  
**SAVE THESE INSTRUCTIONS FOR FUTURE REFERENCE.**

## Important safety instructions

### Safety precautions

DO NOT attempt to install or operate your unit until you have read the safety precautions in this manual. Safety items throughout this manual are labeled with a Danger, Warning, or Caution based on the risk type.



#### DANGER

DANGER indicates an imminently hazardous situation which, if not avoided, will result in death or serious injury.



#### WARNING

WARNING indicates a potentially hazardous situation which, if not avoided, could result in death or serious injury.



#### WARNING

To reduce the risk of fire, electrical shock, or injury to persons when using this washer, comply with the warnings listed below. Failure to comply with these Important Safety Information and warnings could result in property damage, serious personal injury, or death.

### Definitions

 This is the safety alert symbol. It is used to alert you to potential personal injury hazards. Obey all safety messages that follow this symbol to avoid possible injury or death.



#### CAUTION

CAUTION indicates a potentially hazardous situation which, if not avoided, may result in minor or moderate injury.



#### IMPORTANT

IMPORTANT indicates installation, operation or maintenance information which is important but not hazard-related.

### Prevent fire

- DO NOT wash items that have been previously cleaned in, soaked in, or spotted with gasoline, cleaning solvents, kerosene, cooking oils, waxes, or other flammable or explosive substances. DO NOT store these items on or near the washer. These substances give off vapors or chemical reactions that could ignite or explode.
  - DO NOT put oily or greasy rags or clothing on top of the washer. These substances give off vapors that could ignite the materials.
  - DO NOT add gasoline, cleaning solvents, or other flammable or explosive substances to the wash water. These substances give off vapors that could ignite or explode.
  - Under certain conditions, hydrogen gas may be produced in a hot water system that has not been used for 2 weeks or more. HYDROGEN GAS IS EXPLOSIVE.
- If the hot water system has not been used for such a period, before using the washer, turn on all hot water faucets and let the water flow from each for several minutes. This will release any accumulated hydrogen gas. Hydrogen gas is flammable; DO NOT smoke or use an open flame during this time.
- DO NOT store or use gasoline or other flammable vapors or liquids in the vicinity of this or any other appliance.
  - Failure to comply with these warnings could result in fire, explosion, serious bodily injury and/or damage to the rubber or plastic parts of the washer.
  - DO NOT continue to use the washer if you hear squeaking, grinding, rubbing or other unusual noises. This could be a sign of mechanical breakdown and lead to fire or serious injury. Contact a qualified technician immediately.

# 4

## IMPORTANT SAFETY INFORMATION

### Protect children

- DO NOT allow children to play on or in the washer. Close supervision of children is necessary when the washer is used near children. As children grow, teach them the proper, safe use of all appliances.
- Destroy the carton, plastic bag and other packing materials after the washer is unpacked. Children might use them for play. Cartons covered with rugs, bedspreads or plastic sheets can become airtight compartments.
- Keep laundry products out of children's reach. To prevent personal injury, observe all warnings on product labels.
- Before the washer is removed from service or discarded, remove the washer door to prevent accidental entrapment.
- Failure to comply with these warnings could result in serious personal injuries.

### Risk of child entrapment

Child entrapment and suffocation are not problems of the past. Junked or abandoned washers and dryers are still dangerous – even if they will sit for “just a few days”. If you are getting rid of your old washer or dryer, please follow the instructions below to help prevent accidents.

We strongly encourage responsible appliance recycling/disposal methods. Contact your State/Province Energy Office, Local Electric and Water Utilities or Conservation Program Office or visit [www.energystar.gov/recycle](http://www.energystar.gov/recycle) for more information on recycling your old washer or dryer.

### Before you throw away your old washer or dryer:

- Remove doors
- Remove the electric power cord
- Secure all hoses and drain pipes to prevent water from leaking out and creating a slip hazard.

### Prevent injury

- To prevent shock hazard and assure stability during operation, the washer must be installed and electrically grounded by a qualified service person in accordance with local codes. Installation instructions are packed in the washer for installer's reference.

Refer to the Installation sections of this manual for detailed grounding procedures. If the washer is moved to a new location, have it checked and reinstalled by a qualified service person.

- To prevent personal injury or damage to the washer, the electrical power cord of the washer must be plugged into a properly grounded and polarized 3-prong outlet. The third grounding prong must never be removed. Never ground the washer to a gas pipe. DO NOT use an extension cord or an adaptor plug.



### WARNING

#### FIRE/ELECTRICAL SHOCK HAZARD

Avoid fire hazard or electrical shock. DO NOT use an adaptor plug or extension cord or remove grounding prong from electrical power cord. Failure to follow this warning can cause serious injury, fire or death.



### WARNING

Improper grounding of the washer may cause serious injury or death. Check with a licensed electrician if you are in doubt as to whether the appliance is properly grounded.

#### Grounding type wall receptacle

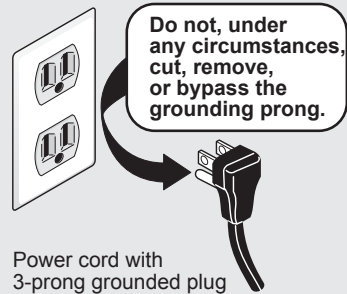

- Follow package directions when using laundry products. Incorrect usage can produce poisonous gas - resulting in serious injury or death.
- DO NOT combine laundry products for use in 1 load unless specified on the label.





## WARNING

### HARMFUL VAPOR HAZARD

DO NOT use or mix liquid chlorine bleach with other household chemicals such as toilet cleaners, rust removers, acids such as vinegar, or products containing ammonia. These mixtures can produce dangerous fumes which can cause serious injury or death.



## WARNING

### RISK OF INJURY

DO NOT WASH: Water resistant and water repellent clothing or other materials. Failure to follow these instructions may result in an abnormal vibrating and out-of-balance condition that could result in physical injury, property damage, and/or appliance damage.



## Prevent injury and damage to the washer

To prevent serious personal injury and damage to the washer:

- All repairs and servicing must be performed by an authorized service technician unless specifically recommended in this *Use & Care Manual*. Use only authorized factory parts.
- DO NOT tamper with controls.
- DO NOT install or store the washer where it will be exposed to the weather.
- DO NOT install on carpet. Install washer on a solid floor. It may be necessary to reinforce the floor to prevent vibration or movement.
- To reduce the risk of electric shock, disconnect this appliance from the power supply before attempting any user maintenance. Turning the controls to the OFF position does not disconnect this appliance from the power supply.
- To prevent injury, DO NOT reach into the washer while parts are moving.
- This washer is equipped with an electrical overload protector. The motor will stop if it becomes overheated.
- Failure to comply with these warnings could result in serious personal injuries.

# 6

## FEATURES

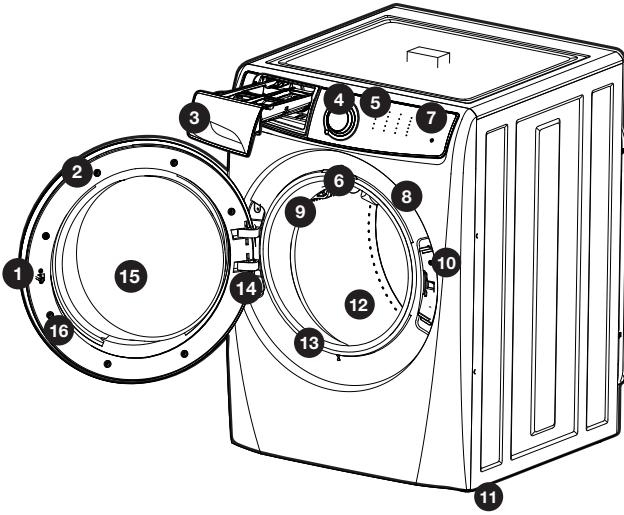

**Not all cycles, options, or features listed are available on every model.**

1. Door striker	9. Cascading wash vanes
2. Reversible door	10. Door latch with safety lock
3. Laundry products dispenser	11. Adjustable leveling legs
4. LED Display	12. Stainless steel wash drum
5. Cycle Display	13. Flexible door gasket
6. Drum light (select models)	14. Wide angle door hinge
7. Control lock	15. Inner bowl with small article redistribution ramp
8. Serial and model #	16. Door stand ventilation

Refer to the table below for an overview of features available for each model series.

	drum light	door reversibility	3 compartment dispenser	Adaptive Dispenser™	detergent pack option	pure rinse	optic whites	hand wash	whitest whites	allergen	sanitize	stain treatment	perfect steam	wrinkle release	fast wash
<b>300 Series</b>	no	yes	yes	no	no	no	no	no	no	no	no	no	no	no	no
<b>400 Series</b>	no	yes	no	yes	yes	no	no	yes	no	yes	yes	yes	yes	yes	18 <sup>min</sup>
<b>500 Series</b>	yes	yes	no	yes	yes	yes	no	no	yes	yes	yes	yes	yes	yes	15 <sup>min</sup>
<b>600 Series</b>	yes	yes	no	yes	yes	yes	yes	yes	no	yes	yes	yes	yes	yes	15 <sup>min</sup>

**✓ Installation Checklist**

**Shipping Hardware**

- Foam shipping support (under wash tub) removed and stored
- Shipping bolts and spacers removed from rear of appliance and stored
- Hole plugs (shipped in manual bag) installed in holes in backsheet

**Leveling**

- Washer is level, side-to-side and front-to-back
- Cabinet is sitting solid on all corners

**Water Supply**

- Use only new hoses and verify rubber sealing washers are installed
- HOT supply is connected to HOT inlet and COLD supply is connected to COLD inlet
- HOT and COLD water supply turned on
- No leaks present at water supply connections or appliance inlet connections - recheck in 24 hours

**Drain**

- Stand pipe or wall drain height minimum 24"
- Verify anti-siphon disc is attached toward end of drain hose
- Drain hose secured in place with cable tie (shipped in drum)

**Door Reversal**

- Follow detailed instructions in this manual
- Test hinge and latch for function

**Electrical Power**

- House power turned on
- Washer plugged in

**Final Checks**

- Installation instructions and Use & Care Manual read thoroughly
- Door locks and water enters drum when cycle starts
- Registration card sent in

**Tools and materials needed for installation:**

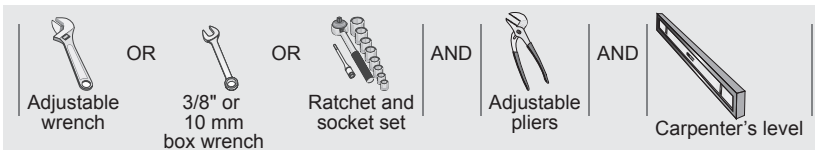

**NOTE**  
Hoses are not included with washer purchase.

**Electrical system requirements**

**CIRCUIT** - Individual, properly polarized and grounded 15 amp. branch circuit fused with 15 amp. time delay fuse or circuit breaker.

**OUTLET RECEPTACLE** - Properly grounded 3-prong receptacle to be located so the power supply cord is accessible when the washer is in an installed position.

**POWER SUPPLY** - 2 wire, with ground, 120 volt single phase, 60 Hz, Alternating Current

# 8

## PRE-INSTALLATION REQUIREMENTS

### NOTE

Because of potentially inconsistent voltage capabilities, the use of this washer with power created by gas powered generators, solar powered generators, wind powered generators or any other generator other than the local utility company is not recommended.

### WARNING

#### ELECTRIC SHOCK HAZARD

Certain internal parts are intentionally not grounded and may present a risk of electrical shock if contacted during installation. Do not contact the following parts while the appliance is energized

- Pump
- Drive motor
- Electrical control boards
- Water valves

### WARNING

#### ELECTRICAL SHOCK HAZARD

Improper connection of the equipment grounding conductor can result in a risk of electrical shock. Check with a licensed electrician if you are in doubt as to whether the appliance is properly grounded.

Grounding type wall receptacle



Do not, under any circumstances, cut, remove, or bypass the grounding prong.

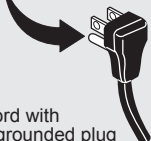

Power cord with 3-prong grounded plug

## Grounding requirements

1. The washer **MUST** be grounded. In the event of malfunction or breakdown, grounding will reduce the risk of electrical shock by a path of least resistance for electrical current.
2. Since your washer is equipped with a power supply cord having an equipment-grounding conductor and a grounding plug, the plug **MUST** be plugged into an appropriate, copper wired receptacle that is properly installed and grounded in accordance with all local codes and ordinances or in the absence of local codes, with the National Electrical Codes, ANSI/NFPA 70 (latest edition), or in Canada, the Canadian electrical code C22.1 part 1. If in doubt, call a licensed electrician. **DO NOT** cut off or alter the grounding prong on the power supply cord. In situations where a two-slot receptacle is present, it is the owner's responsibility to have a licensed electrician replace it with a properly grounded three prong grounding type receptacle.

## Water supply requirements

Hot and cold water faucets **MUST** be installed within hose length of your washer's water inlet. The faucets **MUST** be 3/4 inch (1.9 cm) with threading for laundry hose connection. Water pressure **MUST** be between 20 and 120 psi. Pressure difference between hot and cold cannot be more than 10 psi. Your water department can advise you of your water pressure.

## Drain system requirements

1. Drain capable of eliminating 17 gals (64.3 L) per minute.
2. A standpipe diameter of 1-1/4 in. (3.18 cm) minimum.
3. The standpipe height above the floor :  
Minimum height: 24 in. (61 cm)  
Maximum height: 96 in. (244 cm).

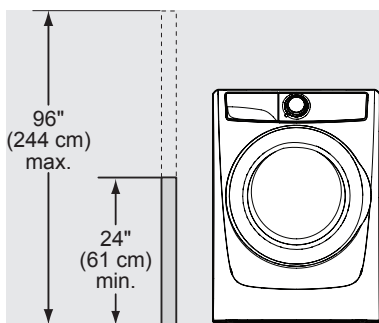

## NOTE

Drain hose length is 59 in. (150 cm). For installations requiring a longer drain hose, use hose P/N 137098000, available from an authorized parts distributor.

## Clearance requirements

### IMPORTANT

#### DO NOT INSTALL YOUR WASHER:

1. In an area exposed to dripping water or outside weather conditions.
2. In an area where gasoline or other flammables are kept or stored.
3. On carpet. Floor **MUST** be solid with a maximum slope of 1 inch (2.5 cm). To minimize vibration or movement, reinforcement of the floor may be necessary.
4. On top of another washer or on top of a dryer. Do not stack a dryer on top of washer already installed on pedestal.

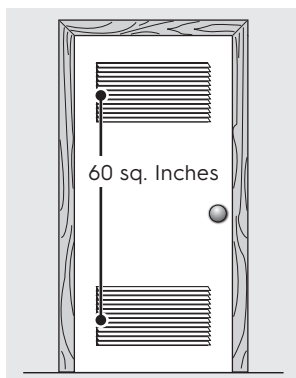

120 sq. Inches Equally Divided Split Vent Door

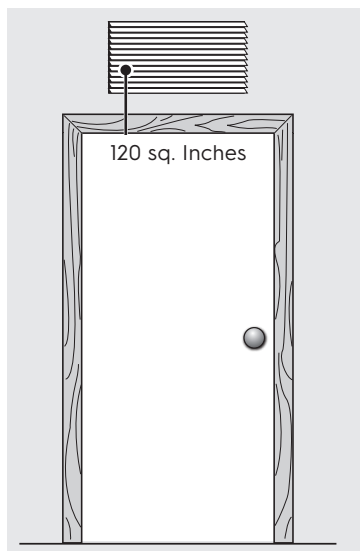

Solid Door with Wall Ventilation

## Installation in a recess or closet

If washer and dryer are installed in the same closet, door ventilation is required: A minimum of 120 square inches (774.2 cm<sup>2</sup>) of opening, equally divided at the top and bottom of the door, is required. Louvered openings should be located 3 inches (7.6 cm) from bottom and top of door. Air openings are required to be unobstructed when a door is installed. A louvered door with equivalent air openings for the full length of the door is acceptable.

# 10

## PRE-INSTALLATION REQUIREMENTS

120 sq. Inches min.  
Louvered Opening

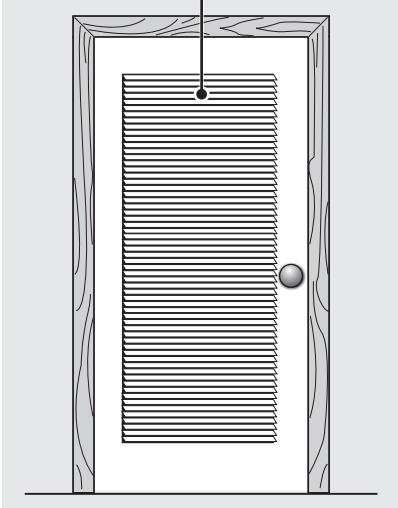

Louvered Door

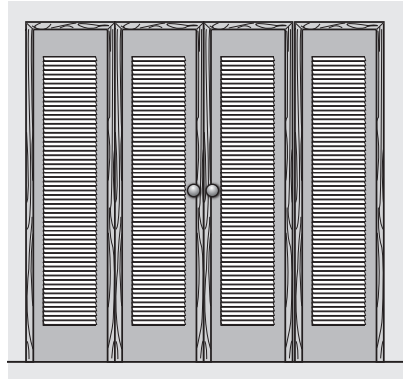

Bi-Fold louvered doors with  
120 sq. in. of ventilation

120 sq. Inches of  
wall venting

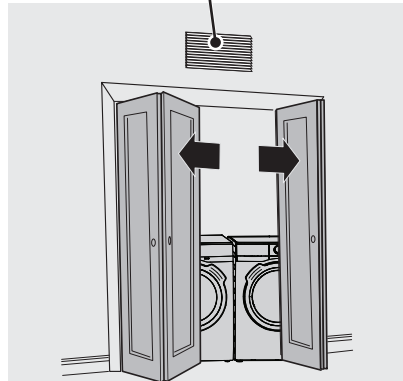

Solid Bi-Fold doors with no  
ventilation

### MIN. INSTALLATION CLEARANCES - Inches (cm)

	Sides	Rear	Top	Front
Alcove/ recess	0" (0 cm)	0" (0 cm)	0" (0 cm)	Open
Closet with door vent	0" (0 cm)	0" (0 cm)	0" (0 cm)	1" (2.5 cm)
Closet with wall vent	1" (2.5 cm)	1" (2.5 cm)	1" (2.5 cm)	1" (2.5 cm)

Washer dimensions

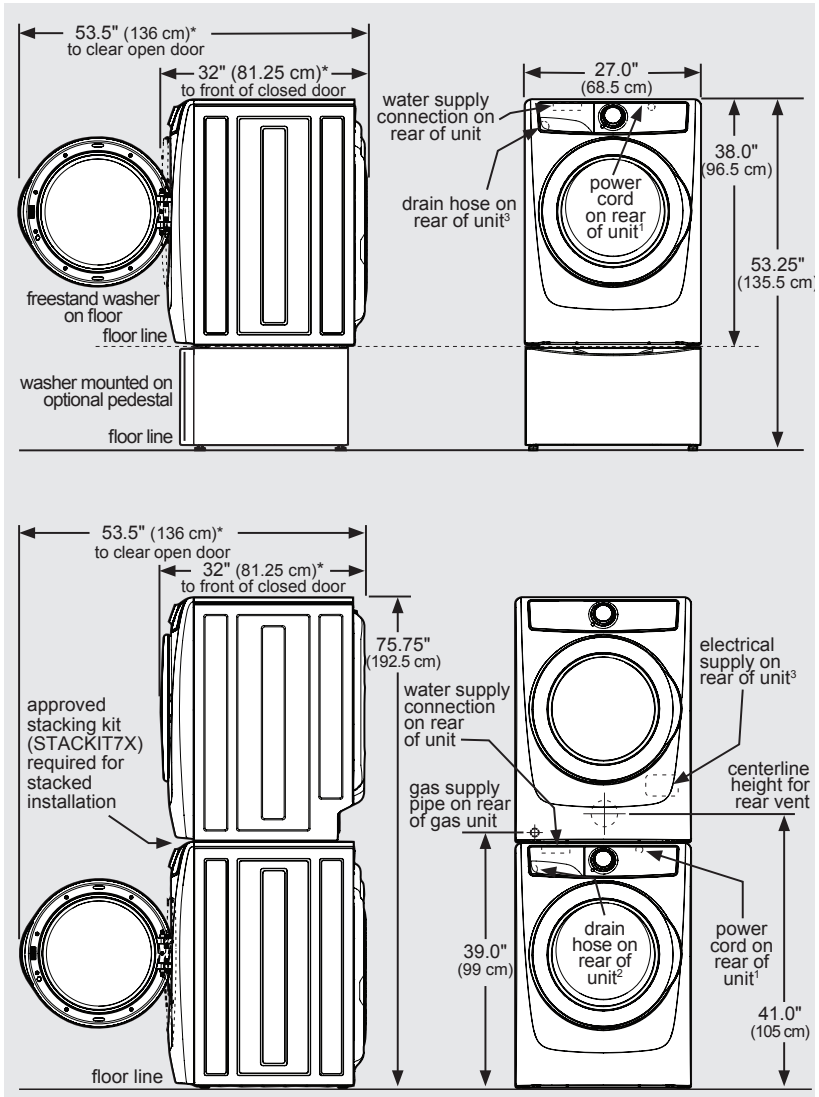

\*Connection of water inlet hose on steam dryer adds 3/4 in. (2 cm) to installation depth.

<sup>1</sup>Power supply cord length on washer approximately 60 inches (152.5 cm).

<sup>2</sup>Drain hose length on washer approximately 59 inches (150 cm).

<sup>3</sup>Power supply cord length on gas dryer or electric Canadian dryer approximately 60 inches (152.5 cm).

# 12 INSTALLATION

## Unpacking the washer



### WARNING

#### ELECTRICAL SHOCK HAZARD

Improper connection of the equipment grounding conductor can result in a risk of electrical shock. Check with a licensed electrician if you are in doubt as to whether the appliance is properly grounded.

1. Temporarily remove door tape.
2. Close door and reapply door tape.
3. Using a rug, blanket or piece of cardboard to protect the floor, carefully lay the washer on its back.

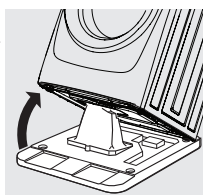

### IMPORTANT

DO NOT place the washer onto its back without the shipping bolts.



### CAUTION

#### EXCESSIVE WEIGHT HAZARD

To avoid back or other injury, have more than one person move or lift the washer.

4. Remove styrofoam base and shipping plug and set them aside.

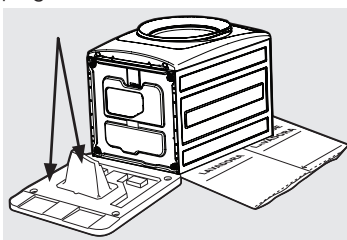

5. Carefully return the washer to an upright position.

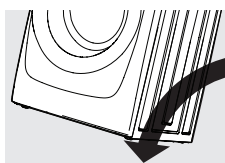

6. Carefully move the washer to within 4 feet (1 m) of its final location.



### WARNING

#### ELECTRICAL SHOCK HAZARD

Improper connection of the equipment grounding conductor can result in a risk of electrical shock. Check with a licensed electrician if you are in doubt as to whether the appliance is properly grounded.



### IMPORTANT

Save styrofoam base and shipping plug for use to help prevent washer damage during any future moves.



### IMPORTANT

DO NOT tip washer upside down onto its top or onto its right side for any reason.

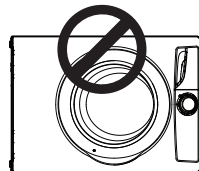
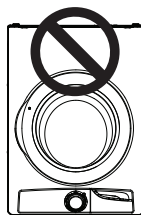



## Removing shipping hardware



### IMPORTANT

Failure to remove shipping hardware completely could result in damage to the appliance, damage to your home, or unexpected washing results.

Save all shipping bolts and spacers for future use. If the washer is to be transported at a later date, the shipping hardware must be reinstalled to help prevent shipping damage

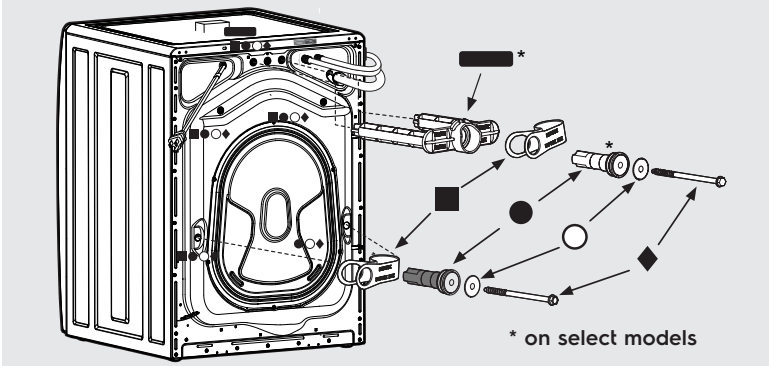

#### For 300 Series:

Remove all of the following:

- ◆ 4 BOLTS
- 4 SHIMS
- 4 BLACK SPACERS
- 3 P CLAMPS

#### For 400, 500, and 600 Series:

Remove all of the following:

- ◆ 5 BOLTS
- 5 SHIMS
- 4 BLACK SPACERS
- 4 P CLAMPS
- 1 WHITE SPACER\*
- ▬ 1 SHIPPING FORK\*



### NOTE

Rubber expansion material on spacers may need time to relax before they can be easily pulled through shipping hole.

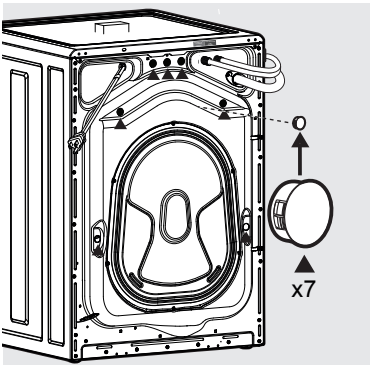

## Installing hole plugs

Locate hole plugs in the small bag supplied with washer instruction manuals. Insert them in the holes in the washer back panel where the shipping hardware has been removed.

# 14 INSTALLATION

## Leveling the washer

Excessive noise and vibration can be prevented by properly leveling the washer.

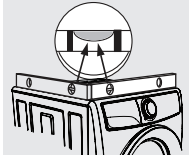
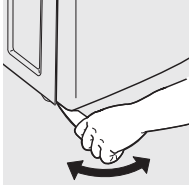
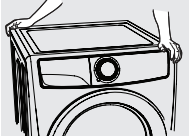
1. For free standing installation and with the washer within 4 feet (1 m) of its final location, place a level on top of the washer.  

2. Use an adjustable wrench to adjust the leveling legs so the washer is level front-to-rear and side-to-side, and stable corner-to-corner.  

3. Press down on alternate corners and sides and feel for the slightest movement. Adjust the appropriate leg(s) so the washer sits solidly on the floor on ALL four legs. Keep the leveling leg extension at a minimum for best performance of the washer.  

### NOTE

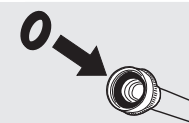
For pedestal installations, see additional installation instructions included with the pedestal.

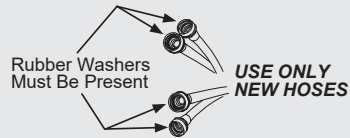
## Connecting the water

1. Run some water from the hot and cold faucets to flush the water lines and remove particles that might clog the water valve screens and to determine which faucet is hot and which is cold supply.  

2. Check to ensure that the inlet hoses have the rubber washer firmly in place.  



### NOTE

Hoses are not included with washer purchase.

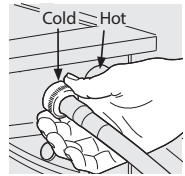
3. Connect the HOT inlet hose (color: red) to the HOT inlet connection on the washer and the COLD inlet hose to the COLD inlet connection (color: blue) on the washer.



**Cold inlet shown on left side (400, 500, 600 models only). On 300 series, the cold inlet is on the right side.**

### IMPORTANT

The cold water inlet will have a blue cap cover on the inlet connection and the hot water inlet will have a red cap cover on the inlet connection. Additionally, depending on the model, the hot and cold inlet connections will be marked with either an adhesive label or markings directly on the unit to indicate which side is cold and which side is hot.

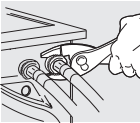
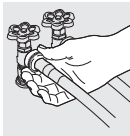
4. Tighten by hand until snug. Then tighten each supply connection another 2/3 turn with pliers. **Do not cross thread or over-tighten these connections.**  

5. Connect the HOT inlet hose to the HOT water supply and the COLD inlet hose to the COLD water supply.  

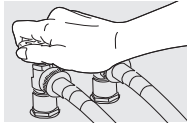
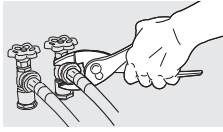
- Tighten by hand until snug. Then tighten each supply connection another 2/3 turn with pliers. **Do not bend, kink or pinch water inlet hoses.**
- Turn on the water and check for leaks.



**NOTE**

The standpipe inside diameter must be 1-1/4" (3.2 cm) minimum. There must be an air gap around the drain hose in the standpipe. A snug hose fit can cause a siphoning action.

**Completing the installation**

- Plug the power cord into a grounded outlet.

**Connecting the drain**

- Verify the anti-siphon disc is in place.
- Form a "U" shape on the end of the drain hose with the hose pointed toward the drain. Place the formed end in a laundry tub or a standpipe and secure the drain hose with the cable tie (provided in the manual bag) to the standpipe, inlet hose, laundry tub, etc. so the hose does not pull out from the force of the water.

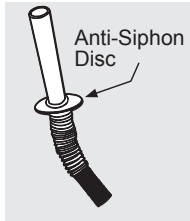

**WARNING**

**ELECTRICAL SHOCK HAZARD**

Improper connection of the equipment grounding conductor can result in a risk of electrical shock. Check with a licensed electrician if you are in doubt as to whether the appliance is properly grounded.

- Turn on the power at a circuit breaker/fuse box.
- Carefully slide the washer to its final position. Recheck for level and rock corners for stability. See *Leveling the washer*. Remove and discard door tape.
- Run the washer through a complete cycle, checking for water leaks and proper operation.
- If you have any questions during initial operation, please review the *Troubleshooting* section before calling for service.
- Place these instructions in a location near the washer for future reference.

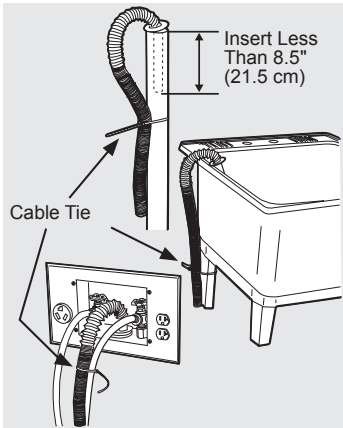

**NOTE**

A wiring diagram and technical data sheet are located under the washer top panel, on top of the detergent dispenser housing.

**IMPORTANT**

Check to ensure the power is off at a circuit breaker/fuse box before plugging the power cord into an outlet.

# 16 INSTALLATION

## Reversing the door

### NOTE

Door reversibility is available on all models.

### IMPORTANT

#### BEFORE YOU REVERSE WASHER DOOR:

1. Be sure you have adequate swing area before reversing door.
2. Gather your tools - including a screw driver with a #2 square bit and plastic knife (or small, flat prying tool that won't damage paint).
3. Protect flat work surface, such as top of washer or floor near washer, with a soft cloth or towel.
4. Be sure washer is unplugged from power source!

#### Tools needed for reversal:

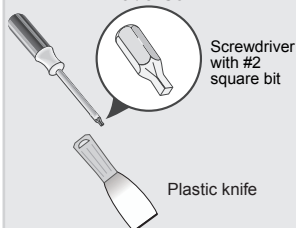

### WARNING

#### ELECTRICAL SHOCK HAZARD

Failure to disconnect power source before servicing could result in personal injury or even death.

## Removing door assembly

1. Completely open the door to expose all four hinge screws.
2. Remove all four hinge screws with #2 square bit driver. Save for reinstalling later.

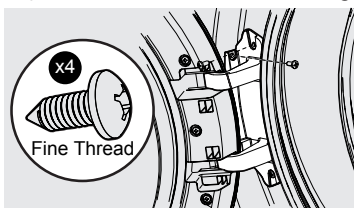

3. Hold the door with one hand supporting the handle area and one hand supporting the hinge. While supporting the door at the hinge, press firmly with the other hand until the locating pins on the back of the hinge plate dislocate from the front panel.

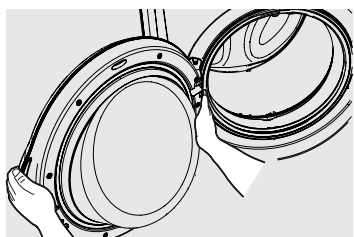

4. While supporting the door with one hand, pinch the tabs to release the plastic terminal cap from the hinge plate.

### IMPORTANT

Take care not to pull the door away from the washer until you remove the wiring harness terminal cap.

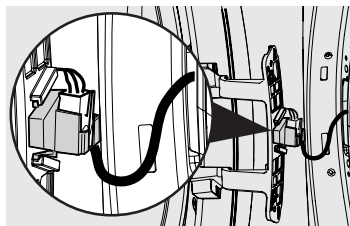

5. Set the door face down on a flat surface protected by soft cloth or towel.

6. Release wiring harness from retainer on plastic terminal cap. Then release terminal from terminal cap. Save the cap to reinstall later.

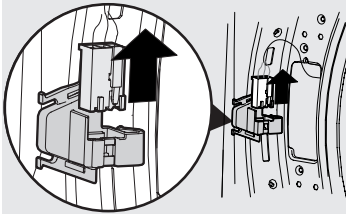

**Removing door lock and plastic hole cover**

1. Locate and remove both screws from door lock. Save screws for later.
2. Rotate the lock as you pull it out through the front panel. Take care not to pull too hard or too far as the lock is still attached to the wiring harness.

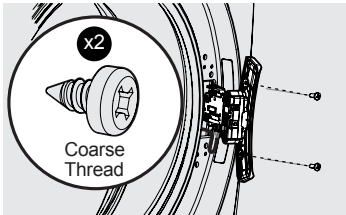

3. Disconnect the wiring harness terminal from the door lock. Set the door lock aside for reinstallation later.
4. Pry the bottom of the plastic hole cover upward to release it from the front panel. You may have to use a non-scratching plastic knife if you are unable to release it manually. Then, slide the cover down slightly and remove it from the front panel.

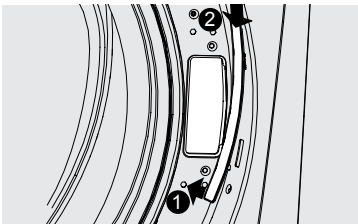

**Reinstalling door lock and hole cover**

1. Move the plastic cover to the other side of the front panel. Position the cover so the "hook" is at the bottom. Insert hook into lower slot, slide the cover down, and press upper retention tabs into opening until they snap into place.

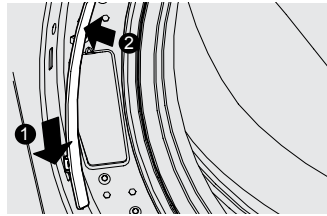

2. Insert wiring harness into door lock.
3. Insert door lock into front panel and reinstall door lock screws.

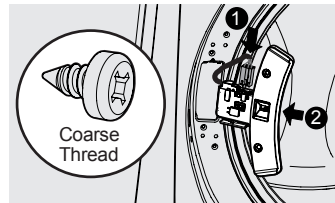

**Reversing door assembly**

1. Locate nine screws on inner door ring. Remove each and save for reinstallation later. Remove inner door (with hinge) and carefully set aside.

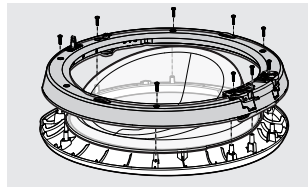

2. Lift door bowl slightly and rotate 180 degrees, setting it back onto outer door.

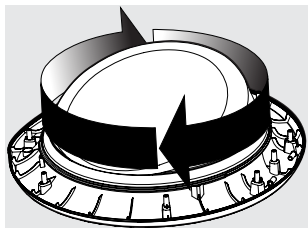

# 18 INSTALLATION

3. Make sure the alignment tabs reengage.

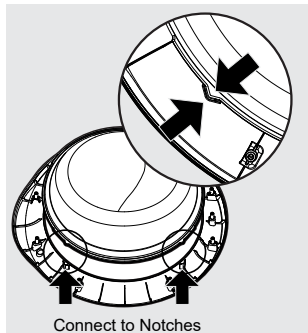

4. Reattach the inner door to the outer door using the nine screws removed earlier. See illustration, Step 1.
5. Check to verify that the scoop (wider section) of the door bowl is situated at the BOTTOM of the door.

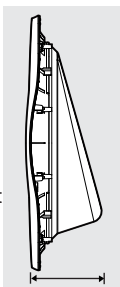

3. Insert hinge locating pins into the hole that were previously covered by the plastic hole cover. Press on the face of the hinge to snap the other locating pins into place.

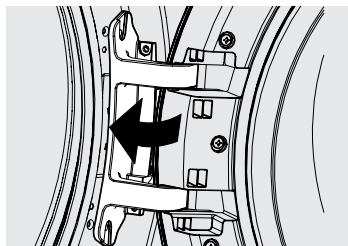

4. Reinstall all four screws removed earlier - two front screws first, then two side screws.

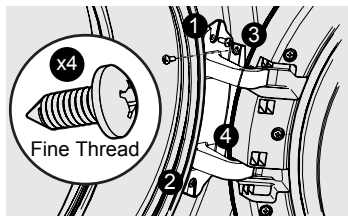

## Reinstalling door assembly

1. Insert the wiring harness terminal into the terminal cap and wrap the harness into the harness retainer.

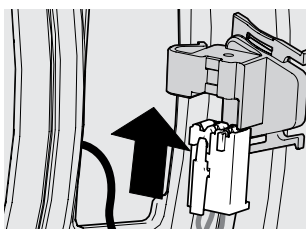

2. Slide terminal cap onto back of hinge plate until tabs snap into place.

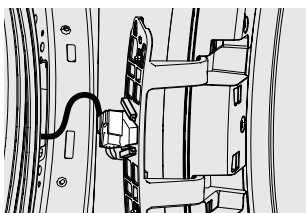

## Verify reversed door operation

1. Test door for free, smooth swinging operation and secure latching when closed.
2. Verify inner door bowl is in the correct orientation with the "scoop" at the bottom.

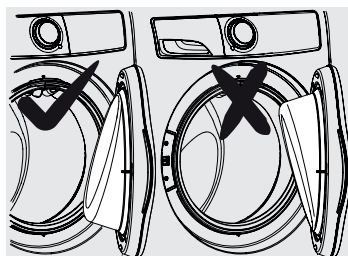

3. Plug in washer and close the door. Test correct door lock operation by starting a test cycle: lock should engage, and door should not be able to be opened until cycle is paused or canceled.

## Accessories

### MATCHING STORAGE PEDESTAL\*

White Pedestal - P/N EPWD257UIW

Titanium Pedestal - P/N EPWD257UTT

A storage pedestal accessory, specifically designed for this washer may be used to elevate the washer for ease of use. This pedestal will add about 15" (38 cm) to the height of your unit.

\*Other colors may be available. Contact the source where you purchased your washer.

### DRYER STACKING KIT P/N STACKIT7X

Depending on the model purchased, a kit for stacking a matching dryer on top of this washer may have been included in the initial purchase of your dryer. If your model did not include a stacking kit or you desire another stacking kit, you may order one.

### INLET HOSE KITS

Please call 866-233-8353 (in Canada, 800-265-8352) to explore hose kit options that will meet your specific installation needs.

### DRAIN HOSE EXTENSION KIT P/N 137098000

In order to reach standpipe heights or distances beyond the reach of the drain hose supplied, order the Drain Hose Extension Kit.

### UNIVERSAL APPLIANCE WRENCH P/N 137019200

A Universal Appliance Wrench is available to aid in dryer/washer/pedestal feet adjustment.

### TOUCH UP PAINT PENS\*

White - P/N 5304468812

Titanium - P/N 5304475700

\*Other colors may be available. Contact the source where you purchased your washer.



### CAUTION

Failure to use accessories manufactured by (or approved by) the manufacturer could result in personal injury, property damage or damage to the washer.

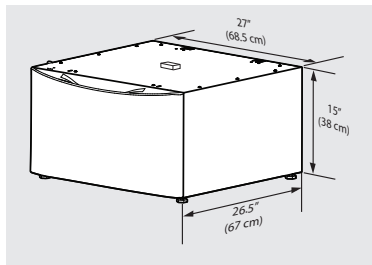

Storage Pedestal

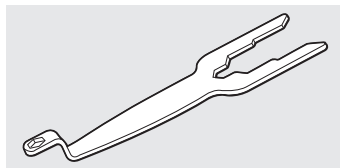

Universal Appliance Wrench

## Replacement parts in U.S. and Canada:

If replacements parts are needed for your dryer, you can contact the source where you purchased your dryer, call 1-877-4ELECTROLUX (1-877-435-3287) in the U.S. or 1-800-265-8352 in Canada, or visit our website, [www.electroluxappliances.com](http://www.electroluxappliances.com) in the U.S. or [www.electroluxappliances.ca](http://www.electroluxappliances.ca) in Canada for the Electrolux Authorized Parts Distributor nearest you.

# 20 CONTROLS AND SETTINGS

## Model series

### 300 SERIES

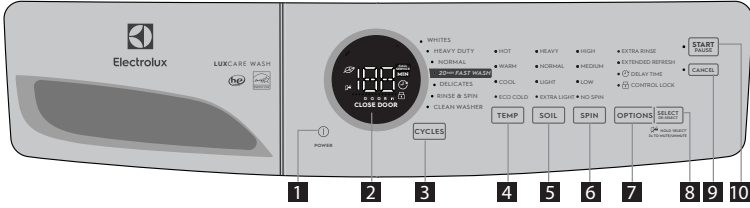

### 400 SERIES

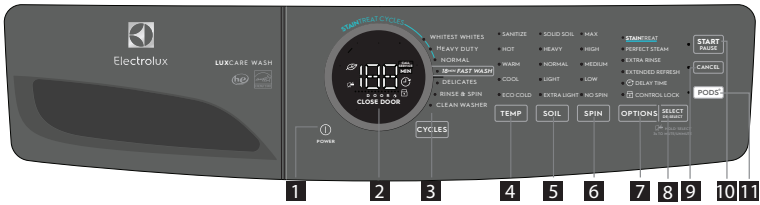

### 500 SERIES

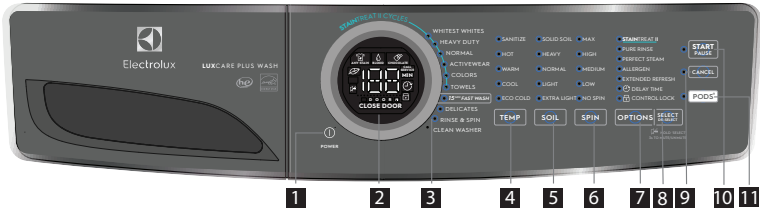

### 600 SERIES

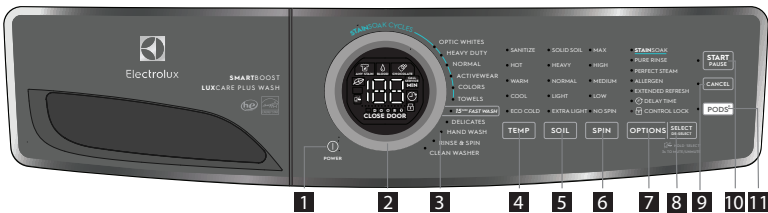

- |                  |               |              |                          |
|------------------|---------------|--------------|--------------------------|
| 1 power          | 4 temperature | 7 options    | 10 start                 |
| 2 cycle selector | 5 soil level  | 8 set/select | 11 PODS® (select models) |
| 3 LED display    | 6 spin speed  | 9 cancel     |                          |

*This manual covers many models and not all cycles, options, or features listed are available on every model. Consoles shown above for reference only. Your model may differ.*

PODS® is a registered trademark of Procter & Gamble Company, Cincinnati OH, used under license by Electrolux.



## Settings chart - 300 series washer



These temperature, spin speeds, soil levels and options are available with the following cycles:

		CYCLE SELECTIONS								
		WHITES	HEAVY DUTY	NORMAL	20 MIN FAST WASH	DELICATES	RINSE & SPIN	CLEAN WASHER		
CYCLE SETTINGS	<b>TEMP</b>								<b>NO OPTIONS AVAILABLE WITH THIS CYCLE. DO NOT LOAD ANY ITEMS IN DRUM DURING SYSTEM CLEAN CYCLE.</b>	
	HOT	✓	✓	✓						
	WARM	✓	✓	✓	✓	✓				
	COOL	✓	✓	✓	✓	✓				
	ECO COLD	✓	✓	✓			✓	✓		
	<b>SOIL</b>									
	HEAVY	✓	✓	✓						
	NORMAL	✓	✓	✓		✓				
	LIGHT			✓	✓	✓				
	EXTRA LIGHT			✓	✓	✓				
	<b>SPIN</b>									
	HIGH	✓	✓	✓	■			✓		
	MEDIUM	✓	✓	✓		✓	✓	✓		
	LOW	✓		✓		✓	✓	✓		
	NO SPIN	✓		✓		✓	✓	✓		
	<b>OPTIONS</b>									
EXTRA RINSE	✓	✓	✓		✓	✓	✓			
EXTENDED REFRESH	✓	✓	✓		✓					
DELAY START	✓	✓	✓	✓	✓	✓	✓			
CONTROL LOCK	✓	✓	✓	✓	✓	✓	✓			
MUTE/UNMUTE	✓	✓	✓	✓	✓	✓	✓			

✓ = Available selections. ◻ = Factory presets. ◼ = Non-modifiable presets.

# 22 CONTROLS AND SETTINGS

## Settings chart - 400 series washer



These temperature, spin speeds, soil levels and options are available with the following cycles:

### CYCLE SELECTIONS

	WHITEST WHITES	HEAVY DUTY	NORMAL	18 MIN FAST WASH	DELICATES	RINSE & SPIN	CLEAN WASHER
--	----------------	------------	--------	------------------	-----------	--------------	--------------

#### TEMP

SANITIZE	✓	✓	✓				
HOT	✓	✓					
WARM	✓	✓	✓	✓	✓		
COOL	✓	✓	✓	✓	✓		
ECO COLD	✓	✓	✓			✓	

#### SOIL

SOLID SOIL	✓	✓	✓				
HEAVY	✓	✓	✓				
NORMAL	✓	✓	✓		✓		
LIGHT			✓	✓	✓		
EXTRA LIGHT			✓	✓	✓		

#### SPIN

MAX	✓	✓	✓	■		✓	
HIGH	✓	✓	✓			✓	
MEDIUM	✓	✓	✓		✓	✓	
LOW	✓		✓		✓	✓	
NO SPIN	✓		✓		✓	✓	

#### OPTIONS

STAIN TREAT	✓	✓	✓				
PERFECT STEAM	✓	✓	✓				
EXTRA RINSE	✓	✓	✓		✓	✓	
EXTENDED REFRESH	✓	✓	✓		✓		
DELAY START	✓	✓	✓	✓	✓	✓	
CONTROL LOCK	✓	✓	✓	✓	✓	✓	✓
MUTE/UNMUTE	✓	✓	✓	✓	✓	✓	✓
PODS®	✓	✓	✓	✓	✓		✓

NO OPTIONS AVAILABLE WITH THIS CYCLE. DO NOT LOAD ANY ITEMS IN DRUM DURING SYSTEM CLEAN CYCLE.

✓ = Available selections. ◻ = Factory presets. ■ = Non-modifiable presets.

PODS® is a registered trademark of Procter & Gamble Company, Cincinnati OH, used under license by Electrolux.

## Settings chart - 500 series washer



These temperature, spin speeds, soil levels and options are available with the following cycles:

		CYCLE SELECTIONS									
		WHITEST WHITES	HEAVY DUTY	NORMAL	ACTIVE WEAR	COLORS	TOWELS	15 MIN FAST WASH	DELICATES	RINSE & SPIN	CLEAN WASHER
CYCLE SETTINGS	<b>TEMP</b>										
	SANITIZE	✓	✓	✓			✓				
	HOT	✓	✓	✓			✓				
	WARM	✓	✓	✓	✓	✓	✓	✓	✓		
	COOL	✓	✓	✓	✓	✓	✓	✓	✓		
	ECO COLD	✓	✓	✓	✓	✓	✓	✓	✓	✓	
	<b>SOIL</b>										
	SOLID SOIL	✓	✓	✓	✓	✓	✓				
	HEAVY	✓	✓	✓	✓	✓	✓				
	NORMAL	✓	✓	✓	✓	✓	✓				
	LIGHT	✓	✓	✓	✓	✓	✓			✓	
	EXTRA LIGHT			✓	✓	✓		✓		✓	
	<b>SPIN</b>										
	MAX	✓	✓	✓	✓	✓	✓	✓			✓
	HIGH	✓	✓	✓	✓	✓	✓				✓
	MEDIUM	✓	✓	✓	✓	✓	✓			✓	✓
	LOW	✓	✓	✓	✓	✓	✓			✓	✓
NO SPIN	✓	✓	✓	✓	✓				✓	✓	
CYCLE OPTIONS	<b>OPTIONS</b>										
	STAIN TREAT II	✓	✓	✓	✓	✓	✓				
	PURE RINSE	✓	✓	✓	✓	✓	✓		✓	✓	
	PERFECT STEAM	✓	✓	✓	✓	✓	✓	✓			
	ALLERGEN	✓	✓				✓				
	EXTENDED REFRESH	✓	✓	✓	✓	✓	✓				
	DELAY TIME	✓	✓	✓	✓	✓	✓	✓	✓	✓	
	CONTROL LOCK	✓	✓	✓	✓	✓	✓	✓	✓	✓	✓
	MUTE/UNMUTE	✓	✓	✓	✓	✓	✓	✓	✓	✓	✓
	PODS®	✓	✓	✓	✓	✓	✓	✓	✓	✓	✓

NO OPTIONS AVAILABLE WITH THIS CYCLE. DO NOT LOAD ANY ITEMS IN DRUM DURING SYSTEM CLEAN CYCLE.

✓ = Available selections. ◻ = Factory presets. ◼ = Non-modifiable presets.

# 24 CONTROLS AND SETTINGS

## Settings chart - 600 series washer



These temperature, spin speeds, soil levels and options are available with the following cycles:

### CYCLE SELECTIONS

OPTIC WHITES	HEAVY DUTY	NORMAL	ACTIVEWEAR	COLORS	TOWELS	15 MIN FAST WASH	DELICATES	HAND WASH	RINSE & SPIN	CLEAN WASHER
--------------	------------	--------	------------	--------	--------	------------------	-----------	-----------	--------------	--------------

### TEMP

SANITIZE	✓	✓	✓			✓				
HOT	✓	✓	✓			✓				
WARM	✓	✓	✓	✓	✓	✓	✓	✓		
COOL	✓	✓	✓	✓	✓	✓	✓	✓	✓	
ECO COLD	✓	✓	✓	✓	✓	✓	✓	✓	✓	✓

### SOIL

SOLID SOIL	✓	✓	✓	✓	✓	✓				
HEAVY	✓	✓	✓	✓	✓	✓				
NORMAL	✓	✓	✓	✓	✓	✓				
LIGHT	✓	✓	✓	✓	✓	✓		✓	✓	
EXTRA LIGHT			✓	✓	✓		✓	✓	✓	

### SPIN

MAX	✓	✓	✓	✓	✓	✓	■			✓
HIGH	✓	✓	✓	✓	✓	✓				✓
MEDIUM	✓	✓	✓	✓	✓	✓		✓	✓	✓
LOW	✓		✓	✓	✓	✓		✓	✓	✓
NO SPIN	✓		✓	✓	✓			✓	✓	✓

### OPTIONS

STAINSOAK	✓	✓	✓	✓	✓	✓				
PURE RINSE	✓	✓	✓	✓	✓	✓	✓		✓	
PERFECT STEAM	✓	✓	✓	✓	✓	✓				
ALLERGEN	✓	✓				✓				
EXTENDED REFRESH	✓	✓	✓	✓	✓	✓				
DELAY TIME	✓	✓	✓	✓	✓	✓	✓	✓	✓	✓
CONTROL LOCK	✓	✓	✓	✓	✓	✓	✓	✓	✓	✓
MUTE/UNMUTE	✓	✓	✓	✓	✓	✓	✓	✓	✓	✓
PODS®	✓	✓	✓	✓	✓	✓	✓	✓	✓	✓

NO OPTIONS AVAILABLE WITH THIS CYCLE. DO NOT LOAD ANY ITEMS IN DRUM DURING SYSTEM CLEAN CYCLE.

✓ = Available selections. ◻ = Factory presets. ◼ = Non-modifiable presets.

PODS® is a registered trademark of Procter & Gamble Company, Cincinnati OH, used under license by Electrolux.

## Cycle selection

Press the **power** button to turn on the unit. Then, turn the cycle selector in either direction or press the cycles button (dependent on model) to scroll to the desired cycle. The indicator light for that cycle will be illuminated.

The estimated cycle time will appear on the LED display and indicator lights adjacent to the default settings (water temperature, final spin speed, and soil level) will illuminate for the cycle selected. See *Washer Settings Chart* for default settings for each cycle.

Cycle settings and cycle options can be changed using the **temp**, **spin** and **soil** buttons. See *Cycle Settings* and *Cycle Options* for detailed directions and descriptions of available settings.

To change the cycle once the cycle has begun, press **cancel**, select a new cycle, and press **start** again.

To stop the cycle, press **cancel**.

### NOTE

Using PODS® setting may increase **fast wash** time by several minutes.

### NOTE

For **spin only** cycle deselect **extra rinse**.  
For **drain only** cycle select **no spin**.

See *Cycle Options* for rinse options and *Cycle Settings* for spin settings.

### NOTE

Turning the cycle selector knob without canceling the cycle first, will not change the cycle.



### For best results

Follow the fabric care label instructions on items to be washed.



# 26 CONTROLS AND SETTINGS

## Cycles

LOAD	LOAD TYPE	CYCLE DESCRIPTION
<b>OPTIC WHITES</b>	White loads	<ul style="list-style-type: none"> <li>• SmartBoost action</li> <li>• longer agitation</li> <li>• optimized temperatures</li> </ul>
<b>WHITEST WHITES</b>	White loads	<ul style="list-style-type: none"> <li>• longer agitation</li> <li>• higher temperatures</li> </ul>
<b>WHITES</b>	White loads	<ul style="list-style-type: none"> <li>• longer agitation</li> </ul>
<b>HEAVY DUTY</b>	Large heavily soiled loads	<ul style="list-style-type: none"> <li>• longer agitation</li> <li>• aggressive cleaning motion</li> <li>• higher temperatures</li> </ul>
<b>NORMAL</b>	Mixed loads, cotton	<ul style="list-style-type: none"> <li>• moderate agitation</li> <li>• moderate cleaning motion</li> <li>• most energy efficient</li> </ul>
<b>ACTIVEWEAR</b>	Highly solid lightweight synthetic apparel	<ul style="list-style-type: none"> <li>• longer agitation</li> <li>• mild cleaning motion</li> <li>• extra rinse</li> </ul>
<b>COLORS</b>	Lightly soiled dark or dyed fabrics	<ul style="list-style-type: none"> <li>• mild cleaning motion</li> <li>• lower temperatures</li> </ul>
<b>TOWELS</b>	Towels	<ul style="list-style-type: none"> <li>• long agitation</li> <li>• higher temperatures</li> </ul>
<b>FAST WASH</b> (varies by model) <b>15/18/20 min.</b>	Small lightly soiled loads (3-5 pieces)	<ul style="list-style-type: none"> <li>• aggressive cleaning motion</li> <li>• extra rinse</li> </ul>
<b>DELICATES</b>	Small lightly soiled loads (delicate fabrics)	<ul style="list-style-type: none"> <li>• shorter agitation</li> <li>• gentle cleaning motion</li> <li>• lower temperatures</li> <li>• lower spin speeds</li> </ul>
<b>HAND WASH</b>	Small, lightly soiled loads and very delicate fabrics	<ul style="list-style-type: none"> <li>• very short agitation</li> <li>• long soaking times</li> <li>• lower temps</li> <li>• lower spin speeds</li> </ul>
<b>RINSE &amp; SPIN</b>	Rinse and spin only (cold rinse or add fabric softener)	<ul style="list-style-type: none"> <li>• cold temperature</li> </ul>
<b>CLEAN WASHER</b>	See "Care and Cleaning" section of the manual	

\*All cycles not available on every model. See Page 19.

## Cycle settings

### Washing temperature

The appropriate washing temperature will automatically be indicated for the cycle selected. To change the preset temperature, press the **temp** button to scroll

to the desired setting. Select a wash water temperature according to fiber content, colorfastness and soil level.

To protect your fabrics, not all temperatures are available with every cycle. If a temperature is not appropriate for the cycle, it cannot be selected and will not be lit by pressing the **temp** button.

The temperature selected for the cycle will be remembered and recalled each time that cycle is selected in the future.

All wash water temperatures are automatically regulated to maximize detergent effectiveness and improve washing performance. The water heater setting and its distance from the washer, water usage in other parts of the home, and seasonally low ground water temperature in some geographic areas can affect water temperature.

### sanitize (on select models)

Use the sanitize setting to clean and sanitize heavily soiled, colorfast fabrics including towels, bedding, cloth diapers, and children's clothing.

It is recommended that you set your water heater to 120°F (49°C) or higher to ensure proper performance during this cycle. If the setting is lower or the load is extra large, the cycle time may be extended.

When used with the **heavy duty, towels, optic whites** and **whitest whites**, cycles, the **sanitize** setting will kill 99.9% of bacteria with no carryover of bacteria between loads. No bleach or harsh chemicals are needed, but higher temperatures are required. Please check fabric care labels to prevent damage.

### NOTE

The **heavy duty, towels, optic whites** and **whitest whites** with **sanitize** setting cycles have been designed to meet the requirements of NSF P172 protocol for sanitization efficacy.

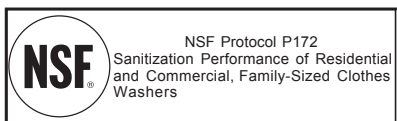

### NOTE

If the voltage at your outlet is under 110v, the internal heater may not adequately heat the wash water. If the cycle is interrupted while the water is heating, the final temperature of the wash water may be lower and sanitation may be reduced.

The wash water is heated by an internal boost heater to a maximum of 152°F (67°C) as the load tumbles. Cold water is added to cool down the load prior to drain and spin.

As a precaution, the washer door remains locked when the water temperature reaches 130°F (55°C)

### NOTE

If the wash cycle is paused or canceled while the internal drum temperature is above 130°F (55°C), the door will remain locked until it cools. You may manually perform a rinse & spin cycle to cool the internal temperature sooner.

### allergen (on select models)

Removes dust mites and dander from household objects. The temperature does increase on this setting.

### NOTE

The **heavy duty, optic whites and towels** cycles with the **allergen** option selected have been designed to meet the requirements of the NSF P351 protocol for allergen reduction efficacy. These cycles and settings will kill dust mites and eliminate at least 95% of pet dander. Since higher temperatures are required, please check fabric care labels to prevent damage.

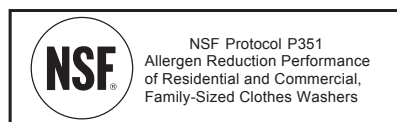

### hot

Use this setting for heavily soiled white or colorfast cottons and blends.

### warm

Use this setting for normally soiled white or colorfast cottons or blends.

### cool

Some warm water will automatically blend with cold tap supply to achieve a precise cold. Use this setting for lightly soiled non-colorfast items, knits, delicates, and hand washables.

### eco cold (on select models)

Wash and rinse temperatures are equivalent to temperature of cold tap supply. Use this selection for fabrics and colors that are prone to dye transfer. For use with cold water detergents.

# 28 CONTROLS AND SETTINGS

## NOTE

The washer will ALWAYS use a small amount of HOT water to dissolve the pack when the **PODS**® option has been selected.

## NOTE

If changes to the settings or options are attempted after the cycle starts, you will hear several beeps when the buttons are pressed. To change settings or options, press **start/pause**, make the new selections and press **start/pause** again.

## Soil level

Adjust the wash time based on the soil level of each load. **Solid soil** (on select models), **heavy, normal, light** and **extra light** (on some models) soil levels are available.

## Spin speed

**Max** (on select models), **high, medium** and **low** (on some models) spin speeds are available for each cycle. The spin speed and/or duration of final spin vary from model to model and cycle to cycle.

Increasing the spin speed will extract more water, decrease drying time and conserve energy. Decreasing the spin speed will reduce wrinkling.

Select **low** spin speed (on some models) to gently spin items that should be line dried.

Use **no spin** to omit the final spin at the end of the cycle. The load will be very wet. Remove items from the wash drum to drip dry or select a spin only cycle to remove excess water at a more convenient time.

## Cycle options

The default options for each cycle will automatically be chosen when a cycle is selected. To protect fabrics, not all options are available for all cycles. If an option is not available for a cycle, the indicator will not light.

## Selecting options

Press the **option** button to scroll through the options until the indicator light for the desired option flashes, then press **select**. The indicator light will illuminate when the option has been selected. Follow the same steps to deselect an option. The indicator light will turn off when the option is deselected.

All settings or options selected for the cycle, except **sanitize** (on select models), **perfect steam**™ (on select models), and stain treatment options, will be remembered and recalled each time that cycle is selected in the future. To return to factory settings, press and hold **soil** and **options** buttons at the same time and hold for **3** seconds until the confirmation signal sounds. To prevent unintentional and accidental exposure of delicate material to excess heat or unexpected steam, the **sanitize, perfect steam**™ and all stain treatment options will need to be reselected each time.

## Stain treatment options (on select models)



Your washer is equipped with powerful stain treatment tools. Depending on your model, use one of the options below to deal with tough stains on your garments. See step 5 in the *Operating Your Washer* section in this manual for details on adding stain additives to the dispenser.

### StainTreat (400 series washer)

Select this option to add a short initial wash period to available cycles using the stain treatment additives in the **stain soak/treat** compartment. After the stain wash phase, the load will automatically advance to the main wash cycle.

### StainTreatII (500 series washer)

Select this option when available and rotate the cycle selector to rotate through the stain types below. Stain treatment and main detergent will recirculate in the agitating load for approximately 20 minutes and then the washer will advance to the main wash cycle.

- **Any Stain**   
Recirculating wash solution will be heated by boost heater.
- **Blood**   
Recirculating wash solution will NOT be heated by boost heater to prevent setting blood stains.





- **Chocolate** 

Stain wash time is extended with additional heating by boost heater.

### StainSoak (600 series washer)

Similar to **StainTreatII** above with the added feature of detergent/treatment mixing with **SmartBoost** pump technology before the **Stain** washing phase.

### **perfect steam™ (on select models)**

Select this option to add approximately 20 minutes of tumbling in steam.



### NOTE

- Steam may not necessarily be visible inside drum during a steam wash cycle.
- Steam may not be present during entire steam wash cycle.



### IMPORTANT

- If steam is selected, rinse temperatures will be elevated.
- If the wash cycle is paused or cancelled during a steam cycle, the door will remain locked until it cools. You may manually perform a rinse & spin cycle to cool the internal temperature sooner.
- During a steam cycle, steam exiting from the rear vent of the washer is normal and not cause for alarm.

## Wash cycle options

### extra rinse (on select models)

Use this option when additional rinsing is desired to remove excess dirt and detergent. It is recommended for heavily soiled loads or if household members have sensitive skin.

### pure rinse (on select models)

Use this option to reduce detergent residues and fragrances that can irritate skin which rinses cleaner than the extra rinse cycle.

### wrinkle release (on select models)

After the final spin, the washer will perform a "dry" agitation to loosen the garments from the side of the drum.

### extended refresh (on select models)

Select **extended refresh** if you will be unable to remove the load right after the cycle is complete. The washer recognizes the load has sat too long and will do a rinse and spin to keep the load fresh for up to 12 hours. When you are ready to remove the load during the **extended refresh** segment, you must press **cancel** to end the cycle and open the door.

### PODS® (on select models)

Select this option when using a detergent pack in a model equipped with a **PODS®** button (on select dispenser only). This option will divert the flow of water to the detergent pack compartment optimizing the detergent pack performance.

## Control options

### control lock

To lock the controls between cycles, scroll to the control lock option and press **select**. The control lock icon will show on the LED display. To unlock the controls scroll to the control lock option again and press **select**. Use this feature to reduce the likelihood of accidental operation by children. **Washer cycles will not run when control lock is activated.**

### delay time

Use **delay time**  to delay the start of the washing cycle from 30 minutes to 12 hours. To turn on the delay time option, press **options** to scroll to the **delay time** icon and press **select**. Use the **cycles** button (300/400 models) or turn the cycle selector (500/600 models) to select the desired delay time and press **start**. The **delay time** icon will illuminate on the LED display to indicate the **delay time** option is activated. The time will begin counting down on the LED display once the washer **start/pause** button has been pressed.

# 30 CONTROLS AND SETTINGS

## Chime

A signal will sound at the end of each cycle (and periodically during **extended refresh**) if option is activated.

To mute or unmute the chime, press and **hold** the **select** button for **3 sec**.



## Other features LED display



*Icons may vary according to model.*

The estimated total cycle time will be displayed when the cycle is selected. The time may increase if water pressure is low, oversudsing occurs or the load becomes unbalanced. The approximate time remaining will be displayed during the cycle. **The eco, control lock, close door, mute (some models),** and delay time will also appear on this LED display.

## Eco indicator

The **eco** symbol will light up on the LED display to indicate that the selected combination of temperature, spin speed and options are eco friendly.

## Oversuds protection

A situation where oversudsing has been detected by the washer will result in the washer requiring additional rinses until the suds have been cleared. Each extra rinse the washer performs to clear the suds will add approximately 5 minutes to the cycle duration. The LED will display "SU" followed by "dS" and then the remaining cycle time (0 min) for 60 seconds and then repeat. Press

**cancel** to turn off the alert message. The washer will continue to perform rinse cycles until suds are removed.

## Reversed Hose Detection

If condition is detected where the inlet hoses have been installed incorrectly (hot supply to cold inlet and cold supply to hot inlet), the washer will alert you. The LED will display "HO" followed by "SE" and then the remaining cycle time (0 min) for 60 seconds and then repeat. Acknowledge the reversed hose condition by pressing the cancel button. Shut off each water supply valve and attach each supply hose to the correct inlet connection on the washer.



## Drum light (on select models)

The drum light will come on whenever the door is opened to illuminate the drum during loading and unloading. Closing the door turns off the light. The drum light will automatically turn off if the door is left open more than 3 minutes.

## Reversible door (on select models)

Your washer may be equipped with a reversible door. The door can be hinged on the right or left side.



## Trapped item detection

If an item is detected to be trapped between the door and the door gasket, the washer will pause the cycle and play an alert chime. The LED will display a loop of "CLEAR door" as shown below until the cancel button is pressed. Press the cancel button to unlock the door and remove the trapped item, then close the door and restart the cycle.

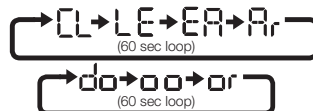

### Door stand ventilation

Help prevent odor buildup and reduce humidity between washes by utilizing your washer's door stand ventilation feature. Open the door, locate the stand below the door latch and rotate the stand counter-clockwise to unlock it.

#### NOTE

If unable to rotate the stand by hand, a coin or flat blade screw driver can be used.

The stand is spring loaded and will extend. Rotate it clockwise to lock in the extended position.

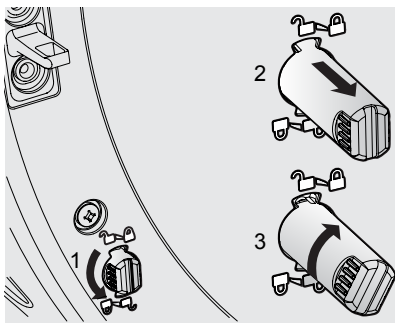

To disengage the stand, rotate to unlock, push the stand in and rotate to lock position.

#### NOTE

If door stand will not turn to locked position, fully turn it to unlock position and try to lock again.

# 32 OPERATING INSTRUCTIONS

## Operating the washer



### WARNING

To reduce the risk of fire, electric shock or injury to persons, read the **Important Safety Instructions** in this *Use & Care Manual* before operating your washer.



### WARNING

#### RISK OF INJURY



**DO NOT** wash water resistant and water repellent clothing or other materials. Failure to follow these instructions may result in an abnormal vibrating and out-of-balance condition that could result in physical injury, property damage, and/or appliance damage.



### CAUTION

#### ENTRAPMENT and TIP-OVER HAZARD

**DO NOT** leave the door open if there are small children or pets present. An open door could entice children to hang on the door or crawl inside the washer. If there are no small children present, you may leave the door ajar to prevent odor build up.

STEPS	TIPS	IMPORTANT
<p>1. Sort laundry into loads that can be washed together.</p> 	<ul style="list-style-type: none"> <li>Sort by recommended cycle and water temperature.</li> <li>Separate white, light, and colorfast items from dark and non-colorfast items.</li> <li>Separate items that shed lint from items that attract lint. Casual, synthetic, knit, and corduroy items will pick up lint from towels, rugs, and bedspreads.</li> <li>Separate heavily soiled items from lightly soiled items.</li> <li>Separate lacy, sheer, loosely knit, or delicate items from durable items.</li> </ul>	<p><b>DO NOT</b> machine wash items containing fiberglass. Small particles of fiberglass left in drum may transfer to fabrics in other loads and cause skin irritation and/or damage to fabrics.</p> <p><b>DO NOT</b> wash water resistant and water repellent type clothing or other materials</p>
<p>2. Prepare items for washing.</p> 	<ul style="list-style-type: none"> <li>Empty pockets.</li> <li>Brush off lint and dirt. Shake out rugs and beach towels.</li> <li>Close zippers, fasten hooks, button buttons, and tie strings/sashes. Remove non-washable trims and ornaments.</li> <li>Place delicate and small items (bras, hosiery, etc.) in a mesh bag (not included).</li> </ul>	<p>Mend rips and tears to prevent further damage during washing.</p> <p>Turn knit items inside out to prevent pilling.</p>
<p>3. Pretreat stains and heavy soil.</p>	<p>See stain treatment function in <i>Cycle Options</i> for your particular model or <i>Stain Removal Guide</i> for more information.</p>	
<p>4. Add laundry load to wash tub.</p>	<ul style="list-style-type: none"> <li>Combine large and small items in a load. Load large items first.</li> <li>Large items should not be more than half the total wash load.</li> <li>Washing single items is inefficient and may cause an out-of-balance load. Add 1 or 2 similar items to help balance load.</li> <li>Wash single heavy items (comforter, sleeping bag, etc.) separately.</li> <li>The washer can be fully loaded, but the items should not be tightly packed. The door should close easily.</li> </ul>	<p><b>DO NOT</b> overload the washer.</p> <p><b>DO NOT WASH:</b> Water resistant and water repellent clothing or other materials.</p>

STEPS	TIPS	IMPORTANT
<p>1. Add wash products to dispenser.</p>	<ul style="list-style-type: none"> <li>• Water conditioners, detergent boosters and enzyme products may be added with detergent</li> <li>• See <i>Adding Laundry Products</i> for detailed information on the use of the product dispensers.</li> <li>• See <i>Adding Laundry Products</i> for detailed information on the use of various wash products (detergent, bleach, stain treatment, fabric softener, etc).</li> </ul>	<p>Follow manufacturer's instructions and recommendations when using wash products.</p> <p>Open and close the dispenser drawer slowly. Closing the drawer too quickly could result in early dispensing of the bleach or fabric softener.</p>
<p>2. Select the cycle and settings for the load.</p>	<ul style="list-style-type: none"> <li>• See <i>Cycle Selection, Cycle Settings, and Cycle Options</i> for detailed descriptions of cycle controls.</li> <li>• See <i>Cycle Setting Charts</i> to determine which settings are available for each cycle.</li> <li>• To provide the best care, not every setting or option is available with every cycle. If a setting or option is not available for the cycle selected, the indicator will not light</li> </ul>	<p>Follow fabric care label instructions on items to be washed.</p> <p>Make sure that the PODS<sup>®</sup> option is selected when using models that have a separate detergent pack compartment. See <i>Adding Laundry Detergent to the Adaptive Dispenser™</i></p>
<p>3. Start the washer.</p>	<ul style="list-style-type: none"> <li>• Close the door and press start/pause. The washer will not operate with the door open. "CLOSE DOOR" will be displayed as a reminder to close the door.</li> <li>• To add a forgotten item to the washer any time during the wash portion of the cycle, press start/pause. When the door unlocks, open the door, add the item, close the door and press start/pause to resume cycle.</li> <li>• To change settings or options after the cycle has begun, press start/pause, change the settings, and then press start/pause. If the cycle is not paused first, the unit will emit several beeps when the buttons are pressed but no changes to the cycle will be applied.</li> <li>• To change the cycle once the cycle has begun, press cancel to cancel the cycle, select the new cycle, and press start/pause to begin the new cycle. Changing a cycle selection without cancelling the current WILL NOT change the cycle.</li> <li>• To cancel a cycle, press cancel.</li> <li>• A signal will sound at the end of the cycle if the chime option is not set to mute.</li> </ul>	<p><b>DO NOT</b> force door open. As a safety measure, the door will automatically lock during the entire wash cycle. Pause or cancel the wash load to unlock the door.</p> <p>If the cycle is interrupted during spin, the door lock will not release until the tub has stopped spinning.</p> <p>If the water level is above the bottom of the door opening/flexible door gasket, the lock will not release.</p>
<p>4. Remove items from washer when cycle has ended.</p>	<ul style="list-style-type: none"> <li>• Remove items when the cycle ends and place in dryer, line dry or dry flat as directed on the fabric care label.</li> </ul>	<p>Excess wrinkling, color transfer or odors may develop in items left in the washer after the cycle has ended.</p>

# 34 OPERATING INSTRUCTIONS

## Adding laundry products Laundry product dispensers

### Product dispenser - three compartment dispenser (300 Series)

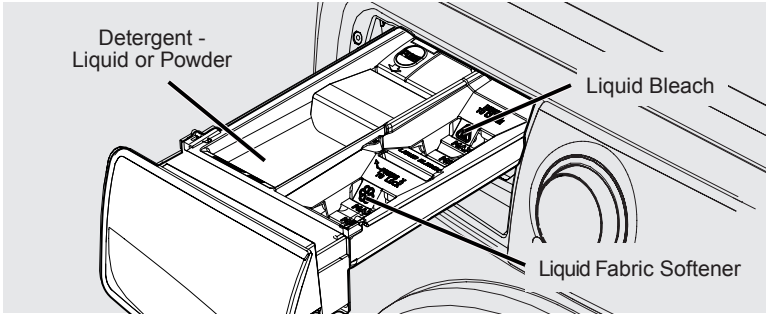

### Product dispenser - Adaptive Dispenser™ (400, 500, and 600 Series)

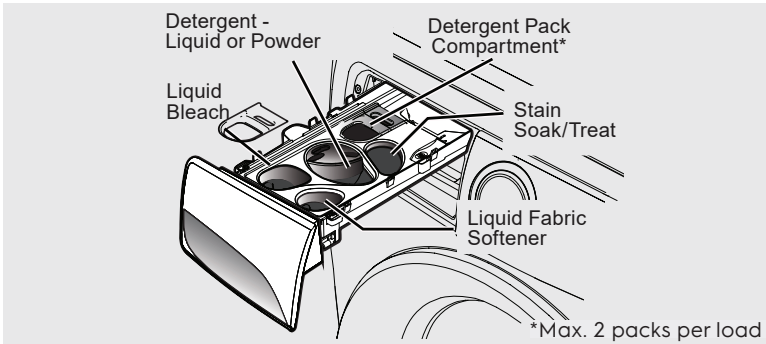

Detergent, stain treatment (on select models), liquid chlorine bleach and liquid fabric softener will be dispensed at the proper times in the cycle.

Use the cap or scoop provided by the detergent manufacturer to measure the amount recommended. Detergent dosage may need to be adjusted for water temperature, water hardness, load size and soil level.



### IMPORTANT

Open and close the dispenser drawer slowly. Closing the drawer too quickly could result in early dispensing of the bleach or fabric softener.

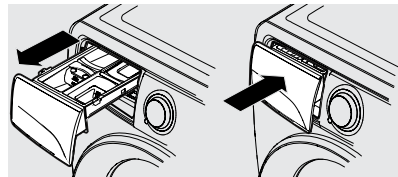

### For best results

Use a low-sudsing, high efficiency detergent to prevent oversudsing in front load washers. Look for this symbol on the detergent label: 

## Adding laundry detergent to the three compartment dispenser

### Liquid or powder detergent

- Use the cap or scoop provided by the detergent to add recommended amount of detergent
- Amount of detergent may need to be adjusted for water temperature, water hardness, load size, and soil level. Follow manufacturer's instruction.

In a three compartment dispenser use either liquid or powder detergent. **DO NOT** mix both.



### IMPORTANT

**DO NOT** mix liquids and powders.



### IMPORTANT

**DO NOT** exceed MAX fill line.

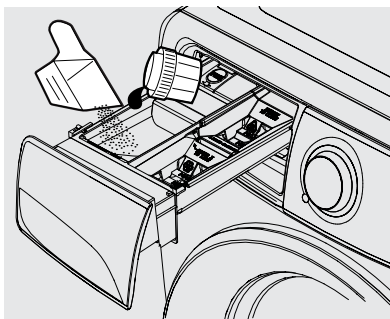

### IMPORTANT

**DO NOT** add detergent packs into the three compartment dispenser. Detergent packs should be added directly into the drum.



### CAUTION

Keep detergent packs away from children.

## Adding laundry detergent to the adaptive dispenser™

### Liquid detergent

- Use the cap or scoop provided by the detergent to add recommended amount of detergent to the detergent compartment. Pour directly into the detergent cup, not over the blue cover.
- Amount of detergent may need to be adjusted for water temperature, water hardness, and load size. Follow manufacturers instructions.

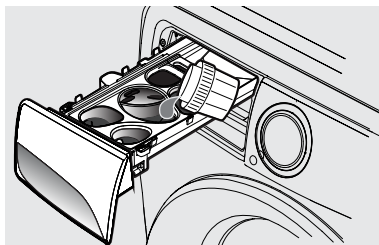

### IMPORTANT

Pour liquid into the liquid detergent cup. **DO NOT** pour over the blue cover. **DO NOT** exceed MAX fill line.

### Powder detergent

- Remove the liquid detergent cup and blue cover before adding powder detergent
- Add powder detergent directly to the powder detergent compartment.

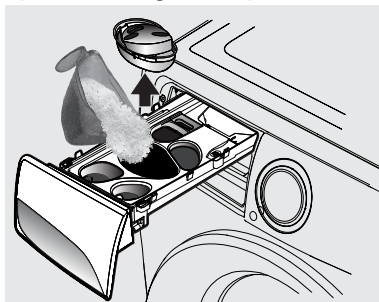

### IMPORTANT

Save the liquid detergent cup and blue cover for future use. **DO NOT** discard it while you are using powder detergent. **DO NOT** exceed MAX fill line.

# 36 OPERATING INSTRUCTIONS

## Detergent pack

### For 300 series models

Add detergent pack directly to the empty drum **BEFORE** placing laundry into the unit

- **DO NOT** place detergent packs directly into the detergent drawer. The gel coating may cause the detergent drawer to become clogged.

### For 400, 500 and 600 series models

Add the recommended quantity of high efficiency detergent packs to the detergent pack compartment in the dispenser.

- **DO NOT** place more than two packs into the dispenser.
- When using the **fast wash** cycle, only one detergent pack should be used.



## CAUTION

Keep detergent packs away from children.



## IMPORTANT

- When using the detergent pack compartment, make sure to select the **PODS<sup>®</sup>** option before starting the load.
- Once the **PODS<sup>®</sup>** option has been chosen, the washer will retain the **PODS<sup>®</sup>** setting until manually changed.
- The washer will **ALWAYS** use a small amount of **HOT** water to dissolve the pack when the **PODS<sup>®</sup>** option has been selected.

PODS<sup>®</sup>

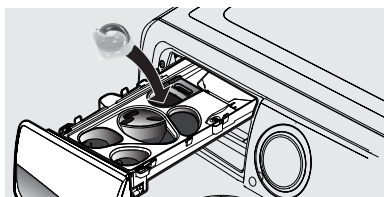

## NOTE

From time to time you may see water in the **dispenser**. This is part of the normal operation of the washer.

## Adding other wash products

- Color-safe bleach, water conditioner, detergent booster and enzyme products may be added with detergent.

- Put liquid products in the **Main Wash - liquid detergent** compartment or powder products in the **Main Wash - powder detergent** compartment.



## IMPORTANT

DO NOT mix liquids and powders.

## Stain treatment (on select models)

- For heavily soiled or stained loads, select the Stain option (on select models only - StainTreat, StainTreatII, or StainSoak) and add the recommended amount of detergent or stain treatment to stain soak/ treat compartment (on select models).
- See *Cycle Options* for information about Stain options for your model.
- See *Stain Removal Guide* in this instruction for additional suggestions.



## IMPORTANT

Use of multi-product (detergent plus softener) sheets or color-absorbing sheets **NOT** recommended. They could disable your machine and result in unwarranted repair costs.

## Liquid chlorine bleach

- If desired, add liquid chlorine bleach to the compartment labeled **Liquid Bleach** and marked with this symbol: .
- **DO NOT** fill above the **MAX** fill line.
- Add color-safe bleach with detergent.



## IMPORTANT

To prevent fabric damage, **DO NOT** overfill the **Liquid Bleach** compartment or pour bleach directly onto the load.

## Liquid fabric softener

- If desired, pour the recommended amount of liquid fabric softener into the compartment labeled **Fabric Softener** and marked with this symbol: .
- **DO NOT** fill above the **MAX** fill line.



## NOTE

To prevent staining, **DO NOT** overfill **Fabric Softener** compartment or pour liquid fabric softener directly on wash load.

- Use of a fabric softener-dispensing ball is not recommended in front load washers.



## Normal operating sounds

You may or may not hear the following sounds from your new washer:

- A. **DRAIN HOSE** The washer has a flexible drain hose to carry water from the washer to the stand pipe of your home. You will hear water flowing into your stand pipe. This is a normal part of the operation of the washer.
- B. **WATER VALVES/DISPENSER** As water enters the dispenser system, it is common to hear a water flowing sound. This normal sound will vary slightly based on the water pressure in your home.
- C. **DOOR LOCK** Your washer is equipped with a door lock with an electric solenoid. There will be a clicking sound as the washer door is being locked or unlocked.
- D. **DRAIN/RECIRCULATION PUMPS** Your washer is equipped with multiple high velocity system pumps. It is normal to hear humming and gurgling sounds as water is either pumped from the washer during the drain phase or recirculated during the prewash and wash phases. Both of these sounds are normal and indicate that your pump is functioning correctly.
- E. **HIGH SPEED MOTOR** A powerful motor is used to drive the drum to high spin speeds to extract water from your load. You will hear a sound associated with these higher spin speeds. This sound is normal and will vary slightly as the spin speed varies with load size and cycle selected.

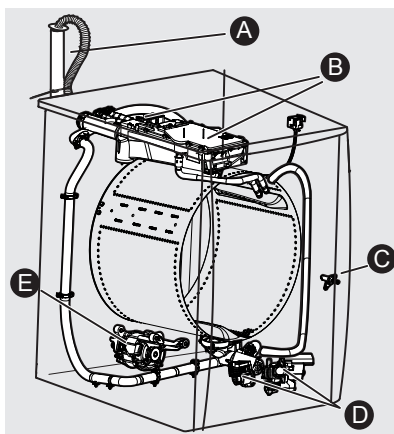

### CAUTION

Abnormal, on-going sounds may be an indication of a pending washer failure and should be investigated by a qualified technician. Refer to *NOISE* section of the Troubleshooting section of this manual.

# 38 STAIN REMOVAL GUIDE

## Stain removal procedures

To reduce the risk of fire or serious injury to persons or property, comply with the basic warnings listed below:

- Read and comply with all instructions on stain removal products.
- Keep stain removal products in their original labeled containers and out of children's reach.
- Thoroughly wash any utensils used.
- DO NOT combine stain removal products, especially ammonia and chlorine bleach. Dangerous fumes can result.
- Never wash items which have been previously cleaned in, washed in, soaked in or spotted with gasoline, dry cleaning solvents or other flammable or explosive substances because they give off vapors that could ignite or explode.
- Never use highly flammable solvents, such as gasoline, inside the home. Vapors can explode on contact with flames or sparks.

## For successful stain removal:

- Remove stains promptly.
- Determine the kind of stain, then follow the recommended treatment in the stain removal chart on the next page.
- To pretreat stains, use a stain treatment product, liquid detergent, or a paste made from powder detergent and water.
- Use cold water on unknown stains as hot water can set stains.
- Consult care label instructions for treatments to avoid on specific fabrics.
- Check for colorfastness by testing stain remover products on an inside seam.
- Rinse and wash items after stain removal.



## WARNING

### HARMFUL VAPOR HAZARD

DO NOT use or mix liquid chlorine bleach with other household chemicals such as toilet cleaners, rust removers, acids such as vinegar, or products containing ammonia. These mixtures can produce dangerous fumes which can cause serious injury or death.



## For best results

Follow the fabric care label instructions on items to be washed.



## Stain removal suggestions

STAIN	TREATMENT
Adhesive tape, gum, rubber cement	Apply ice. Scrape off excess. Place stain down on paper towels. Saturate with prewash stain remover or nonflammable dry cleaning fluid.
Baby formula, dairy products, egg	Use product containing enzymes to pretreat or soak stains. Soak for 30 minutes or more. Wash.
Beverages (coffee, tea, soda, juice, alcoholic beverages)	Pretreat stain. Wash using cold water and bleach safe for fabric.
Blood	Rinse with cold water. Rub with bar soap. Or, pretreat or soak with product containing enzymes. Wash using bleach safe for fabric.
Candle wax, crayon	Scrape off surface wax. Place stain face down between paper towels. Press with warm iron until wax is absorbed. Replace paper towels frequently. Treat remaining stain with prewash stain remover or nonflammable dry cleaning fluid. Hand wash to remove solvent. Wash using bleach safe for fabric.
Chocolate	Pretreat or soak in warm water using product containing enzymes. Wash using bleach safe for fabric.
Collar or cuff soil, cosmetics	Pretreat with prewash stain remover or rub with bar soap.
Dye transfer on white fabric	Use packaged color remover. Wash using bleach safe for fabric.
Grass	Pretreat or soak in warm water using product containing enzymes. Wash using bleach safe for fabric.
Grease, oil, tar (butter, fats, salad dressing, cooking oils, car grease, motor oils)	Scrape residue from fabric. Pretreat. Wash using hottest water safe for fabric. For heavy stains and tar, apply nonflammable dry cleaning fluid to back of stain. Replace towels under stain frequently. Rinse thoroughly. Wash using hottest water safe for fabric.
Ink	Some inks may be impossible to remove. Washing may set some inks. Use prewash stain remover, denatured alcohol or nonflammable dry cleaning fluid.
Mildew, scorch	Wash with chlorine bleach if safe for fabric or soak in oxygen bleach and hot water before washing. Badly mildewed fabrics may be permanently damaged.
Mud	Brush off dry mud. Pretreat or soak with product containing enzymes.
Mustard, tomato	Pretreat with prewash stain remover. Wash using bleach safe for fabric.
Nail polish	May be impossible to remove. Place stain face down on paper towels. Apply nail polish remover to back of stain. Repeat, replacing paper towels frequently. DO NOT use on acetate fabrics.
Paint, varnish	WATER BASED: Rinse fabric in cool water while stain is wet. Wash. Once paint is dry, it can't be removed. OIL BASED AND VARNISH: Use solvent recommended on label. Rinse thoroughly before washing.
Perspiration	Use prewash stain remover or rub with bar soap. Rinse. Wash using non chlorine bleach in hottest water safe for fabric.
Rust, brown or yellow discoloration	Use rust remover safe for fabric. DO NOT use chlorine bleach because it may intensify discoloration.
Shoe polish	LIQUID: Pretreat with a paste of powder detergent and water. PASTE: Scrape residue from fabric. Pretreat with prewash stain remover or nonflammable dry cleaning fluid. Rinse. Rub detergent into dampened area. Wash using bleach safe for fabric.
Tomato	Pretreat with prewash stain remover. Wash using fabric safe bleach.
Urine, vomit, mucus, feces	Pretreat or soak in product containing enzymes. Wash using bleach safe for fabric.
Wine	Pretreat or soak in cold water. Wash in hottest water and bleach safe for fabric.

# 40 CARE AND CLEANING

## Inside routine cleaning (preventative)

To help prevent odors or humidity accumulation leave the door open with the door stand ventilation feature (on select models) for a few hours after use or whenever the washer is not in use.



### CAUTION

#### ENTRAPMENT and TIP-OVER HAZARD

DO NOT leave the door open if there are small children or pets present. An open door could entice children to hang on the door or crawl inside the washer. If there are no small children present, you may leave the door ajar to prevent odor build up.

## To refresh or clean inside of washer

To clean and freshen the washer, perform the **clean washer** cycle. For best results perform the cycle once a month.



### NOTE

Every 50 cycles, your washer will remind you to perform the clean washer cycle by illuminating the clean washer cycle indicator.

To begin the cycle, select the **clean washer** cycle. If installed, remove the **LIQUID DETERGENT** cup from the dispenser. **REMOVE ALL ITEMS FROM WASH DRUM** before filling the detergent compartment with one (1) cup of liquid chlorine bleach OR one (1) pouch of Tide™ Washing Machine Cleaner. **DO NOT** use both. Press **start/pause** to begin.



### IMPORTANT

Items left in washer while performing the **clean washer** cycle will cause a severe out-of-balance situation that could damage the washing machine.



#### For best results

Immediately follow up with a rinse & spin cycle. Select max spin with no detergent or bleach to help clear any residual bleach left after the clean washer cycle.



### WARNING

#### HARMFUL VAPOR HAZARD

DO NOT use or mix liquid chlorine bleach with other household chemicals such as toilet cleaners, rust removers, acid or products containing ammonia. These mixtures can produce dangerous fumes which can cause serious injury or death.



## To Clean the dispenser drawer



### NOTE

Detergent and fabric softener may build up in the dispenser drawer. Residue should be removed once or twice a month.

## Cleaning the three compartment dispenser

1. Remove the drawer by pulling the drawer out until it stops.
2. Reach back into the left rear corner of the drawer cavity and press down firmly on the lock tab. Pull out the drawer.

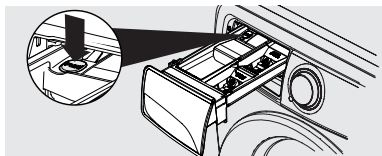

3. Remove all inserts from the drawers.

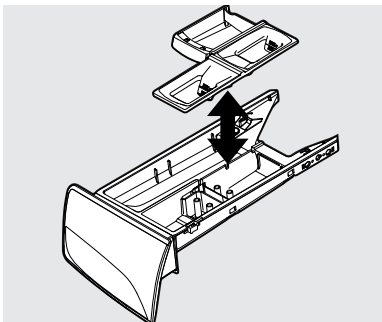

4. Rinse the drawer and inserts with hot tap water to remove traces of accumulated powders and liquids. Large amounts of fabric softener residue may indicate improper dilution or more frequent cleaning is required.
5. To clean the drawer opening, use a small brush to clean the recess. Remove all residue from the upper and lower parts of the recess.

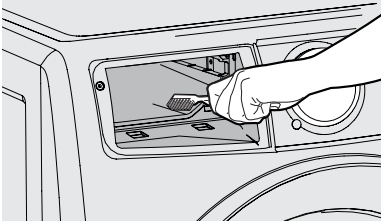

6. Replace the insert by pressing it in place until you hear a slight click.
7. Return the dispenser drawer to the unit

**Cleaning the Adaptive Dispenser™**

1. Remove the drawer by pulling the dispenser out until it stops.
2. Reach back into the right rear corner of the dispenser cavity and press down firmly on the lock tab. Pull out the dispenser drawer.

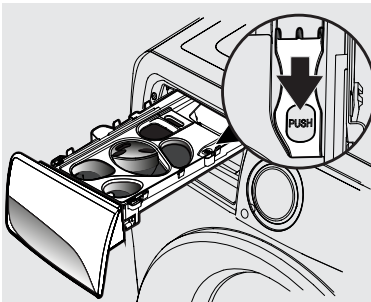

3. Remove the detergent cup and top cover from the dispenser drawer.
4. Remove the bottom cover from the dispenser drawer.
  - a) First, pull the two lock tabs at the rear of the dispenser drawer to unlatch the back cover.
  - b) Then, gently pull back the two clips on the front of the bottom cover to fully release it from the dispenser drawer.

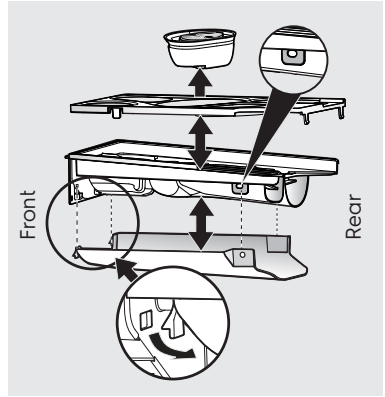

5. Rinse the dispenser drawer, covers, and detergent cup with hot tap water to remove traces of accumulated powders and liquids. Large amounts of fabric softener residue may indicate improper dilution or more frequent cleaning is required.
6. To clean the dispenser drawer opening, use a small brush to clean the recess. Remove all residue from the upper and lower parts of the recess.
7. Reassemble dispenser drawer and check to ensure that all pieces are securely in place.
8. Return the dispenser drawer to the unit

# 42 CARE AND CLEANING

## Inside cleaning (aggressive)

In cases where **clean washer** cycle along with care and cleaning of rubber gasket folds isn't done, and severe odor or residue buildup have developed, follow the below cleaning procedure to help alleviate the problem.

### Cleaning procedure-washer drum

Ensure the wash tub is empty. Open the detergent drawer and pour eight cups of bleach into the **Main Wash** detergent compartment. Select clean washer cycle as described previously in Inside Routine Cleaning (Preventative).

Upon cycle completion inspect the interior of the washer to see if the odor/residue has been eliminated. If any additional cleaning is required, repeat the above procedure. This may take several cycles depending on the severity of the odor/residue. You may observe some remaining discoloration due to the long term effects of this residue.

For especially contaminated areas visible inside the drum (including the front rubber seal), these areas might be more effectively cleaned by spraying a bleach cleaner on a scrub brush, soft sponge, or towel and scrubbing.



### IMPORTANT

Always wear rubber or latex gloves and protect floor and clothing from damage.

If odor is still left after bleach cycle(s) and bleach cleaner, open the detergent drawer and pour one (1) pouch of Tide™ Washing Machine Cleaner in detergent drawer. Select clean washer cycle as above and start the washer.



### For best results

Immediately follow up with a **rinse & spin** cycle. Select **max spin** with no detergent or bleach to help clear any residual bleach left after the **clean washer** cycle.



### IMPORTANT

See **Inside Routine Cleaning** for future cleaning maintenance which is necessary to avoid repeating issues.

### Three Compartment Preventative Cleaning

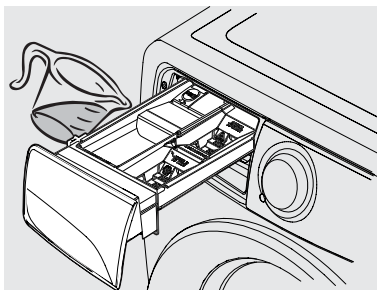

### Adaptive Dispenser™ Preventative Cleaning

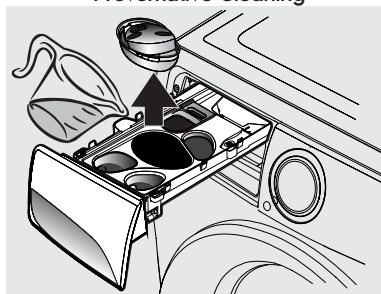

### WARNING

#### HARMFUL VAPOR HAZARD

DO NOT use or mix liquid chlorine bleach with other household chemicals such as toilet cleaners, rust removers, acid or products containing ammonia. These mixtures can produce dangerous fumes which can cause serious injury or death.



## Outside routine cleaning

- When washing is completed, wipe top and sides of washer with a damp cloth.
- Clean the cabinet with mild soap and water. Never use harsh, gritty or abrasive cleansers
- If the cabinet becomes stained, clean with diluted chlorine bleach (1 part bleach to 8 parts water). Rinse several times with clear water.
- Remove glue residue from tape or labels with a mixture of warm water and mild detergent. Or, touch residue with the sticky side of tape.
- When cleaning chrome parts, it is best to use only a damp cloth.
- Before moving the washer, place a strip of cardboard or thin fiberboard under the front leveling legs to prevent damage to the floor.



### IMPORTANT

DO NOT store or place laundry products on top of washer at any time. They can damage the finish or controls. It is recommended to keep laundry products in the storage drawer between cycles if installed on a pedestal.



## Winterizing instructions

1. Turn off water supply faucets.
2. Disconnect hoses from water supply and drain water from hoses. Vacuum out each water supply inlet with a waterproof utility vac to ensure water valves are completely drained. Damage will occur if water in water inlet valves are allowed to freeze.
3. Plug electrical cord into a properly grounded electrical outlet
4. Add 1 gallon (3.8 L) nontoxic recreational vehicle (RV) antifreeze to empty wash drum. Close door.
5. Select any cycle. Press **start/pause** and let the washer drain for 1 minute to drain out all the water. Not all of the RV antifreeze will be expelled.
6. Press **cancel**, unplug electrical power cord, dry off drum interior and close door.
7. Remove dispenser drawer. Drain any water in compartments and dry compartments. Replace drawer.
8. Store washer in an upright position.
9. To remove antifreeze from washer after storage, run empty washer through a complete cycle using detergent. DO NOT add wash load.



### IMPORTANT

If the washer is stored in an area where freezing can occur or moved in freezing temperatures, follow these winterizing instructions to prevent damage to the washer:



Follow WINTERIZING INSTRUCTIONS for cold weather storage and care.



# 44 CARE AND CLEANING

## Water inlet hose inspection

Periodically inspect all water inlet hoses for water leaks, wear, cuts, corrosion and bulges. Replace all hoses, if any sign of the above is visible. All hoses should be replaced every 5 years to reduce the risk of hose failures. When replacing hoses, refer to the Installation sections of this Use & Care Manual for proper installation instructions. DO NOT overtighten or cross thread the fittings. DO NOT allow the hose to rub against sharp objects. Always ensure the hose fitting rubber gasket is installed and free from water leaks when water pressure is applied.

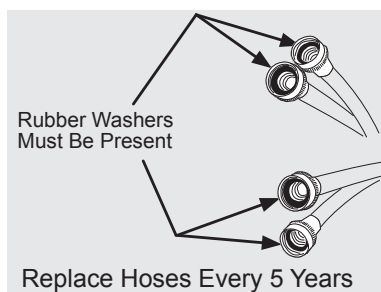

## Instructions for limited use, vacation and away from home



### CAUTION

Your washer should be operated **ONLY** when you are home. Water leakage is a safety issue and can cause personal injury or property damage. If you are away from home or not using your washer for extended periods of time, follow these steps:

1. Turn off the water supply to washer to avoid water leaks due to water pressure surges and unforeseen occurrences in the water supply.
2. Disconnect or unplug the electrical power to the washer.
3. Remove excess water from the dispenser, interior door and tub and perform the Care and Cleaning steps.

## Reconnecting water supply and electrical



### IMPORTANT

When reinstalling the washer after disconnecting the water supply lines and electrical power, please follow the steps below:

1. Review the *Installation* section of this manual to ensure the appliance is level and the water and electrical power supply is properly connected.
2. Ensure the water lines are flushed of debris, prior to connecting the water lines to the washer inlet.
3. Check for water leaks and replace supply hoses if needed.



### CAUTION

Damaged or improperly installed water lines can cause the water lines or connections to leak. Water leakage is a safety issue and can cause personal injury or property damage.



### WARNING

Improper grounding of the washer may cause serious injury or death. Check with a licensed electrician if you are in doubt as to whether the appliance is properly grounded.

Grounding type wall receptacle



Do not, under any circumstances, cut, remove, or bypass the grounding prong.

Power cord with 3-prong grounded plug



## Common washing inquiries

Many washing problems involve poor soil and stain removal, residues of lint and scum, and fabric damage. For satisfactory washing results, follow these suggestions provided by The Soap and Detergent Association.

PROBLEM	POSSIBLE CAUSES	SOLUTIONS	PREVENTIVE MEASURES
Blue stains	<ul style="list-style-type: none"> <li>• Undiluted liquid detergent or fabric softener dispensed directly onto fabric.</li> </ul>	<ul style="list-style-type: none"> <li>• If caused by detergent, mix 1 cup (240 ml) white vinegar with 1 qt (.95 L) water in plastic container. Soak 1 hour. Rinse.</li> <li>• If caused by fabric softener, rub stains with bar soap. Wash.</li> </ul>	<ul style="list-style-type: none"> <li>• Avoid overfilling detergent and fabric softener compartments of dispenser.</li> </ul>
Discoloration, graying	<ul style="list-style-type: none"> <li>• Not enough detergent</li> <li>• Wash water temperature too low.</li> <li>• Incorrect sorting.</li> </ul>	<ul style="list-style-type: none"> <li>• Rewash with correct amount of detergent and hottest water safe for fabric.</li> <li>• Add bleach safe for fabric.</li> </ul>	<ul style="list-style-type: none"> <li>• Sort items by soil level and color.</li> <li>• Use correct amount of detergent, hottest water and bleach safe for fabric.</li> </ul>
Greasy, oily stains	<ul style="list-style-type: none"> <li>• Not enough detergent</li> <li>• Undiluted liquid fabric softener poured directly on fabric.</li> </ul>	<ul style="list-style-type: none"> <li>• Treat with prewash stain remover or liquid detergent</li> <li>• Increase detergent and water temperature. Rewash.</li> <li>• Rub fabric softener stains with bar soap.</li> </ul>	<ul style="list-style-type: none"> <li>• Use correct amount of detergent and hottest water safe for fabric.</li> <li>• DO NOT pour liquid fabric softener directly on fabric.</li> </ul>
Holes, tears, or snags	<ul style="list-style-type: none"> <li>• Incorrect use of chlorine bleach.</li> <li>• Unfastened zippers, hooks, buckles.</li> <li>• Rips, tears and broken threads.</li> <li>• Overloading washer.</li> <li>• Degradation of fabric.</li> </ul>	<ul style="list-style-type: none"> <li>• May be irreversible if rips, tears and seams cannot be mended.</li> </ul>	<ul style="list-style-type: none"> <li>• Never pour chlorine bleach directly on fabric.</li> <li>• Check condition of items before washing.</li> </ul>
Lint	<ul style="list-style-type: none"> <li>• Incorrect sorting.</li> <li>• Tissues left in pocket</li> <li>• Overloading washer.</li> <li>• Not enough detergent</li> <li>• Undissolved detergent has left a residue resembling lint</li> <li>• Static cling is attracting lint</li> <li>• Load washed too long.</li> </ul>	<ul style="list-style-type: none"> <li>• Reduce load size. Rewash using correct water temperature, water level, and amount of detergent</li> <li>• Add nonprecipitating water conditioner to wash water to remove detergent residue.</li> <li>• Add liquid fabric softener to final rinse.</li> <li>• Dry load in dryer.</li> <li>• Remove lint with lint brush or roller.</li> </ul>	<ul style="list-style-type: none"> <li>• See <i>Operating Your Washer</i>.</li> <li>• DO NOT overload washer.</li> <li>• Use correct temperature and amount of detergent, water and wash time.</li> </ul>

# 46 TROUBLESHOOTING

PROBLEM	POSSIBLE CAUSES	SOLUTIONS	PREVENTIVE MEASURES
Pilling (Fibers ball up and cling to fabric.)	<ul style="list-style-type: none"> <li>Pilling is normal with synthetic and permanent press fabrics. This is due to abrasion from normal wear.</li> </ul>	<ul style="list-style-type: none"> <li>Use a lint brush or shaver to remove pills.</li> </ul>	<ul style="list-style-type: none"> <li>Use fabric softener in washer to lubricate fibers.</li> <li>When ironing, use spray starch or fabric finish on collars and cuffs.</li> <li>Turn items inside out to reduce abrasion.</li> </ul>
Residue or powder on dark items; Stiff, harsh fabrics.	<ul style="list-style-type: none"> <li>Undissolved detergent.</li> <li>Some granular detergents can combine with hard water minerals to form a residue.</li> <li>Overloading washer.</li> </ul>	<ul style="list-style-type: none"> <li>Rewash load.</li> </ul>	<ul style="list-style-type: none"> <li>Increase water temperature using hottest water safe for fabric.</li> <li>DO NOT overload washer.</li> <li>Use liquid detergent or nonprecipitating water conditioner with powder detergent.</li> </ul>
Wrinkling	<ul style="list-style-type: none"> <li>Overloading washer.</li> <li>Incorrect wash cycle for wash load.</li> </ul>	<ul style="list-style-type: none"> <li>Reduce load size.</li> <li>Rinse in cold water with liquid fabric softener using the casual or delicate cycle.</li> </ul>	<ul style="list-style-type: none"> <li>DO NOT overload washer.</li> <li>Remove items from washer as soon as cycle is completed.</li> <li>Use liquid fabric softener.</li> </ul>
Yellow buildup of body soil on synthetic fabrics	<ul style="list-style-type: none"> <li>Agitation time too short</li> <li>Wash water temperature too low.</li> <li>Not enough detergent</li> </ul>	<ul style="list-style-type: none"> <li>Soak in detergent booster or product containing enzymes.</li> <li>Wash in hottest water safe for fabric using casual cycle.</li> <li>Increase detergent</li> <li>Add bleach safe for fabric or treat with color remover.</li> </ul>	<ul style="list-style-type: none"> <li>Select correct cycle.</li> <li>Use correct amount of detergent</li> <li>Wash synthetics frequently using hot or warm water.</li> </ul>
Yellow or brown rust stains	<ul style="list-style-type: none"> <li>Iron or manganese in water supply, water pipes, or water heater.</li> </ul>	<ul style="list-style-type: none"> <li>To restore discolored load of whites, use rust remover safe for fabric.</li> <li>DO NOT use chlorine bleach to remove rust stains. It may intensify discoloration.</li> </ul>	<ul style="list-style-type: none"> <li>Use nonprecipitating water softener.</li> <li>Before washing, run hot water for a few minutes to clear lines.</li> <li>Drain water heater occasionally.</li> <li>For an ongoing problem, install an iron filter in your water supply system.</li> </ul>

PROBLEM	POSSIBLE CAUSES	SOLUTIONS	PREVENTIVE MEASURES
Residue stain buildup in gasket	<ul style="list-style-type: none"> <li>Moisture in washer.</li> <li>Use of non-HE detergent.</li> <li>Overdosing detergent.</li> <li>Overloading wash drum.</li> <li>Leaving a wet load set in washer.</li> <li>Cold water washes which may not completely dissolve and remove detergents.</li> </ul>	<ul style="list-style-type: none"> <li>Perform clean washer cycle</li> <li>Scrub gasket with Comet™ Spray Gel Mildew Stain Remover - use brush to remove stains.</li> <li>Use only HE (high efficiency detergent) along with recommended dosage.</li> <li>Remove wash load immediately upon cycle completion.</li> </ul>	<ul style="list-style-type: none"> <li>Run dehumidifier in laundry room.</li> <li>Avoid overfilling detergent and fabric softener compartments of dispenser.</li> <li>Dry the inside of washer and gasket after every run.</li> </ul>
Residue stain buildup in dispenser drawer or detergent pack not dissolved.	<ul style="list-style-type: none"> <li>Moisture in the washer.</li> <li>Use of non-HE detergent.</li> <li>Overdosing detergent.</li> <li>Adding more than two detergent packs to detergent pack compartment</li> <li>PODS® option not selected when using detergent pack (on select models).</li> </ul>	<ul style="list-style-type: none"> <li>Remove and clean dispenser and inserts with combination of ¾ cup liquid chlorine bleach and one gallon hot water. Rinse well, and repeat if necessary. NOTE: Wear rubber of latex gloves. Protect floor and clothing from bleach damage.</li> <li>Use only HE (high efficiency detergent) along with recommended dosage.</li> </ul>	<ul style="list-style-type: none"> <li>Avoid overfilling detergent and fabric softener compartments of dispenser.</li> <li>Check that PODS® option is selected and detergent pack is placed in PODS® dispenser compartment when using detergent pack (on select models).</li> </ul>
Water in fold of flexible gasket	<ul style="list-style-type: none"> <li>Result of washing and part of normal operation.</li> </ul>	<ul style="list-style-type: none"> <li>At the end of each wash, dry inside of gasket fold with clean dry towel all around gasket.</li> </ul>	
Odor	<ul style="list-style-type: none"> <li>Moisture in the washer.</li> <li>Use of non-HE detergent.</li> <li>Overdosing detergent.</li> <li>Leaving a wet load remain in washer.</li> <li>Cold water washes which may not completely dissolve and remove detergents.</li> </ul>	<ul style="list-style-type: none"> <li>Perform clean washer cycle.</li> <li>At the end of each wash, dry inside of gasket fold with clean, dry towel all around gasket.</li> <li>Use only HE (high efficiency detergent) along with recommended dosage.</li> <li>Remove wash load immediately upon cycle completion.</li> <li>Pour one cup liquid chlorine bleach in standpipe; let remain a day and flush with water.</li> </ul>	<ul style="list-style-type: none"> <li>Utilize the door stand ventilation feature for a few hours after use or whenever washer is not in use.</li> </ul>

# 48 TROUBLESHOOTING

## Before calling

Before calling for service, review this list. It may save both time and expense. The list includes common occurrences that are not the result of defective workmanship or materials in this washer.

PROBLEM	POSSIBLE CAUSES	SOLUTIONS
NOISE (Please refer to <i>Normal Operating Sounds</i> )		
High pitch "jet engine" noise	<ul style="list-style-type: none"> <li>A certain amount of motor whine is normal during the spin cycle.</li> </ul>	
Rattling and clanking noise	<ul style="list-style-type: none"> <li>Foreign objects such as coins or safety pins may be in drum or pump.</li> <li>Belt buckles and metal fasteners are hitting wash drum.</li> </ul>	<ul style="list-style-type: none"> <li>Stop washer and check drum. If no objects are found, perform cycle with empty drum. If noise continues, item may be in pump. Call your authorized service technician.</li> <li>To prevent unnecessary noise and damage to drum, fasten fasteners and turn items inside out.</li> </ul>
Thumping sound	<ul style="list-style-type: none"> <li>Heavy wash loads may produce a thumping sound. This is usually normal. If sound continues, washer is probably out of balance.</li> </ul>	<ul style="list-style-type: none"> <li>Stop washer and redistribute wash load.</li> </ul>
Vibrating noise	<ul style="list-style-type: none"> <li>Washer is not resting firmly on floor.</li> <li>Shipping bolts and foam block have not been removed during installation.</li> <li>Wash load unevenly distributed in drum.</li> </ul>	<ul style="list-style-type: none"> <li>Move washer so it rests firmly on floor. Adjust leveling legs. See <i>Leveling the washer</i> for details.</li> <li>See Installation sections of this manual for removing shipping bolts and foam block.</li> <li>Stop washer and rearrange wash load.</li> </ul>
OPERATING		
Residue left in drum	<ul style="list-style-type: none"> <li>Heavily soiled items.</li> </ul>	<ul style="list-style-type: none"> <li>Wipe drum with a nonabrasive household cleanser, then rinse. Shake or brush excess dirt and sand from items before washing.</li> </ul>
LED displays "dr"	<ul style="list-style-type: none"> <li>Washer has been programmed to temporarily perform a repeating demo cycle.</li> </ul>	<ul style="list-style-type: none"> <li>Reset the unit back to factory default settings.               <ol style="list-style-type: none"> <li>Press power to turn off unit. Press power again to turn unit on. Look for console to light up.</li> <li>Wait at least 10 seconds, then simultaneously press and hold soil and options buttons for 3 secs.</li> <li>Lights will turn OFF and ON, indicating the unit has been reset to factory default</li> </ol> </li> </ul>
Washer won't spin	<ul style="list-style-type: none"> <li>Load is too small.</li> </ul>	<ul style="list-style-type: none"> <li>Add 1 or 2 similar items to help balance the load.</li> </ul>
LED Displays "CLEAR door"	<ul style="list-style-type: none"> <li>Washer has detected something trapped between the door and door gasket.</li> </ul>	<ul style="list-style-type: none"> <li>Press the cancel button to unlock the door, remove the trapped item, close the door and restart the cycle.</li> </ul>

PROBLEM	POSSIBLE CAUSES	SOLUTIONS
Washer does not start	<ul style="list-style-type: none"> <li>• Electrical power cord may not be plugged in or connection may be loose.</li> <li>• House fuse blown, circuit breaker tripped, or a power outage has occurred.</li>   <li>• Action of pressing start/pause button on “touch screen” style console not recognized.</li> <li>• Water supply faucets are not turned on.</li> <li>• Motor is overheated. Washer motor will stop if overheated.</li>   <li>• Door may be open. Unit will not operate with door open.</li> <li>• Light next to start/pause button is flashing indicating unit is paused.</li> </ul>	<ul style="list-style-type: none"> <li>• Make sure plug fits tightly in wall outlet.</li> <li>• Reset circuit breaker or replace fuse. DO NOT increase fuse capacity. If problem is a circuit overload, have it corrected by a qualified electrician. If problem is a power outage, call local electric company.</li> <li>• Press start/pause button with bare fingertip.</li> <li>• Turn on water supply faucets.</li> <li>• It will automatically restart after a cool down period of up to 30 minutes (if washer has not been manually turned off).</li> <li>• Ensure door is closed.</li> <li>• Press start/pause button to continue the cycle.</li> </ul>
<b>WATER</b>		
Water collects in folds of the door gasket at the end of the cycle	<ul style="list-style-type: none"> <li>• This is a result of the washing action and is part of the normal operation of the washer.</li> </ul>	<ul style="list-style-type: none"> <li>• Wipe and dry the gasket to remove water and any debris remaining in the gasket after use.</li> </ul>
Water collects in bleach and fabric softener compartments	<ul style="list-style-type: none"> <li>• This is a result of the siphoning action and is part of the normal operation of the washer.</li> </ul>	<ul style="list-style-type: none"> <li>• Water may be removed by removing the dispenser drawer (see <i>Care and Cleaning</i> in this manual) and draining water into the empty drum or sink.</li> </ul>
Wash load too wet after spin	<ul style="list-style-type: none"> <li>• Washer is overloaded.</li> <li>• Load is too small.</li> <li>• Load is out of balance.</li> <li>• Drain hose is kinked.</li> </ul>	<ul style="list-style-type: none"> <li>• DO NOT overload washer. See <i>Operating Your Washer</i>.</li> <li>• Add 1 or 2 similar items to help balance load.</li> <li>• Rearrange load to allow proper spinning.</li> <li>• Straighten drain hose.</li> </ul>
Water does not enter washer or it enters slowly	<ul style="list-style-type: none"> <li>• Water supply is not adequate in area.</li> <li>• Water supply faucets are not completely open.</li> <li>• Water is being used elsewhere in the house. Water pressure must be at least 30 psi (260 kPa).</li> <li>• Water inlet hoses are kinked.</li> <li>• Water inlet screens plugged.</li> </ul>	<ul style="list-style-type: none"> <li>• Check another faucet in the house. Wait until water supply and pressure increase.</li> <li>• Fully open hot and cold faucets.</li> <li>• Avoid running water elsewhere while washer is filling.</li> <li>• Straighten hoses.</li> <li>• Remove hose from inlets and clean screens.</li> </ul>

# 50 TROUBLESHOOTING

PROBLEM	POSSIBLE CAUSES	SOLUTIONS
Warm or hot water is not hot enough	<ul style="list-style-type: none"> <li>Hot water heater is set too low or is a distance from washer.</li> <li>Hot water is being used elsewhere in the house.</li> </ul>	<ul style="list-style-type: none"> <li>Measure hot water temperature at nearby faucet with candy or meat thermometer. Water temperature should be at least 120°F (49°C). Adjust water heater as necessary.</li> <li>Avoid using hot water elsewhere before or during washer use. There may not be enough hot water available for proper cleaning. If problem persists, your hot water system may be unable to support more than 1 use at a time.</li> </ul>
Water in washer does not drain or drains slowly	<ul style="list-style-type: none"> <li>Drain hose is kinked or clogged.</li> <li>Drain hose standpipe is too tall. Maximum standpipe height is 8' (2.4 m).</li> <li>House drain pipes are clogged.</li> </ul>	<ul style="list-style-type: none"> <li>Clean and straighten the drain hose.</li> <li>Reduce standpipe height to less than 8' (2.4 m). See Installation sections of this manual.</li> <li>Unclog drain pipes. Contact plumber if necessary.</li> </ul>
Water leaks	<ul style="list-style-type: none"> <li>Fill hose connection is loose at faucet or washer.</li> <li>Dispenser drawer not completely closed</li> <li>Water hoses have damage, cuts or corrosion.</li> </ul>	<ul style="list-style-type: none"> <li>Check and tighten hose connections. Install rubber sealing washers provided.</li> <li>Close dispenser drawer completely.</li> <li>Replace hoses.</li> </ul>
Oversudsing	<ul style="list-style-type: none"> <li>HE detergent is not being used.</li> <li>Too much detergent</li> </ul>	<ul style="list-style-type: none"> <li>Run rinse cycle. Use a low-sudsing, high efficiency detergent.</li> <li>Run rinse cycle. Use less detergent in future loads.</li> </ul>
Incorrect wash and rinse temperatures. The LED display will alert this condition with "HOSE" alarm	<ul style="list-style-type: none"> <li>Hot and cold water hoses are connected to wrong supply faucets.</li> </ul>	<ul style="list-style-type: none"> <li>Connect hot water hose to hot water faucet and cold water hose to cold water faucet</li> </ul>
Water is entering washer but tub does not fill	<ul style="list-style-type: none"> <li>Drain hose standpipe is too low. Standpipe must be a min of 23.6" (60 cm) high to prevent siphoning.</li> </ul>	<ul style="list-style-type: none"> <li>Increase standpipe height to at least 23.6" (60 cm). See Installation sections of this manual.</li> </ul>

For the applicable warranty period as set forth below, as measured from your original date of purchase, Electrolux will repair or replace any parts of this appliance that prove to be defective in materials or workmanship when such appliance is installed, used and maintained in accordance with the provided instructions.

#### Warranty Periods:

- All parts — One year including labor. In addition, your appliance is covered by a one year, parts only, limited warranty. During the 2nd year from your original date of purchase, Electrolux will pay for parts needed for this appliance that have proven to be defective in materials or workmanship when your appliance is installed, used, and maintained in accordance with the provided instructions.
- Inner wash tub (washer) — Functional life of the product (excluding labor)
- Wash tub drive motor (washer), non-cosmetic defects — Ten years (excluding labor)

#### Exclusions

This warranty does not cover the following:

1. Products with original serial numbers that have been removed, altered or cannot be readily determined.
2. Product that has been transferred from its original owner to another party or removed outside the USA or Canada.
3. Rust on the interior or exterior of the unit.
4. Products purchased "as-is" are not covered by this warranty.
5. Products used in a commercial setting.
6. Service calls which DO NOT involve malfunction or defects in materials or workmanship, or for appliances not in ordinary household use or used other than in accordance with the provided instructions.
7. Service calls to correct the installation of your appliance or to instruct you how to use your appliance.
8. Expenses for making the appliance accessible for servicing, such as removal of trim, cupboards, shelves, etc., which are not a part of the appliance when it is shipped from the factory.
9. Service calls to repair or replace appliance light bulbs, air filters, water filters, other consumables, or knobs, handles, or other cosmetic parts.
10. Pickup and delivery costs; your appliance is designed to be repaired in the home.
11. Surcharges including, but not limited to, any after hour, weekend, or holiday service calls, tolls, ferry trip charges, or mileage expense for service calls to remote areas, including the state of Alaska.
12. Damages to the finish of appliance or home incurred during transportation or installation, including but not limited to floors, cabinets, walls, etc.
13. Damages caused by: services performed by unauthorized service companies; use of parts other than genuine Electrolux parts or parts obtained from persons other than authorized service companies; or external causes such as abuse, misuse, inadequate power supply, accidents, fires, or acts of God.

#### DISCLAIMER OF IMPLIED WARRANTIES; LIMITATION OF REMEDIES

CUSTOMER'S SOLE AND EXCLUSIVE REMEDY UNDER THIS LIMITED WARRANTY SHALL BE REPAIR OR REPLACEMENT AS PROVIDED HEREIN. **CLAIMS BASED ON IMPLIED WARRANTIES, INCLUDING WARRANTIES OF MERCHANTABILITY OR FITNESS FOR A PARTICULAR PURPOSE, ARE LIMITED TO ONE YEAR OR THE SHORTEST PERIOD ALLOWED BY LAW, BUT NOT LESS THAN ONE YEAR.** ELECTROLUX SHALL NOT BE LIABLE FOR CONSEQUENTIAL OR INCIDENTAL DAMAGES SUCH AS PROPERTY DAMAGE AND INCIDENTAL EXPENSES RESULTING FROM ANY BREACH OF THIS WRITTEN LIMITED WARRANTY OR ANY IMPLIED WARRANTY. SOME STATES AND PROVINCES DO NOT ALLOW THE EXCLUSION OR LIMITATION OF INCIDENTAL OR CONSEQUENTIAL DAMAGES, OR LIMITATIONS ON THE DURATION OF IMPLIED WARRANTIES, SO THESE LIMITATIONS OR EXCLUSIONS MAY NOT APPLY TO YOU. THIS WRITTEN WARRANTY GIVES YOU SPECIFIC LEGAL RIGHTS. YOU MAY ALSO HAVE OTHER RIGHTS THAT VARY FROM STATE TO STATE.

#### If You Need Service

Keep your receipt, delivery slip, or some other appropriate payment record to establish the warranty period should service be required. If service is performed, it is in your best interest to obtain and keep all receipts. Service under this warranty must be obtained by contacting Electrolux at the addresses or phone numbers below.

This warranty only applies in the USA, Puerto Rico and Canada. In the USA and Puerto Rico, your appliance is warranted by Electrolux Major Appliances North America, a division of Electrolux Home Products, Inc. In Canada, your appliance is warranted by Electrolux Canada Corp. Electrolux authorizes no person to change or add to any obligations under this warranty. Obligations for service and parts under this warranty must be performed by Electrolux or an authorized service company. Product features or specifications as described or illustrated are subject to change without notice.

#### USA

1-877-435-3287

Electrolux Home Products, Inc.,  
North America  
10200 David Taylor Drive  
Charlotte, NC 28262



Electrolux

#### Canada

1-800-265-8352

Electrolux Canada Corp.  
5855 Terry Fox Way  
Mississauga, Ontario, Canada  
L5V 3E4

CE

A20448601 (March 2021)